

INTRODUCTION (1)

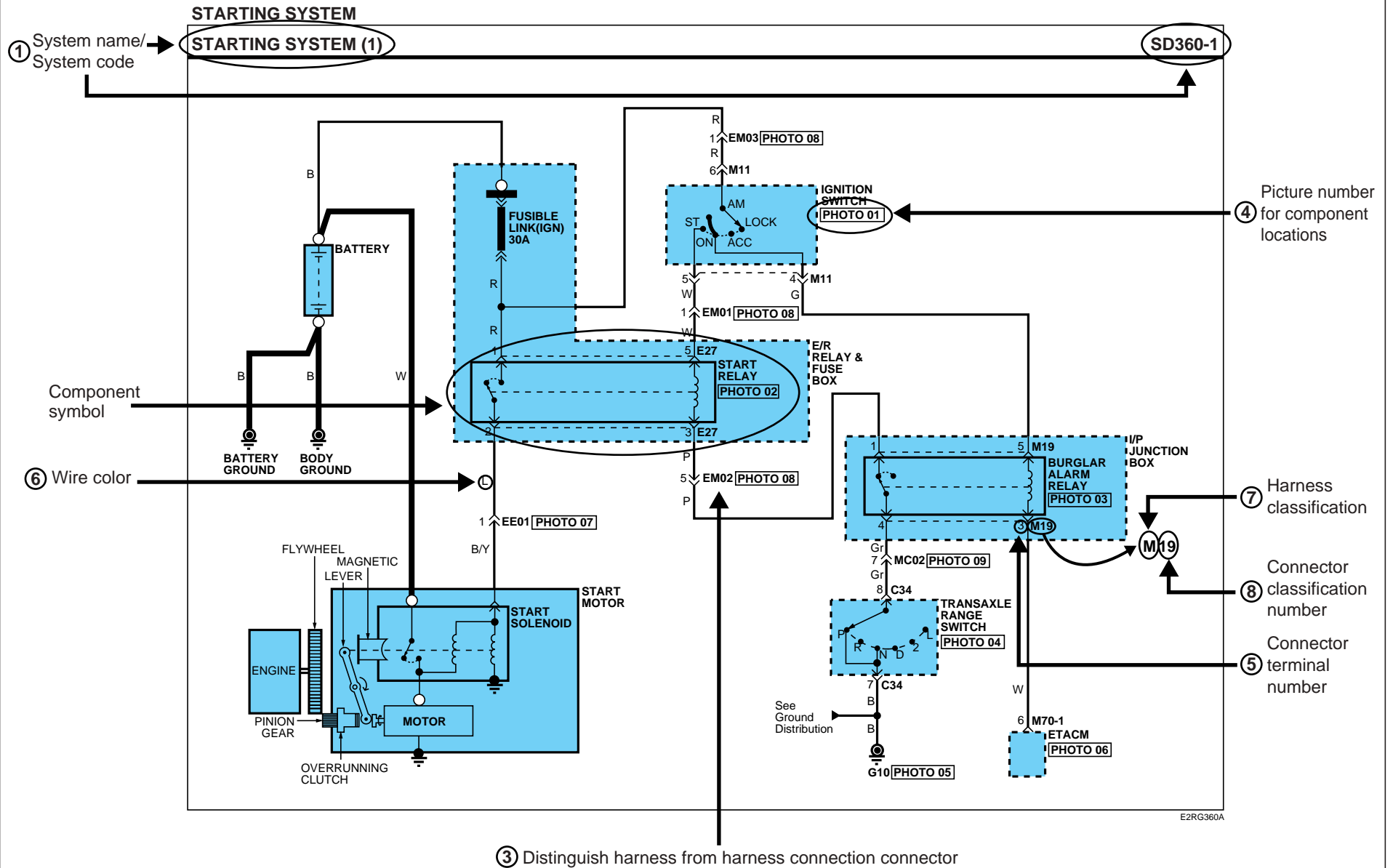

E2RG360A

INTRODUCTION

INTRODUCTION (2)

GI-2

STARTING SYSTEM

STARTING SYSTEM (2)

SD360-2

② Connector configurations (components)

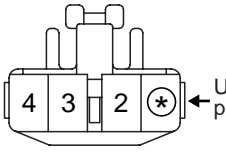
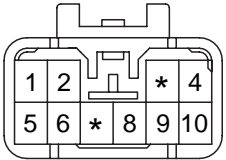
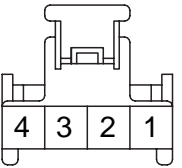
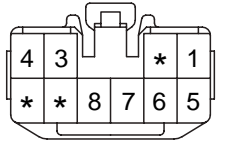
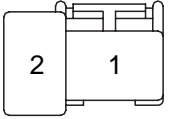
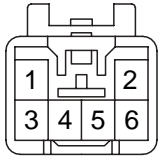
<p>M05</p>  <p>KET_090II_04F_W</p>	<p>M06</p>  <p>KET_090II_10M_W</p>	<p>M11</p>  <p>KUM_AR_04F_W</p>	<p>M13</p>  <p>KET_090II_10F_W</p>
<p>M67</p>  <p>AMP_PLM2_02F_B</p>	<p>M81</p>  <p>KET_090II_06M_W</p>	<p>BLANK</p>	<p>BLANK</p>

E2RG360B

Explanation of connector code

M05

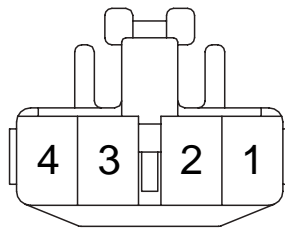

KET_090II_04F_W

a b c d e

a : Connector manufacturer

b : Terminal series number

c : The number of connector terminals

d : Connector distinguishing

- Female Pin : F
- Male Pin : M

e : Connector color abbreviations

- B (Black)
- Br (Brown)
- G (Green)
- Gr (Gray)
- L (Blue)
- R (Red)
- W (White)
- Y (Yellow)

① Pages by system/ Name of Schematic diagram

- Each page is consisted of circuits by system. This schematic diagram includes the path of electricity flow, connection condition for each switch, and the function of other relevant circuits at once. It is applicable to real service work.
- It is very important to understand relevant circuits exactly before troubleshooting diagnosis.
- Circuits by system depends upon part number and are indicated on schematic diagram index.

② Connector configuration (components)

- The connector figure of components in the schematic diagram by system is indicated on the last page of schematic diagram.
- It shows the front of the connector on the harness side when not to the harness connector. The terminal number on each connector can be obtained by following the pattern used in ⑤ connector view and numbering order. Unused terminals are marked with an asterisk (*).

③ Connector configurations (connection between harnesses)

- When connecting the harness with connector between harnesses, it shows female and male connectors and indicates them on the connector configurations group.

EM02

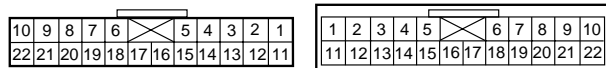

④ Component locations

- To find the components easily, a component locations diagram is indicated with "PHOTO NO" on the lower portion of the component name.
- To make it easy to distinguish connectors, the connector in the picture is indicated being installed in the vehicle.

PHOTO 03

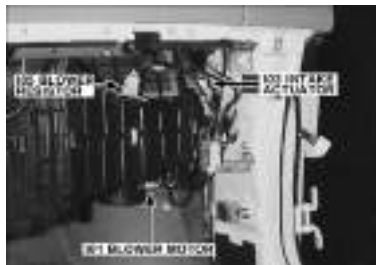

⑤ CONNECTOR VIEW AND NUMBERING ORDER

Female	Male	Remarks
		<p>It is not the shape of the connector housing, but the connector pin that distinguishes between male or female connectors. When numbering female and male connectors, refer to the numbering order in the following table. Some connectors may not follow this method of numbering order. For individual detailed numbering, refer to the CONNECTOR CONFIGURATIONS.</p>
		<p>Numbered in order from upper right to lower left</p> <p>Numbered in order from upper left to lower right</p>

NOTE

UNLESS OTHERWISE STATED, ALL CONNECTOR VIEWS ARE FROM THE TERMINAL SIDE OF THE CONNECTOR.

INTRODUCTION

INTRODUCTION (4)

GI-4

⑥ WIRE COLOR ABBREVIATIONS

The following abbreviations are used to identify wire colors in the circuit schematics.

Symbol	Color of wire	Symbol	Color of wire
B	Black	O	Orange
Br	Brown	P	Pink
G	Green	R	Red
Gr	Gray	W	White
L	Blue	Y	Yellow
Lg	Light Green	Pp	Purple
T	Tan	LI	Light Blue

* **(Y/B)**: Black stripe with yellow ground (2 colors)

↑ ↑
the color of the color of
background stripe

⑦ HARNESS CLASSIFICATION

Electrical wiring connectors are classified according to the wiring parts in the Harness Layouts.

Harness name	Location
Engine harness	Engine compartment
Main, Floor, Roof, Sunroof, Seat warmer ext. harness	Passenger compartment, Floor, Roof
Control, Injector harness	Engine compartment, Passenger compartment
Tail gate, Tail gate ext. harness	Tail gate
Air bag harness, A/C harness	Under crash pad and Floor
Door harness	Door

* It depends on vehicles, it is necessary to check the harness name symbol on the harness layouts for detailed symbol.

⑧ CONNECTOR IDENTIFICATION

A connector identification symbol consists of a wiring harness location classification symbol corresponding to a wiring harness location and number corresponding to the connector. These connector locations can be found in the HARNESS LAYOUTS.

For example:

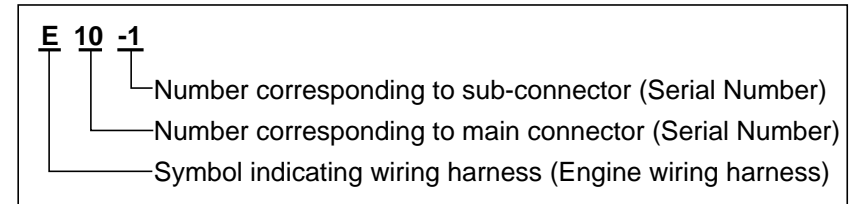

NOTE

Connectors which connect each wiring harness are represented by the following symbols.

For example:

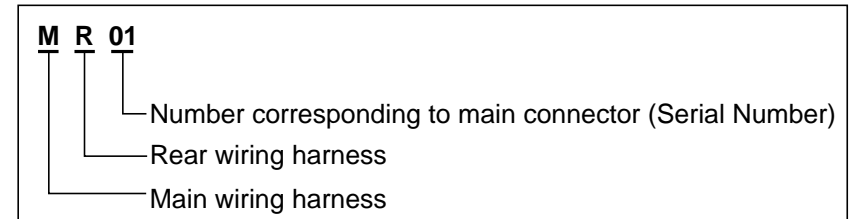

JUNCTION BLOCK IDENTIFICATION

A junction block identification symbol consists of a wiring harness location classification symbol corresponding to a wiring harness location and number corresponding to the connector in the junction block.

For example:

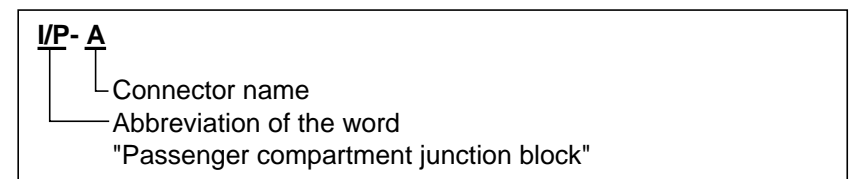

HARNESS LAYOUTS

Harness layouts show the routing of the major wiring harnesses, the in-line connectors and the splices between the major harnesses. These layouts will make electrical troubleshooting easier.

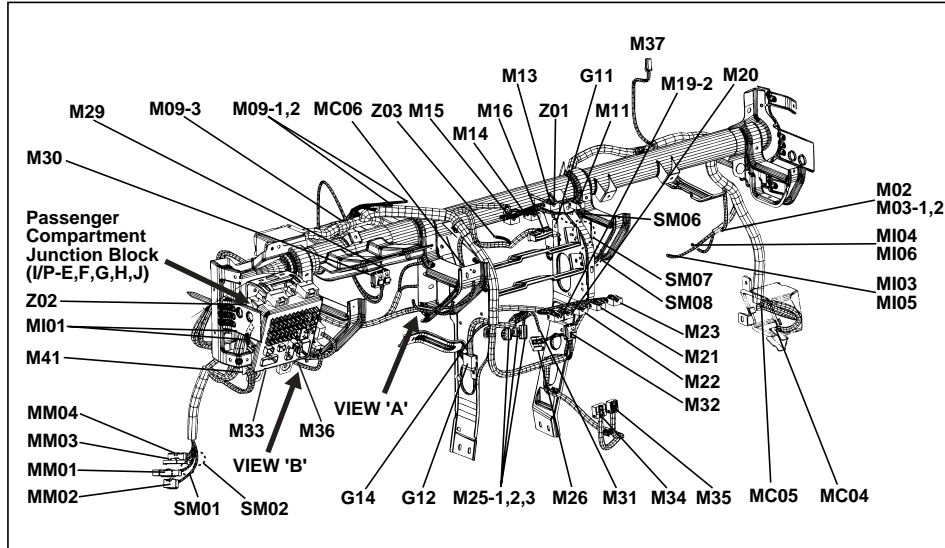









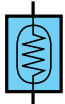
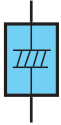

SYMBOLS (1)

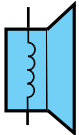
Section	Symbol	Meaning	Section	Symbol	Meaning	Section	Symbol	Meaning	Section	Symbol	Meaning
C O M P O N E N T		A solid line means the entire component is shown.	C O N N E C T O R		Shows the name of each connector on the component location index for reference.	S H I E L D W I R E		This represents RFI (Radio Frequency Interference) Shielding around a wire. The shielding is always connected to ground.	L A M P		Double filament
		A broken line indicates only part of the component is shown.			Indicates the number of corresponding terminal. (Only relevant terminal on the corresponding schematic diagram).			Single filament			
		This means the connector connects directly to the component.	W I R E		A wavy line means the wire is broken but is to be continued.	J O I N T C O N N E C T O R		This is a connector showing the joining wires.	D I O D E		Diode
		This indicates the connector connects to a lead (pigtail), wired directly to the component.			Wire insulation is yellow with a red strip.			Led diode			
		This indicates a screw terminal on the component.	S P L I C E S		Current path is continued on the same page or another page. The arrow shows the direction of current flow. You should look for the "A" in the marked position.	S L O W B L O W		Power supplied at all times. Name Capacity	T R		NPN
		This ground symbol (dot and 3 lines overlapping the component) means the housing of the component is attached to a metal part of the vehicle.			A wire connects to another circuit. The wire is shown again on that circuit which the arrow is pointing.			PNP			
		The name of the component appears next to its upper right corner.	G R O U N D		Name of Circuit	F U S E		This means power is supplied with the ignition on position. This means the short bar connects to other fuses. Identification Current rating	G E N E R A L C O M P O N E N T S Y M B O L		These switches move together: a dashed line shows a mechanical connection between them.
		Shows the number of pictures for component location.			Splices are numbered and shown as a dot with circle. The exact location and connection of these splices may vary among vehicles.			NOT IN ON DASH FUSE BOX FUSE 10 10A			Switch (1 contact point)
					This symbol means the end of the wire is attached to a metal part of the vehicle.						Heater

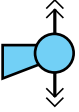
SYMBOLS

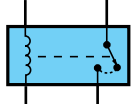
SYMBOLS (2)

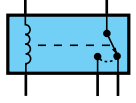
GI-7

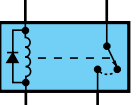
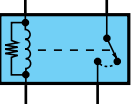
Section	Symbol	Meaning	Section	Symbol	Meaning
GENERAL COMPONENTS SYMBOL		Sensor	GENERAL COMPONENTS SYMBOL		Condenser
		Sender			Speaker
		Injector			Horn, Buzzer, Siren, Chime Bell
		Solenoid	RELAY		Normally open contact
		Motor			This is a relay shown with no current flowing through its coil. When a current flows through coil, contact will toggle.
		Battery			Diode interior relay
				Resistance interior relay	

TROUBLESHOOTING INSTRUCTIONS (1)

GI-8

TROUBLESHOOTING INSTRUCTIONS

TROUBLESHOOTING PROCEDURES

The following five-step troubleshooting procedure is recommended.

1. Verify the customer's complaints

Turn on all the components in the problem circuit to check the accuracy of the customer's complaints. Note the symptoms. Do not begin disassembly or testing until you have narrowed down the probable causes.

2. Read and analyze the schematic diagram

Locate the schematic for the problem circuit. Determine how the circuit is supposed to work by tracing the current paths from the power source through the system components to ground. If you do not understand how the circuit should work, read the circuit operation text. Also check other circuits that share with the problem circuit. The name of circuits that share the same fuse, ground, or switch, for example, are referred to on each diagram. Try to operate any shared circuits you did not check in step 1. If the shared circuit works, the shared wiring is okay, and the cause must be within the wiring used only by the problem circuit.

If several circuits fail at the same time, the fuse or ground is a likely cause.

3. Inspect the circuit/ component with the problem isolated

Make a circuit test to check the diagnosis you made in step 2. Remember that a logical, simple procedure is the key to efficient troubleshooting. Narrow down the probable causes using the troubleshooting hints and system diagnosis charts. Test for the most likely cause of failure first. Try to make tests at points that are easily accessible.

4. Repair the problem

Once the problem is found, make the necessary repairs.

5. Make sure the circuit works

Repeat the system check to be sure you have repaired the problem. If the problem was a blown fuse, be sure to test all of the circuits on that fuse.

TROUBLESHOOTING EQUIPMENT

VOLTMETER AND TEST LAMP

Use a test lamp or a voltmeter on circuits without solidstate units and use a test lamp to check for voltage. A test lamp is made up of a 12-volt light bulb with a pair of leads attached. After grounding one lead, touch the other lead to various points along the circuit where voltage should be present. When the bulb goes on, there is voltage at the point being tested.

CAUTION

A number of circuits include solid-state modules, such as the Engine Control Module(ECM), used with computer command control injection. Voltage in these circuits should be tested only with a 10-megaohm or higher impedance digital multimeter. Never use a test lamp on circuits that contain solid state modules. Damage to the modules may result.

A voltmeter can be used in place of a test lamp. While a test lamp shows whether the voltage is present or not, a voltmeter indicates how much voltage is present.

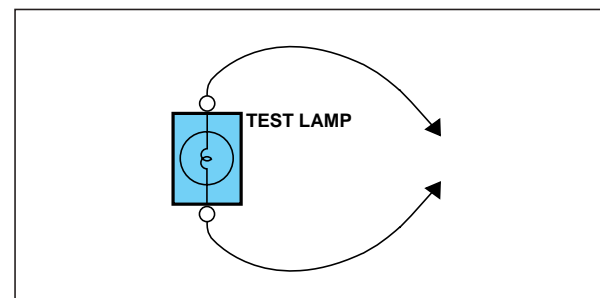
**SELF-POWERED TEST LAMP AND OHMMETER**

Use a self-powered test lamp or an ohmmeter to check for continuity. The ohmmeter shows how much resistance there is between two points along a circuit. Low resistance means good continuity.

TROUBLESHOOTING INSTRUCTIONS

TROUBLESHOOTING INSTRUCTIONS (2)

GI-9

CAUTION

Never use a self-powered test lamp on circuits that contain solid state modules. Damage to these modules may result.

An ohmmeter can be used in place of a self-powered test lamp. The ohmmeter shows how much resistance there is between two points along a circuit. Low resistance means good continuity.

Circuits which include any solid-state devices should be tested only with a 10-megaohm or higher impedance digital multimeter. When measuring resistance with a digital multimeter, the battery negative terminal should be disconnected. Otherwise, there may be incorrect readings. Diodes and solid-state devices in a circuit can make an ohmmeter give a false reading. To find out if a component is affecting a measurement, take one reading, reverse the leads and take a second reading. If different the solid-state device is affecting the measurement.

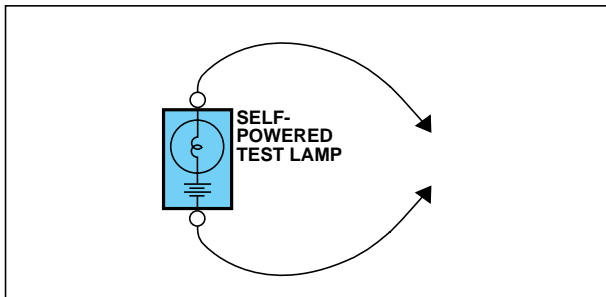

JUMPER WIRE WITH FUSE

Use a jumper wire with a fuse to by-pass an open circuit.

A jumper wire is made up of an in-line fuse holder connected to a set of test leads. This tool is available with small clamp connectors providing adaption to most connectors without damage.

CAUTION

Do not use a fuse with a higher rating than the specified fuse that protects the circuit being tested. Do not use this tool in any situation to substitute an input or output at the solid-state control module, such as ECM, TCM, etc.

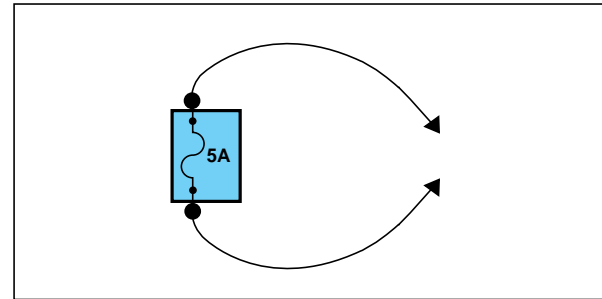

SHORT FINDER

A short finder is available to locate a short to ground. The short finder creates a pulsing magnetic field in the shorted circuit and shows you the location of the short through body trim or sheet metal.

TROUBLESHOOTING TEST

1. TESTING FOR VOLTAGE

This test measures voltage in a circuit. When testing for voltage at a connector, you do not have to separate the two halves of the connector. Instead, probe the connector from the back(backprobe). Always check both sides of the connector because dirt and corrosion between its contact surfaces can cause electrical problems.

- A. Connect one lead of a test lamp or voltmeter to a ground. If you are using a voltmeter, be sure it is the voltmeter's negative test lead you have connected to ground.
- B. Connect the other lead of the test lamp or voltmeter to a selected test point(connector or terminal).
- C. If the test lamp glows, there is voltage present. If you are using a voltmeter, note the voltage reading. A loss of more than 1 volt from specification indicates a problem.

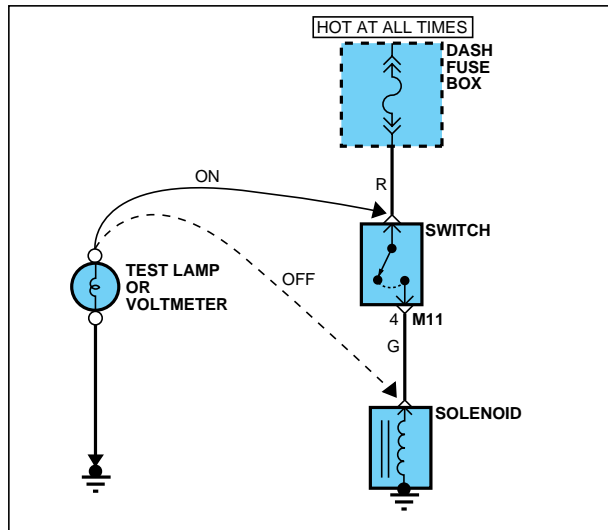

2. TESTING FOR CONTINUITY

- A. Disconnect the battery negative terminal.
- B. Connect one lead of a self-powered test lamp or ohmmeter to one end of the part of the circuit you wish to test. If you are using an ohmmeter, hold the leads together and adjust the ohmmeter to read zero ohms.
- C. Connect the other lead to the other end.
- D. If the self-power test lamp glows, there is continuity. If you are using an ohmmeter, low or zero resistance means good continuity.

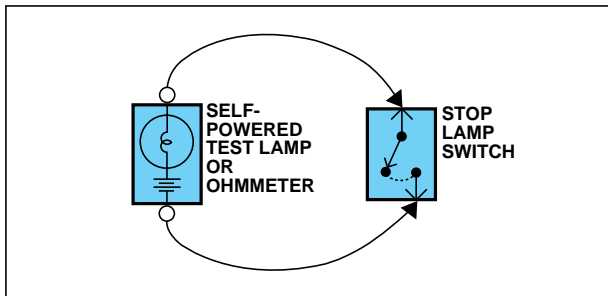

3. TESTING FOR SHORT TO GROUND

- A. Disconnect the battery negative terminal.
- B. Connect one lead of a self-powered test lamp or an ohmmeter to the fuse terminal on the load side.
- C. Connect the other lead to a ground.
- D. Beginning near the fuse block move the harness from side to side. Continue this procedure (about six inches apart) while watching the self-powered test lamp or ohmmeter.
- E. When the self-powered test lamp glows, or ohmmeter registers, there is a short to a ground in the wiring near that point.

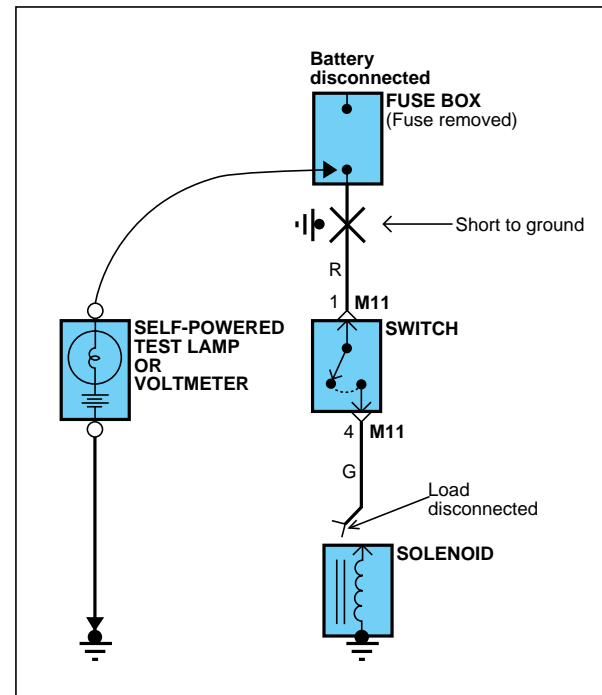

4. TESTING FOR A SHORT WITH A SHORT FINDER

- A. Remove the blown fuse. Leave the battery connected.
- B. Connect the short finder across the fuse terminals.
- C. Close all switches in series in the circuit that is being testing.
- D. Turn on the short circuit locator. It sends pulses of current to the short.
This creates a pulsing magnetic field around the wiring between the fuse box and the short.
- E. Beginning at the fuse box, slowly move the short finder along the circuit wiring. The meter will show current pulses through sheet metal and body trim. As long as the meter is between the fuse and the short, the needle will move with each current pulse. Once the meter is moved past the point of the short, the needle will stop moving. Check around this area to locate the cause of the short circuit.

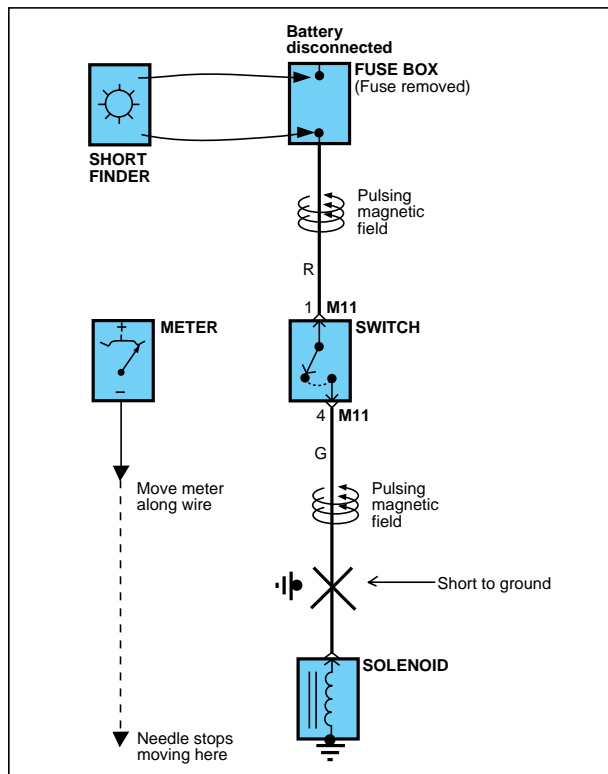

FUSE & RELAY INFORMATION (1)

SD100-1

I/P JUNCTION BOX

< FRONT >

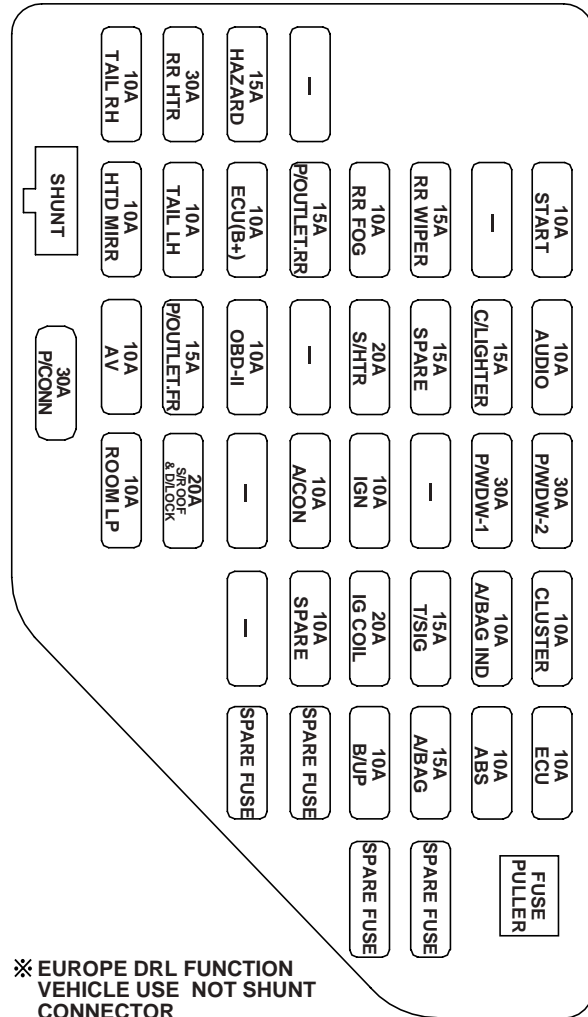

※ EUROPE DRL FUNCTION
VEHICLE USE NOT SHUNT
CONNECTOR

(LHD)

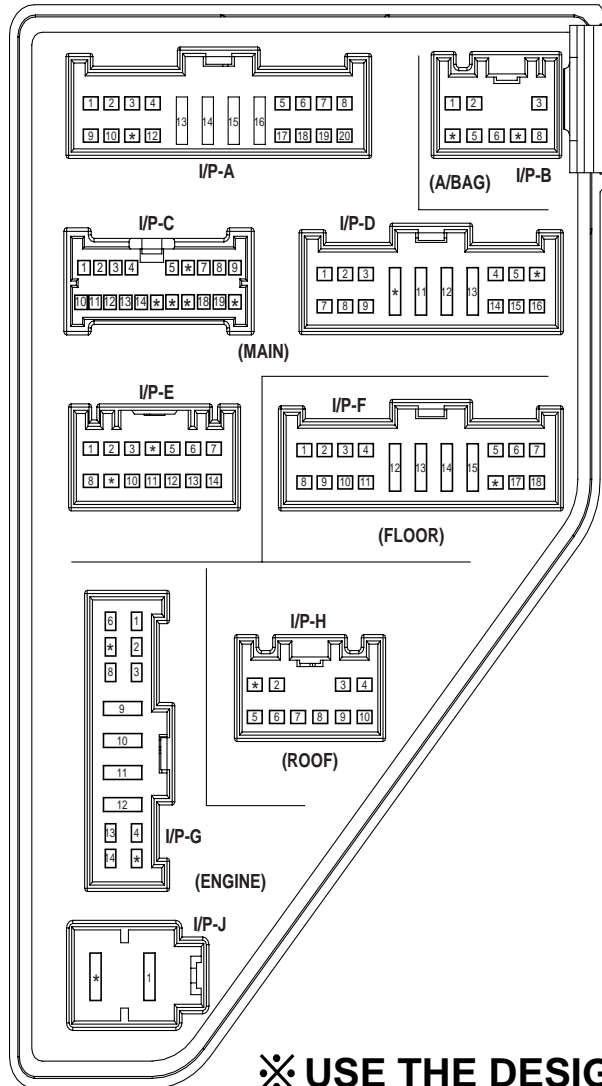

< REAR >

(RHD)

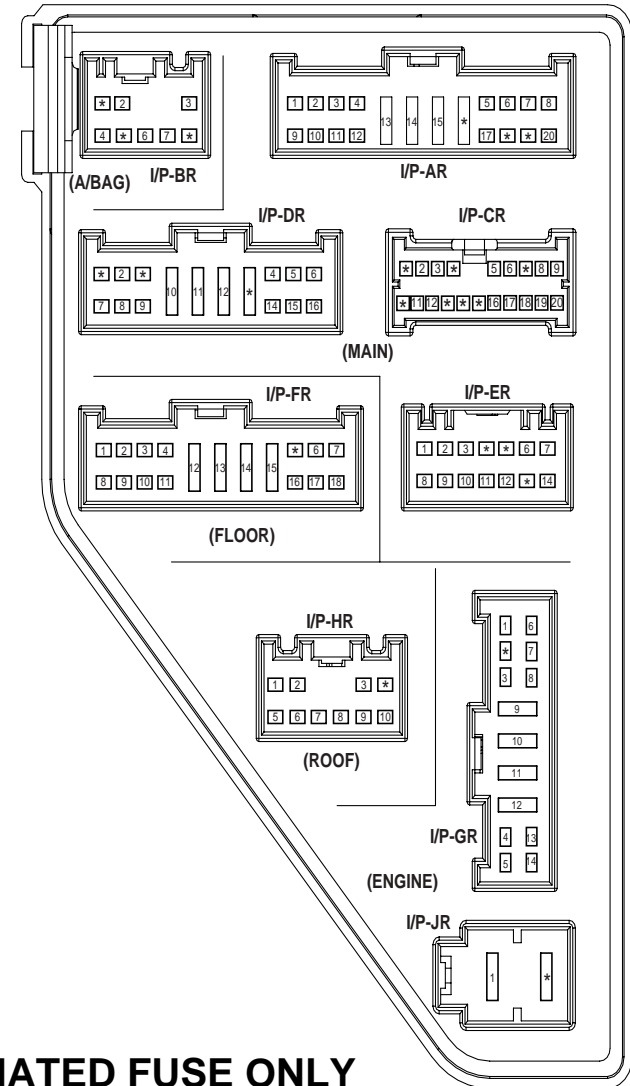

※ USE THE DESIGNATED FUSE ONLY

FUSE & RELAY INFORMATION

FUSE & RELAY INFORMATION (2)

SD100-2

CIRCUIT

FUSE	(A)	Circuit Protected
TAIL RH	10A	Rear Combi Lamp RH, Head Lamp RH, Front Fog Lamp Relay, DRL Control Module, Illuminations
RR HTR	30A	Rear Defogger Relay, Contact, Fuse(HTD MIRR)
HAZARD	15A	Hazard Relay, Hazard Switch, ETACM, Instrument Cluster Multifunction Switch, Rear Combi Lamp LH/RH, Head Lamp LH/RH, Side Repeater Lamp LH/RH,
HTD MIRR	15A	Power Outside Mirror Motor LH/RH, A/C Control Module
TAIL LH	10A	Head Lamp LH, Rear Combi Lamp LH, License Lamp LH/RH
ECU(B+)	10A	TCM, Immobilizer Control Module
P/OUTLET. RR	15A	Rear Power Outlet
RR FOG	10A	Rear Fog Lamp Relay
RR WIPER	15A	Instrument Cluster, ETACM, Luggage Lamp, Cargo Lamp, Tailgate Switch, Rear Window Switch, Rear Wiper Relay, Multifunction Switch, Rear Defogger Relay, Safety Relay
START	10A	Burglar Alarm Relay, Cruise Control Module, Start Relay Transaxle Range Switch
AV	10A	Audio
P/OUTLET. FR	15A	Front Power Outlet
OBD-II	10A	Data Link Connector, Multipurpose Check Connector
S/HTR	20A	Seat Warmer Switch
C/LIGHTER	15A	Cigarette Lighter
AUDIO	10A	Power Outside Mirror Switch, Digital Clock Audio

FUSE	(A)	Circuit Protected
ROOM LP	10A	Key Remind Switch, Instrument Cluster, ETACM, Room Lamp A/C Control Module, Digital Clock, Luggage Lamp, Front Door Lamp, Map Lamp, Cargo Lamp, Sunroof Switch
S/ROOF & D/LOCK	20A	Door Lock / Unlock Relay, Sunroof Controller
A/CON	10A	A/C Control Module, ETACM, Blower Relay, Sunroof Controller Electro Chrome Mirror & Compass
IGN	10A	Head Lamp Relay, AQS Sensor, DRL Control Module, Fuel Filter Heater Relay
P/WDW -1	30A	Driver Power Window Switch Rear Power Window Switch LH
P/WDW -2	30A	Passenger Power Window Switch Rear Power Window Switch RH
IG COIL	20A	Ignition Coil(2.7 GSL)
T/SIG	15A	Hazard Switch, Auto Light & Photo Sensor
A/BAG IND	10A	Instrument Cluster
CLUSTER	10A	Instrument Cluster, ETACM, Immobilizer Control Module Pre-excitation Resistor, Alternator, DRL Control Module
B/UP	10A	Back-up Lamp Switch, Transaxle Range Switch
A/BAG	15A	SRS Control Module
ABS	10A	ABS Control Module, ESP Control Module, G-sensor, TCS Switch, ESP Switch, Steering Angle Sensor
ECU	10A	Immobilizer Control Module, Vehicle Speed Sensor, ECM, TCM Pulse Generator 'A/B', Fuel Filter Warning Switch, Cruise Control Module, Mass Air Flow Sensor, 4WD ECM, Stop Lamp Switch, Multifunction Switch

✘ USE THE DESIGNATED FUSE ONLY

FUSE & RELAY INFORMATION

FUSE & RELAY INFORMATION (3)

SD100-3

E/R JUNCTION BOX LAYOUT

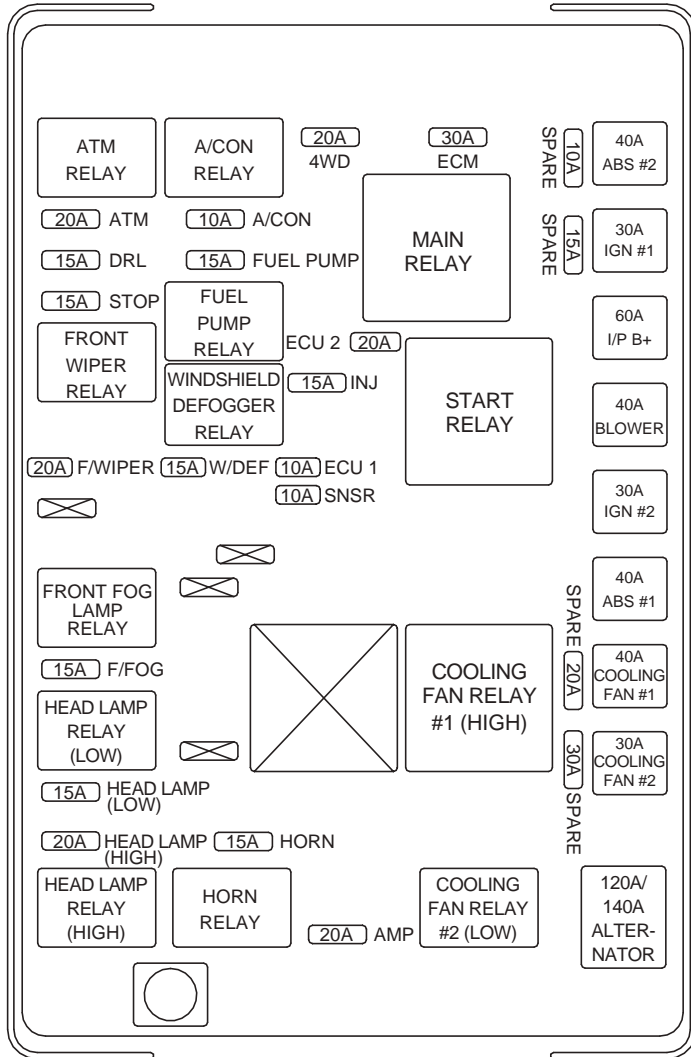

CIRCUIT

FUSE	(A)	Circuit Protected
ALTERNATOR	120A/140A	Battery, Alternator
I/P B+	60A	I/P Junction Box
BLOWER	40A	Blower Relay
ABS #1	40A	ABS Control Module, ESP Control Module
ABS #2	40A	ABS Control Module, ESP Control Module
COOLING FAN #1	40A	Cooling Fan Relay #1 (HIGH)
COOLING FAN #2	30A	Cooling Fan Relay #2 (LOW)
IGN #1	30A	Ignition Switch (IG1, ACC)
IGN #2	30A	Ignition Switch (IG2, START), Start Relay
ECM	30A	Main Relay, Fuel Pump Relay, SNSR 10A, INJ 10A, ECM, ECU 1 10A, ECU 2 20A
4WD	20A	4WD ECM
F/WIPER	20A	Front Wiper Relay, Front Wiper motor, Multifunction Switch
AMP	20A	Sub Woofer, AMP #1
HEAD LAMP (HIGH)	20A	Head Lamp Relay (HIGH)
ATM	20A	ATM Relay
FUEL PUMP	15A	Fuel Pump Relay
INJ	15A	ECM, Injector, Stop Lamp Switch, EGR Actuator, ISA, CCV Throttle Flap Actuator, Variable Intake Manifold Control Motor #1/#2
STOP	15A	Stop Lamp Switch
W/DEF	15A	Windshield Defogger Relay
F/FOG	15A	Front Fog Lamp Relay
HEAD LAMP (LOW)	15A	Head Lamp Relay (LOW)
HORN	15A	Horn Relay, Alternator, Burglar Horn Relay
A/CON	10A	A/CON Relay
SNSR	10A	MAF Sensor, PTC HTR Relay, Glow Plug Relay, Oxygen Sensor, ECM, SMATRA Crankshaft Position Sensor
DRL	15A	DRL Control Module
ECU 1	10A	ECM (DSL EURO-IV)
ECU 2	20A	ECM (DSL EURO-IV)

✳ USE THE DESIGNATED FUSE ONLY

FUSE & RELAY INFORMATION

FUSE & RELAY INFORMATION (4)

SD100-4

DIESEL BOX

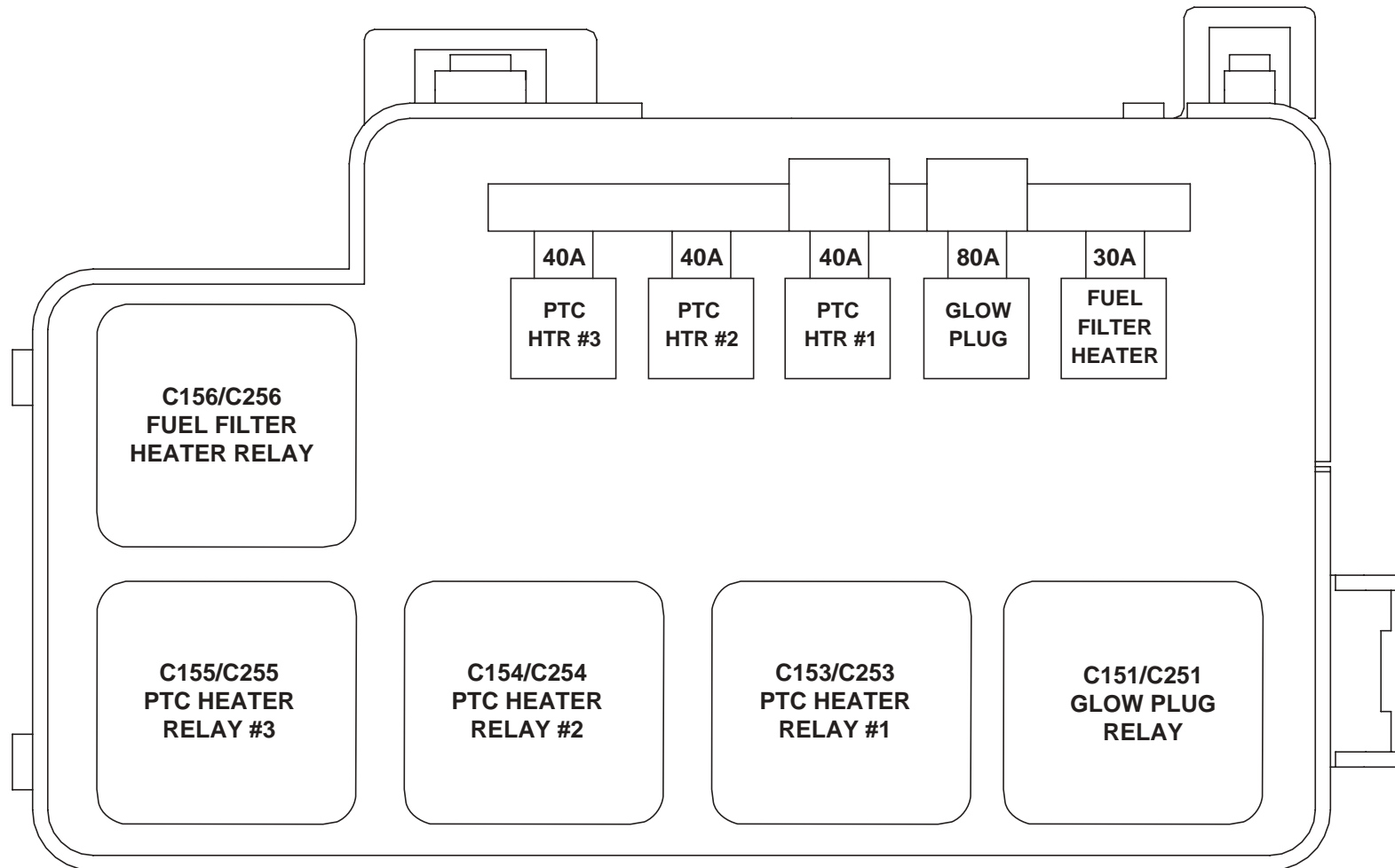

⌘ USE THE DESIGNATED FUSE ONLY

POWER DISTRIBUTION (1)

SD110-1

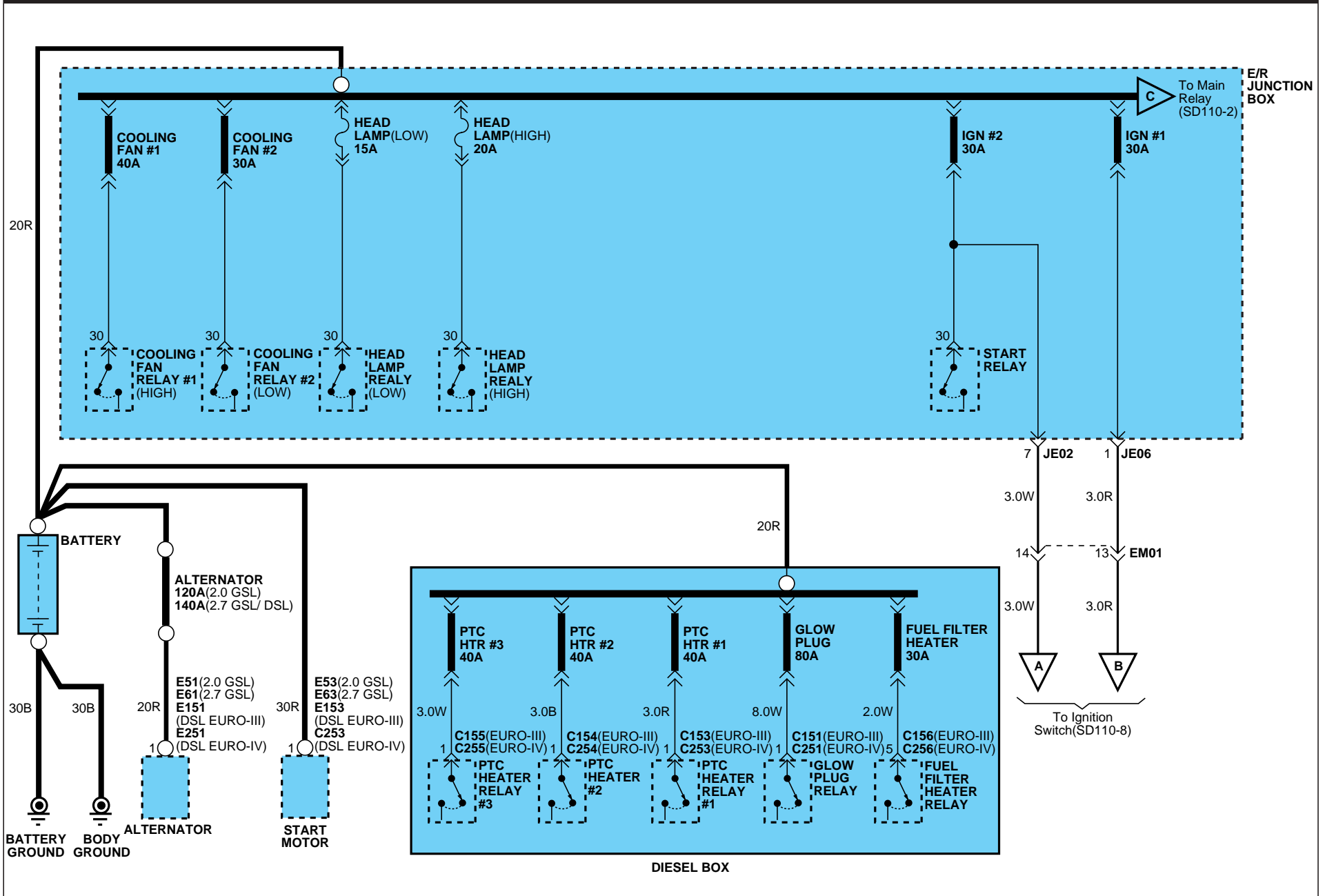

POWER DISTRIBUTION

POWER DISTRIBUTION (2)

SD110-2

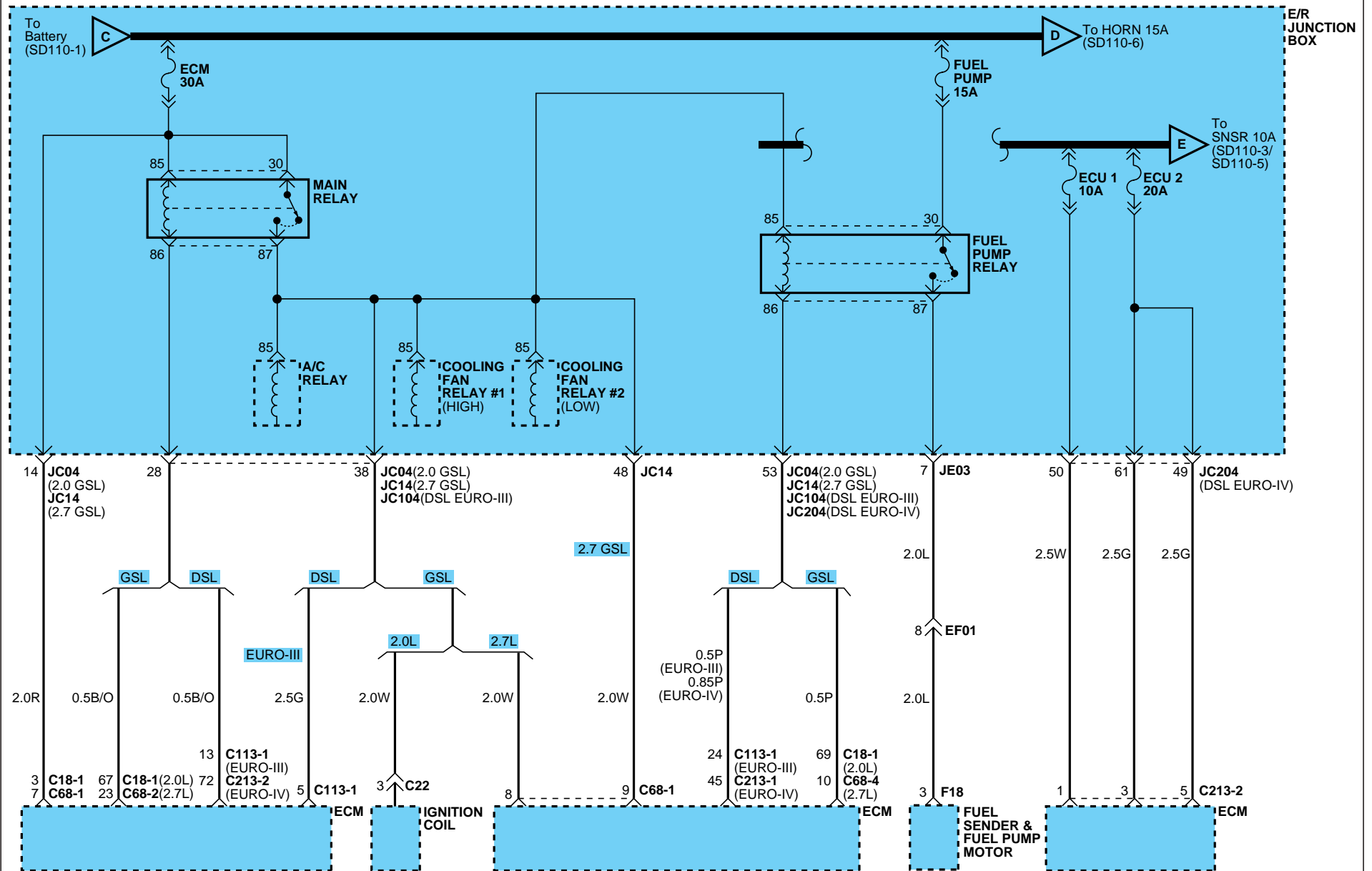

POWER DISTRIBUTION

POWER DISTRIBUTION (3)

SD110-3

GASOLINE / DIESEL EURO-III

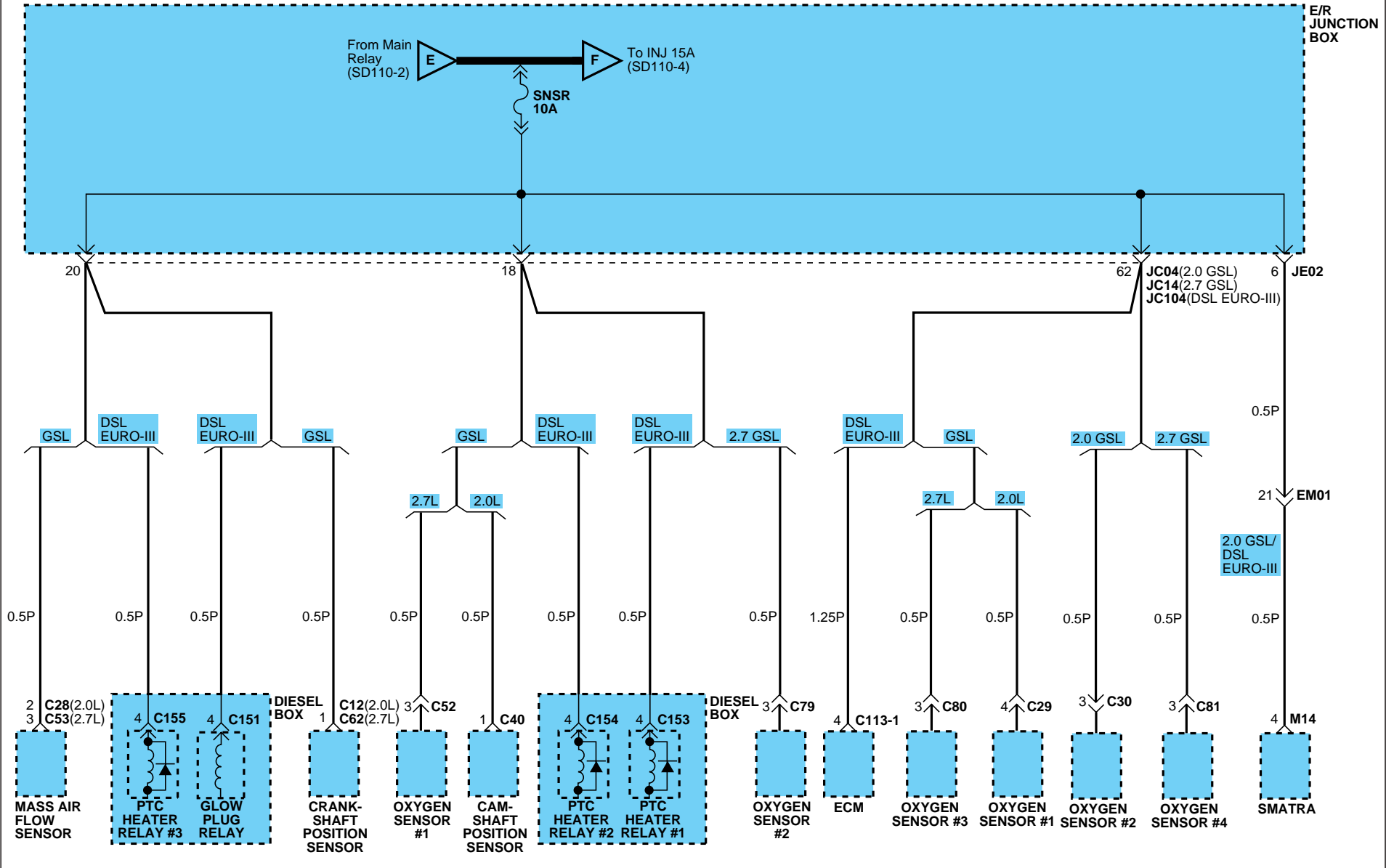

POWER DISTRIBUTION

POWER DISTRIBUTION (4)

SD110-4

GASOLINE / DIESEL EURO-III

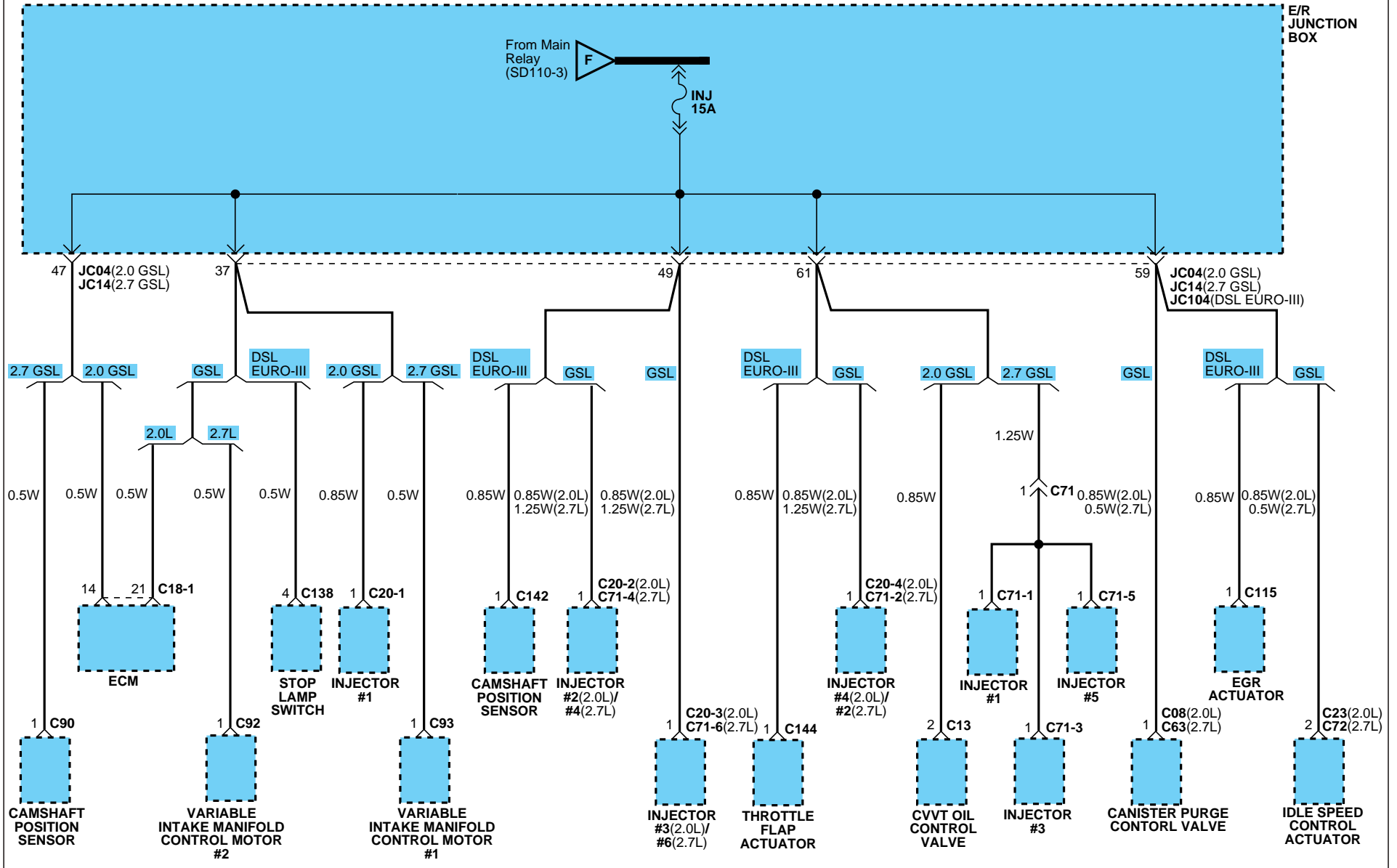

POWER DISTRIBUTION

POWER DISTRIBUTION (5)

SD110-5

DIESEL EURO-IV

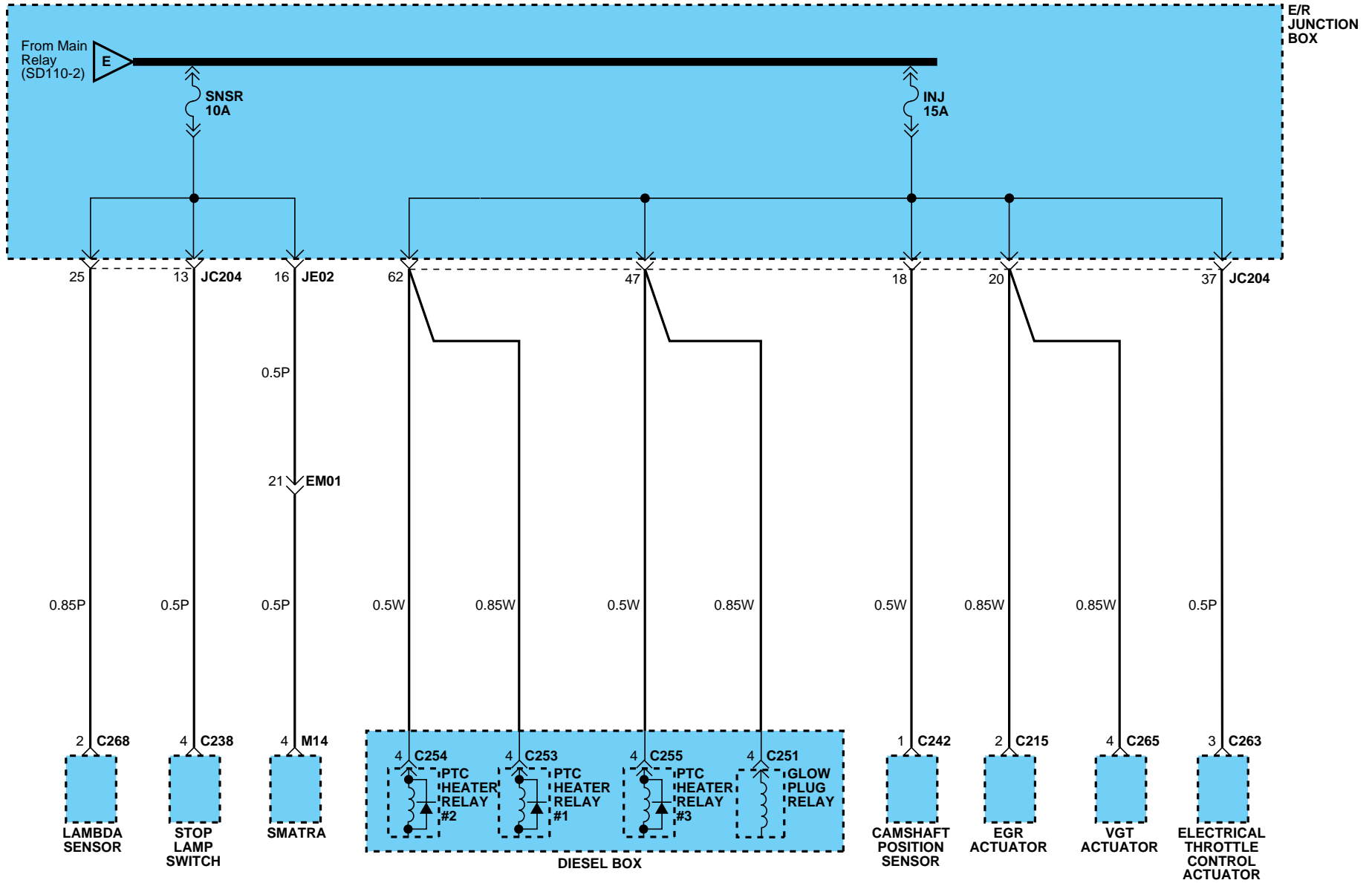

POWER DISTRIBUTION

POWER DISTRIBUTION (6)

SD110-6

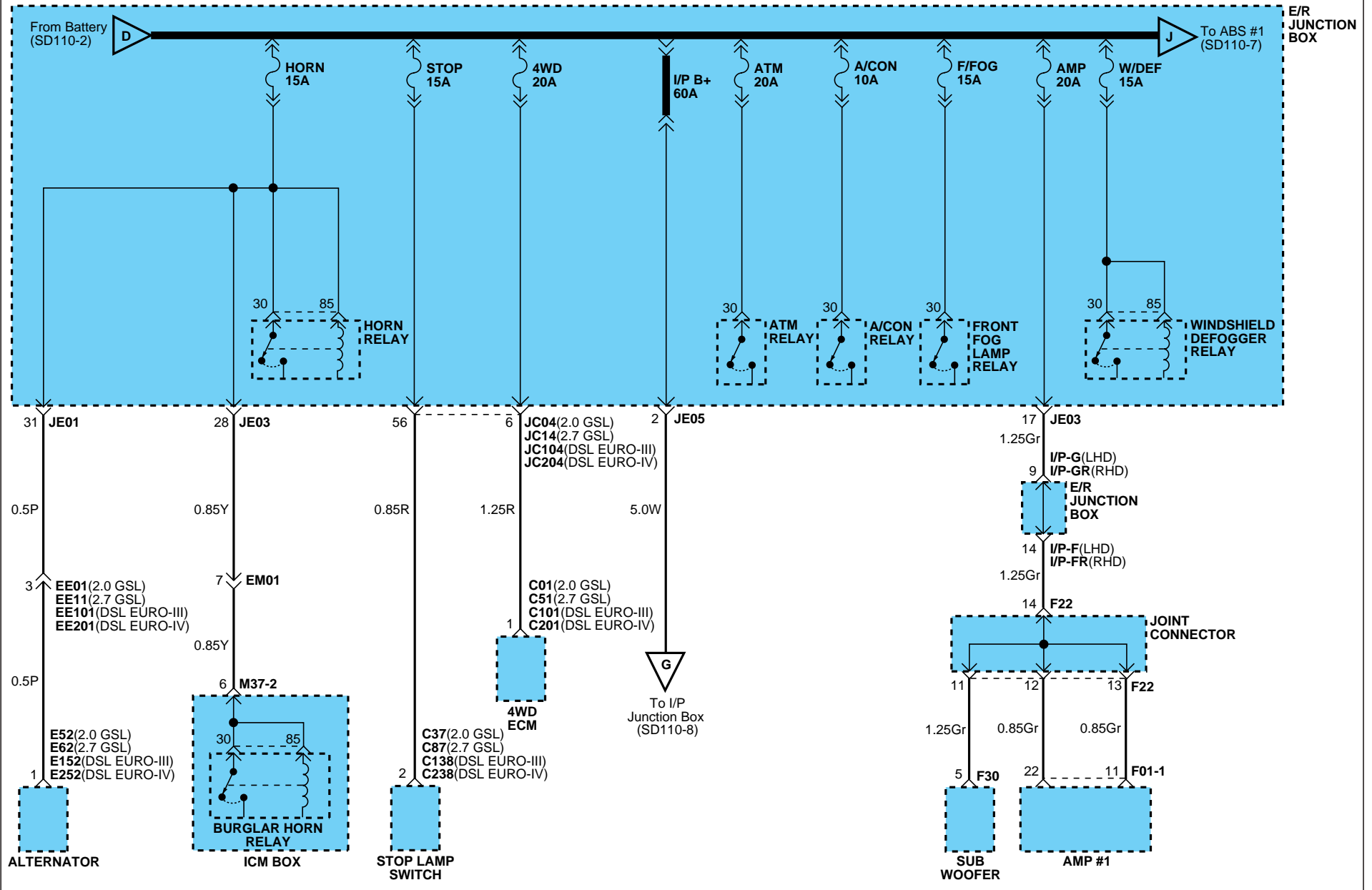

POWER DISTRIBUTION

POWER DISTRIBUTION (7)

SD110-7

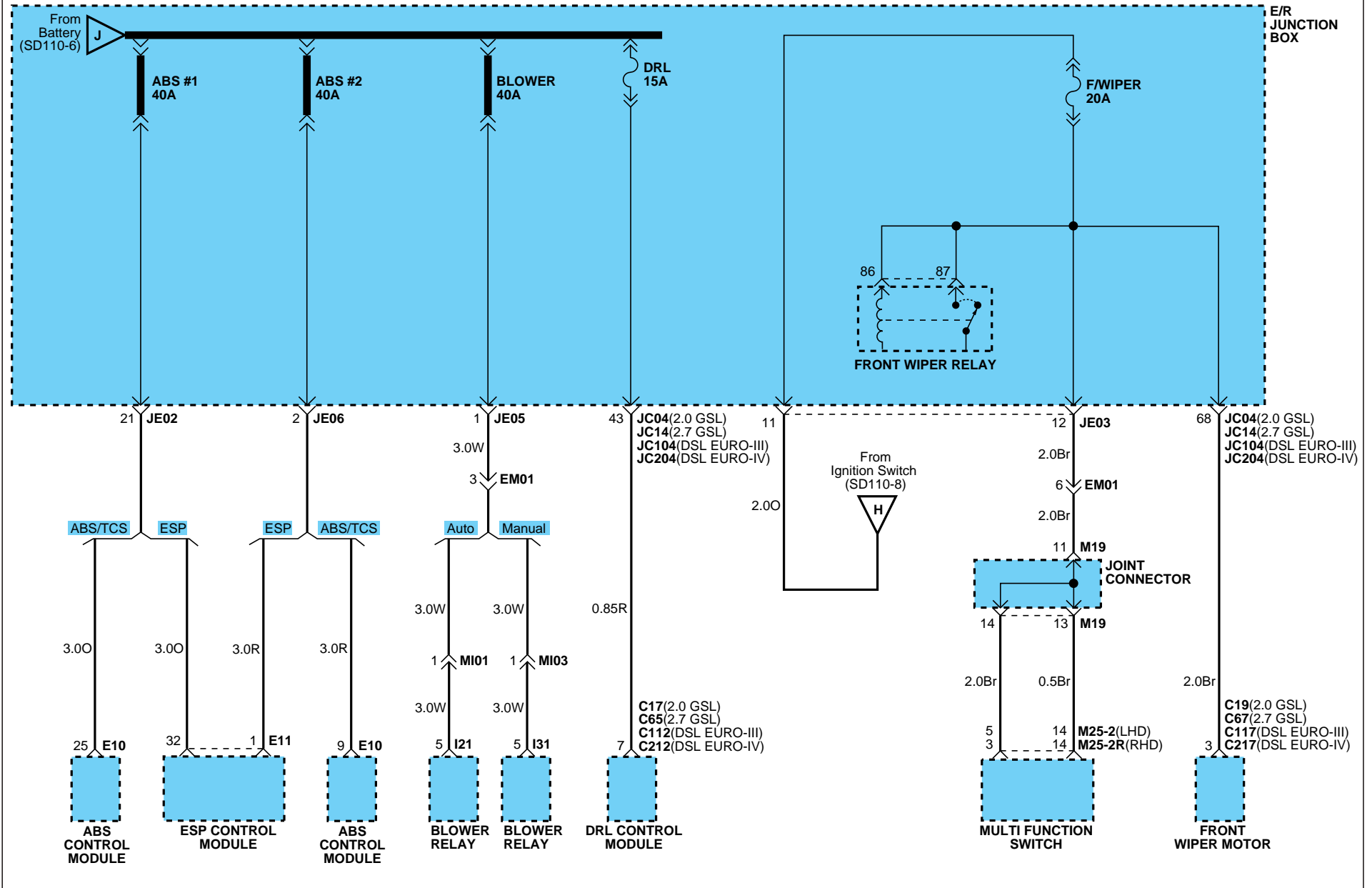

POWER DISTRIBUTION

POWER DISTRIBUTION (8)

SD110-8

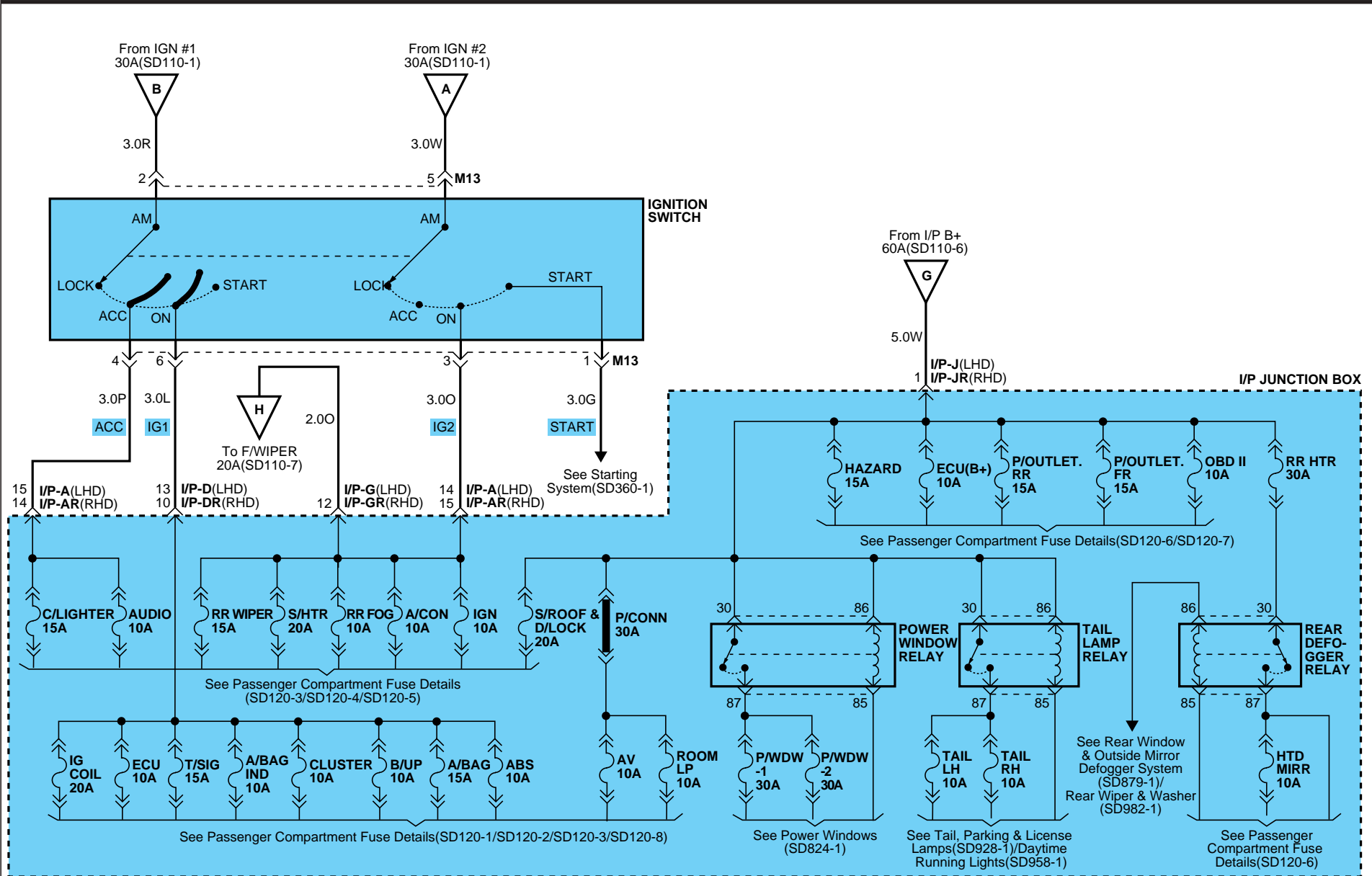

PASSENGER COMPARTMENT FUSE DETAILS (1)

SD120-1

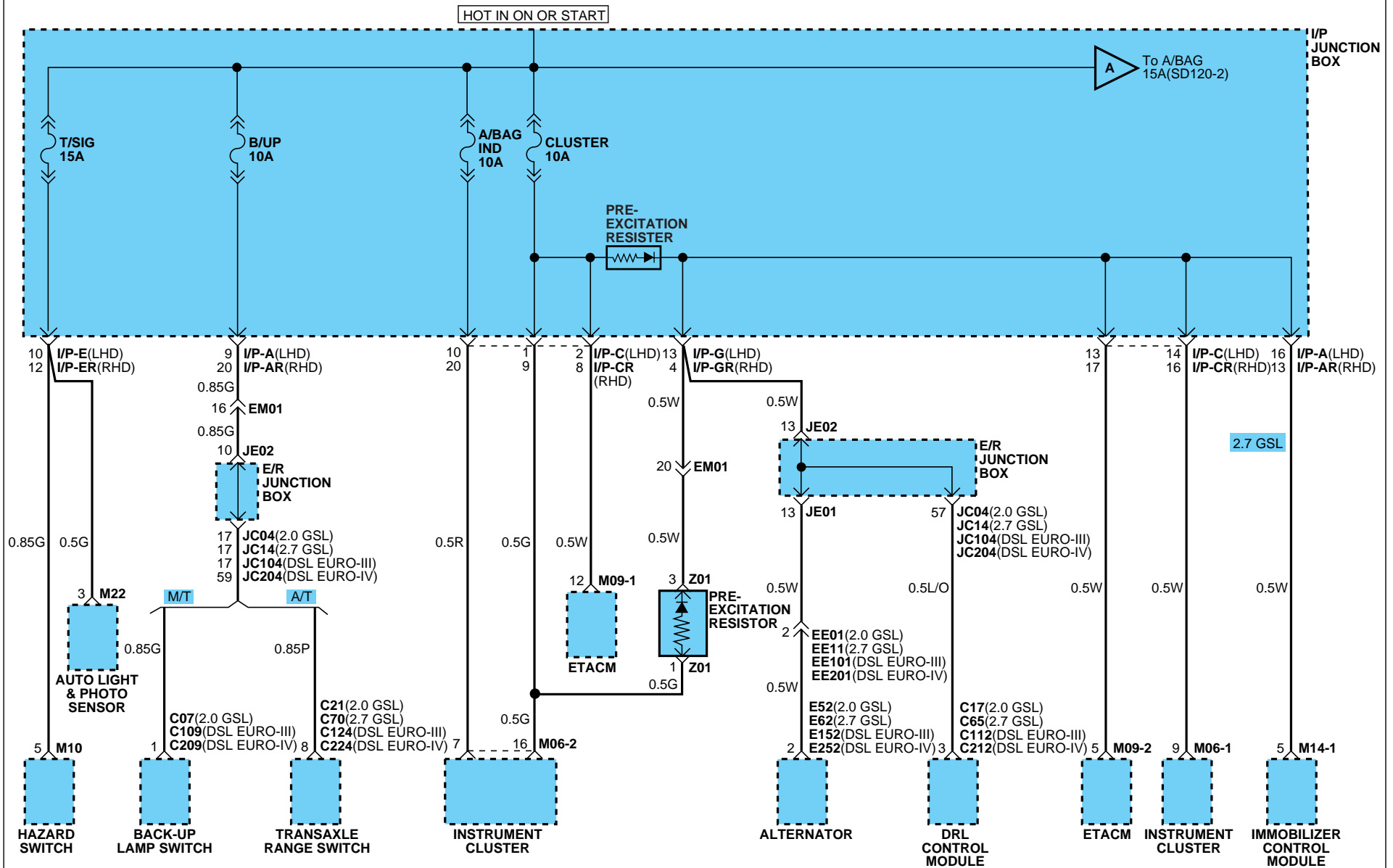

PASSENGER COMPARTMENT FUSE DETAILS

PASSENGER COMPARTMENT FUSE DETAILS (2)

SD120-2

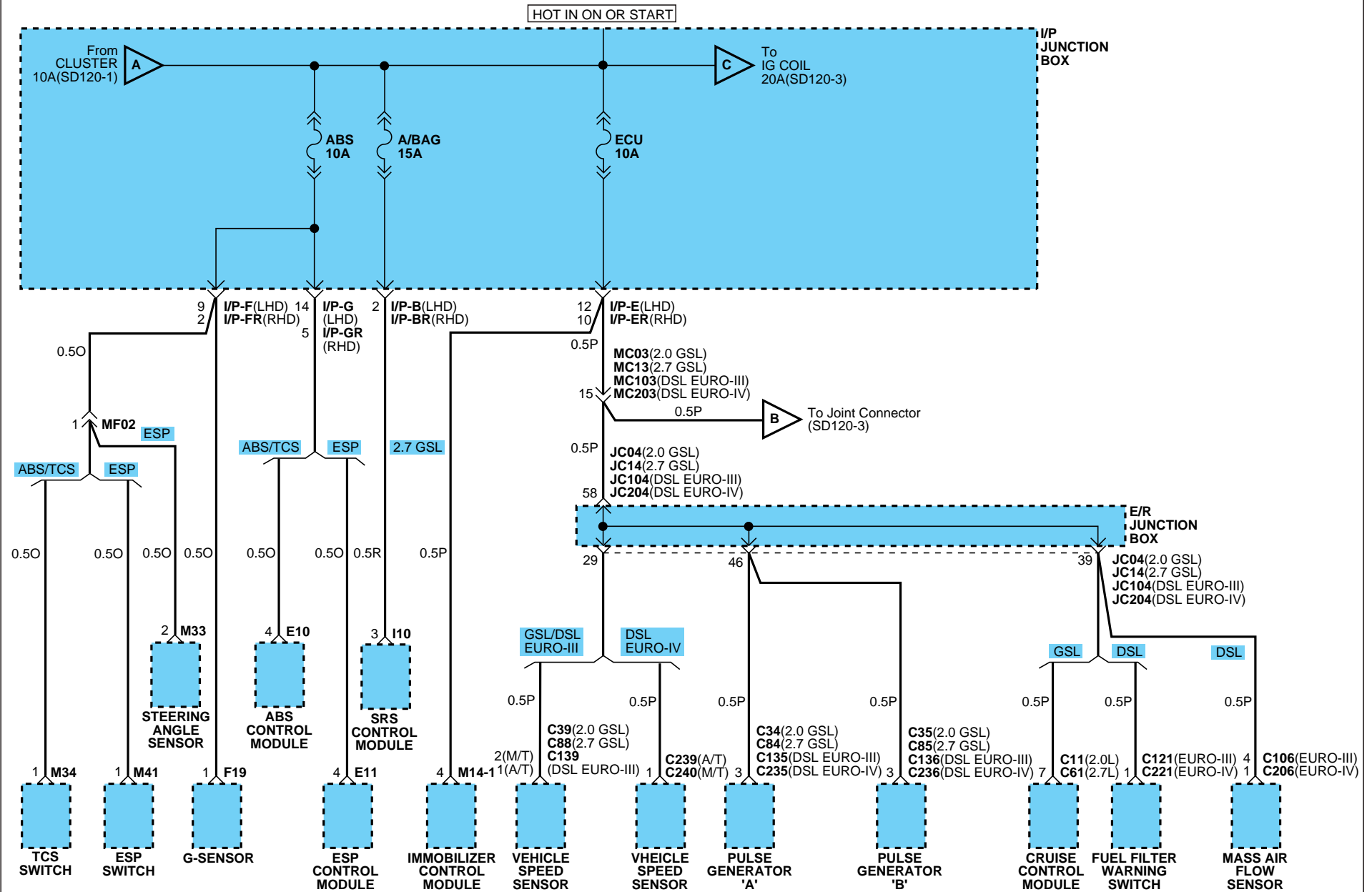

PASSENGER COMPARTMENT FUSE DETAILS

PASSENGER COMPARTMENT FUSE DETAILS (3)

SD120-3

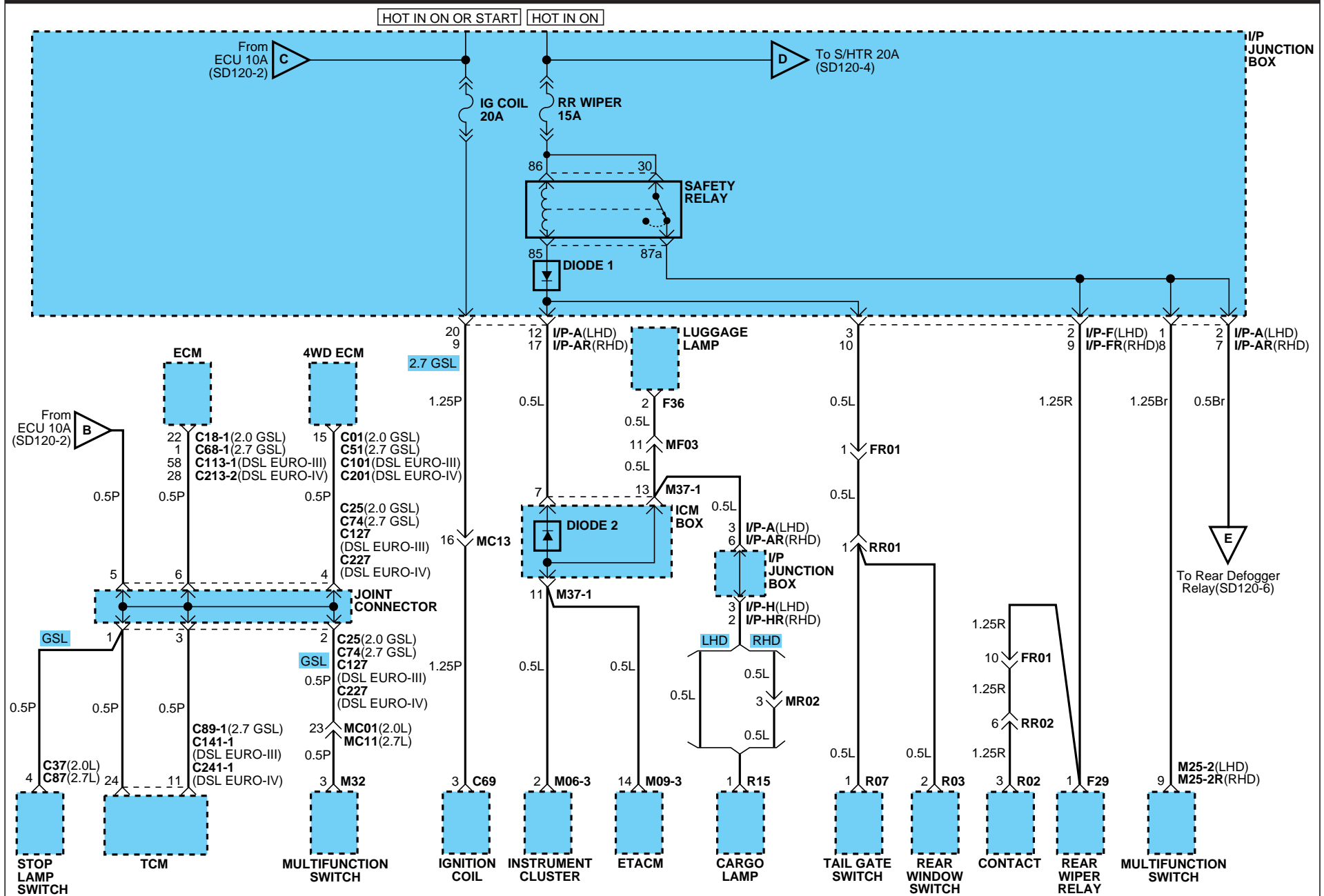

PASSENGER COMPARTMENT FUSE DETAILS

PASSENGER COMPARTMENT FUSE DETAILS (4)

SD120-4

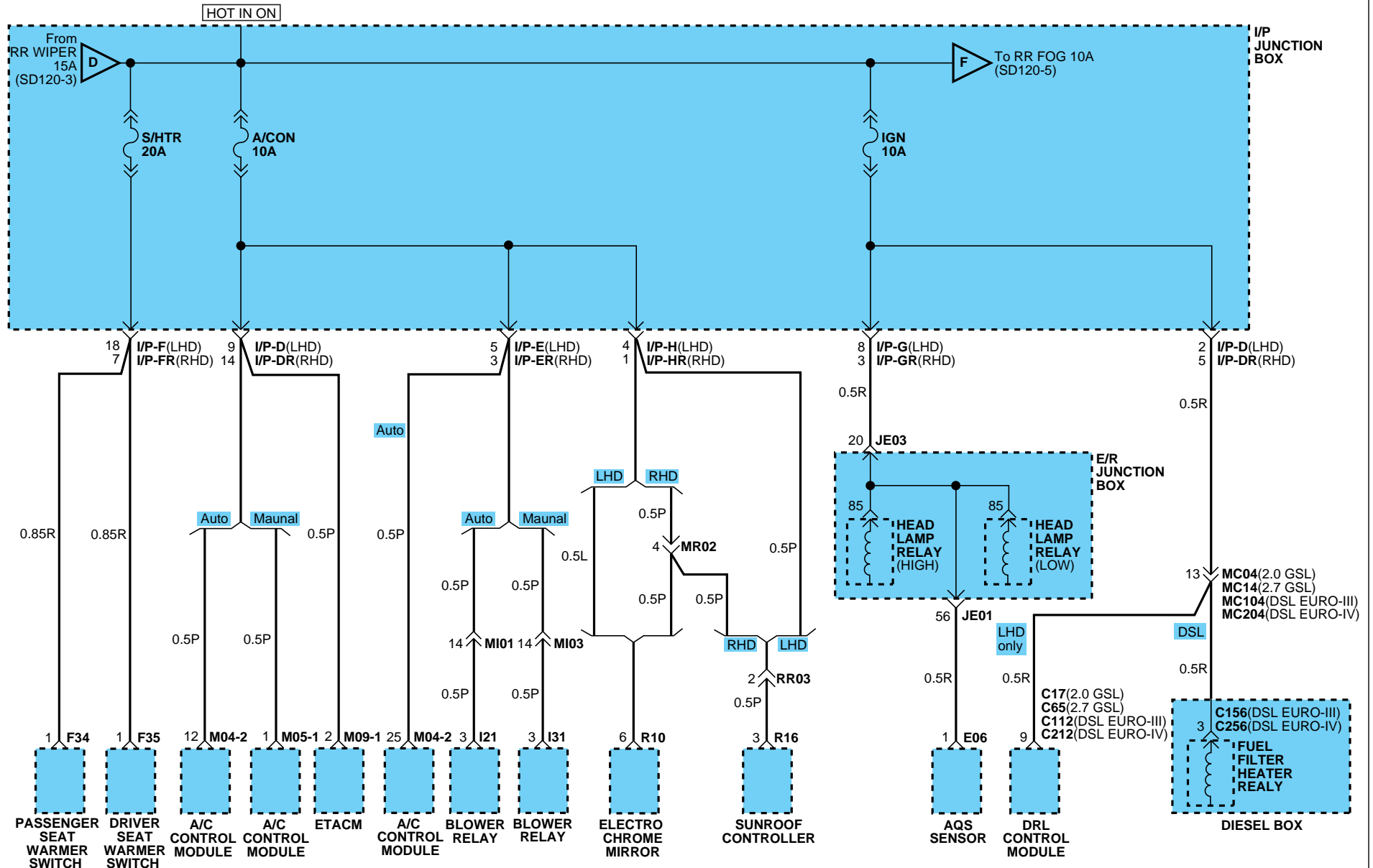

PASSENGER COMPARTMENT FUSE DETAILS

PASSENGER COMPARTMENT FUSE DETAILS (5)

SD120-5

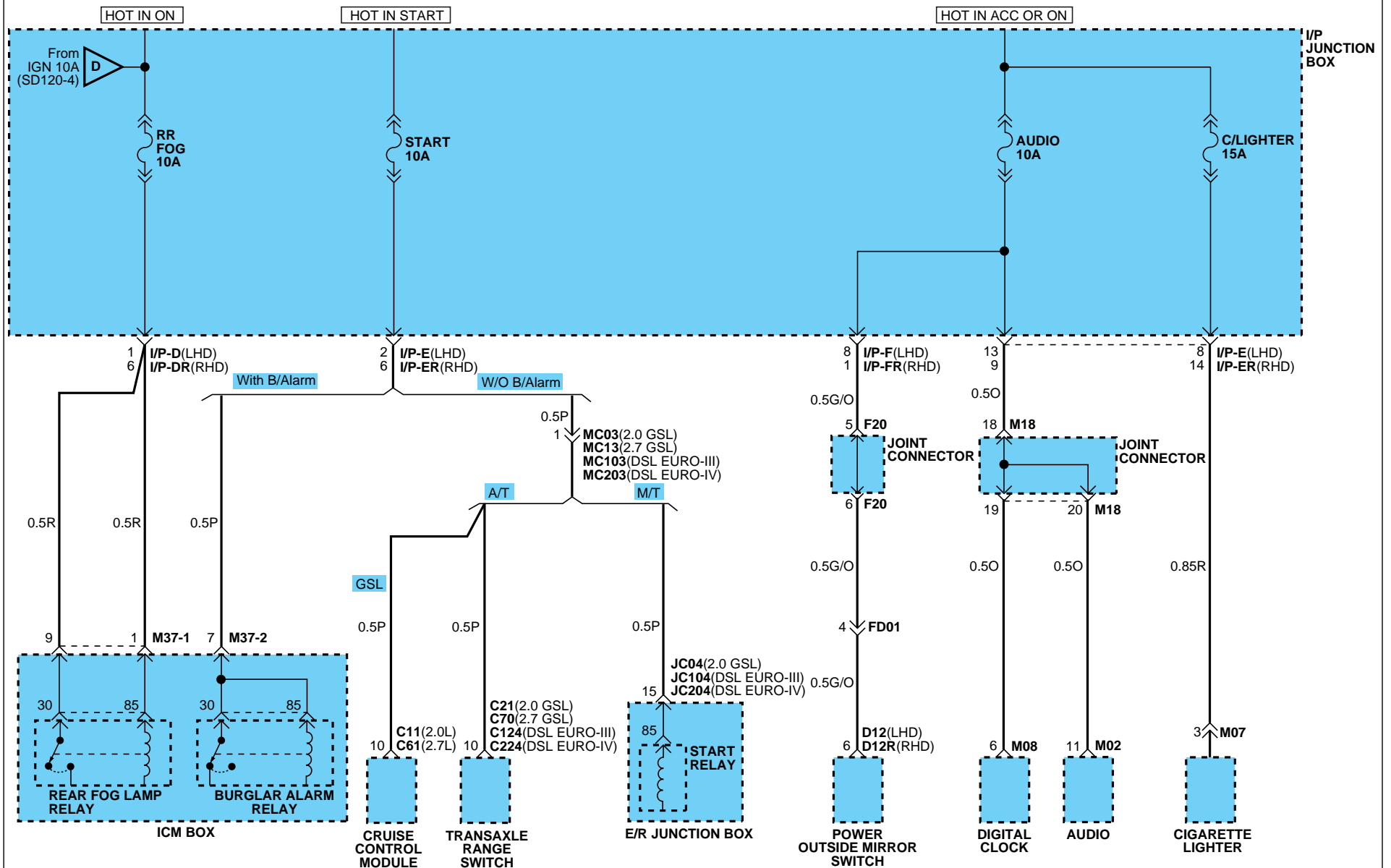

PASSENGER COMPARTMENT FUSE DETAILS

PASSENGER COMPARTMENT FUSE DETAILS (6)

SD120-6

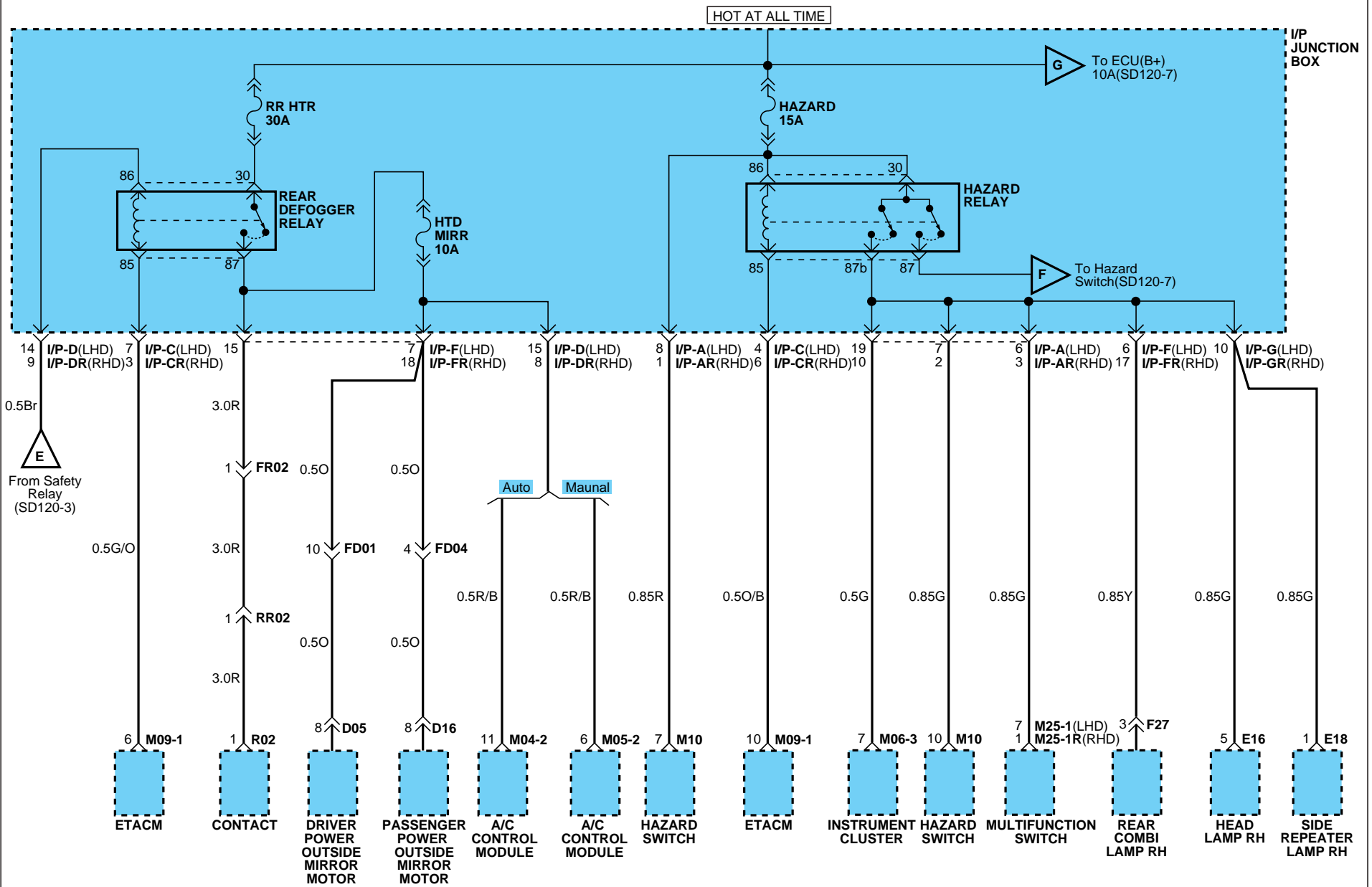

PASSENGER COMPARTMENT FUSE DETAILS

PASSENGER COMPARTMENT FUSE DETAILS (7)

SD120-7

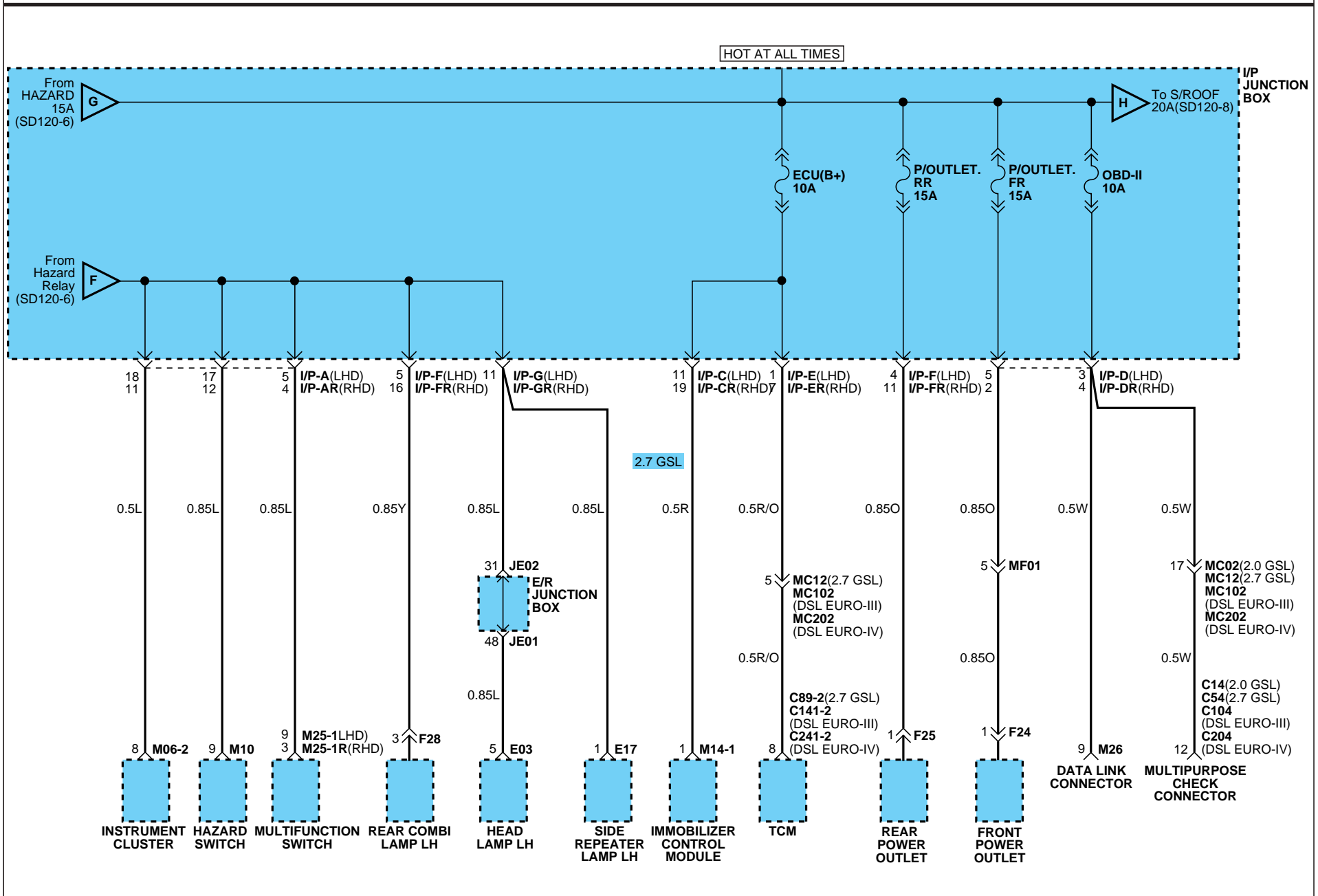

PASSENGER COMPARTMENT FUSE DETAILS

PASSENGER COMPARTMENT FUSE DETAILS (8)

SD120-8

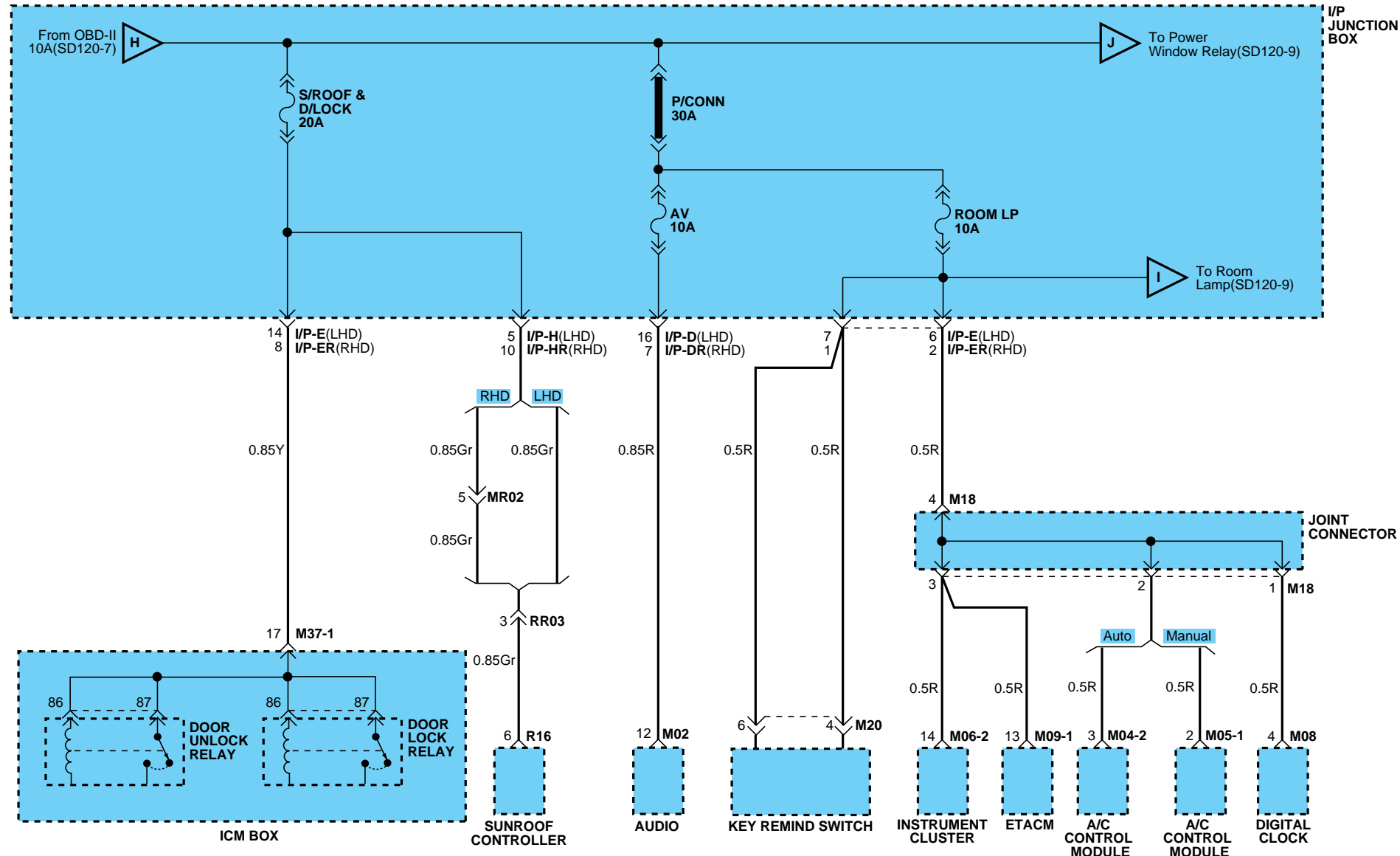

PASSENGER COMPARTMENT FUSE DETAILS

PASSENGER COMPARTMENT FUSE DETAILS (9)

SD120-9

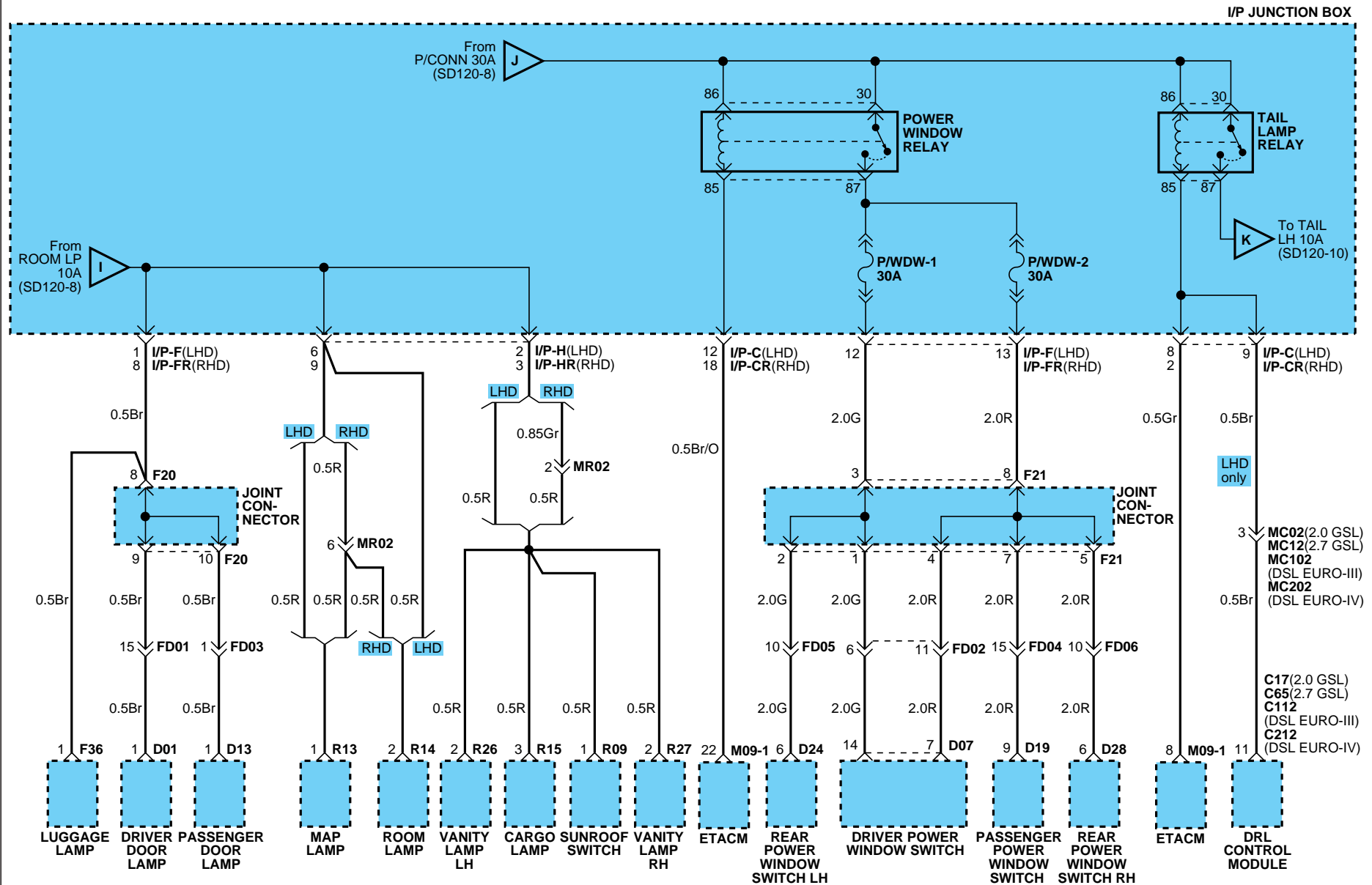

PASSENGER COMPARTMENT FUSE DETAILS

PASSENGER COMPARTMENT FUSE DETAILS (10)

SD120-10

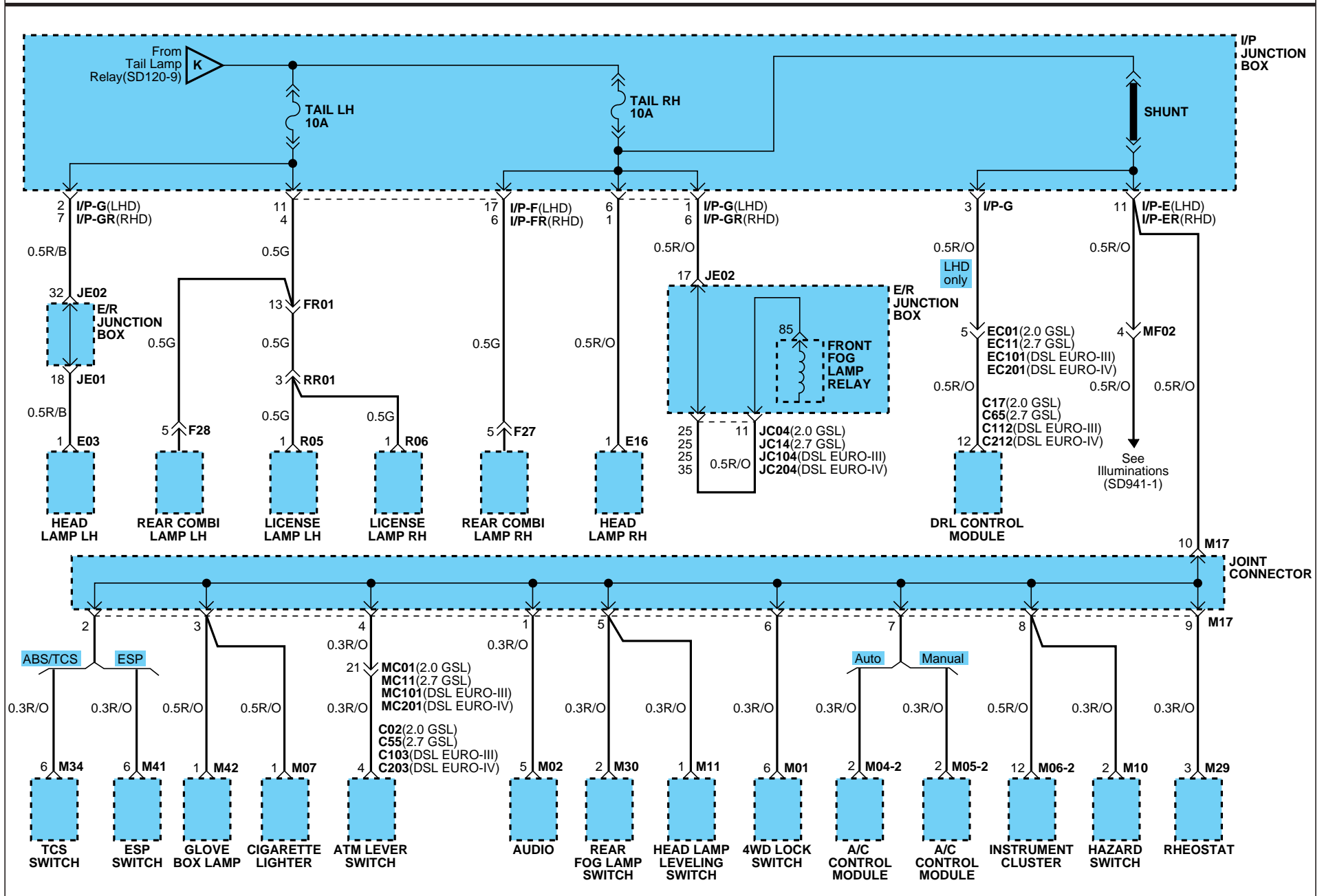

GROUND DISTRIBUTION (1)

SD130-1

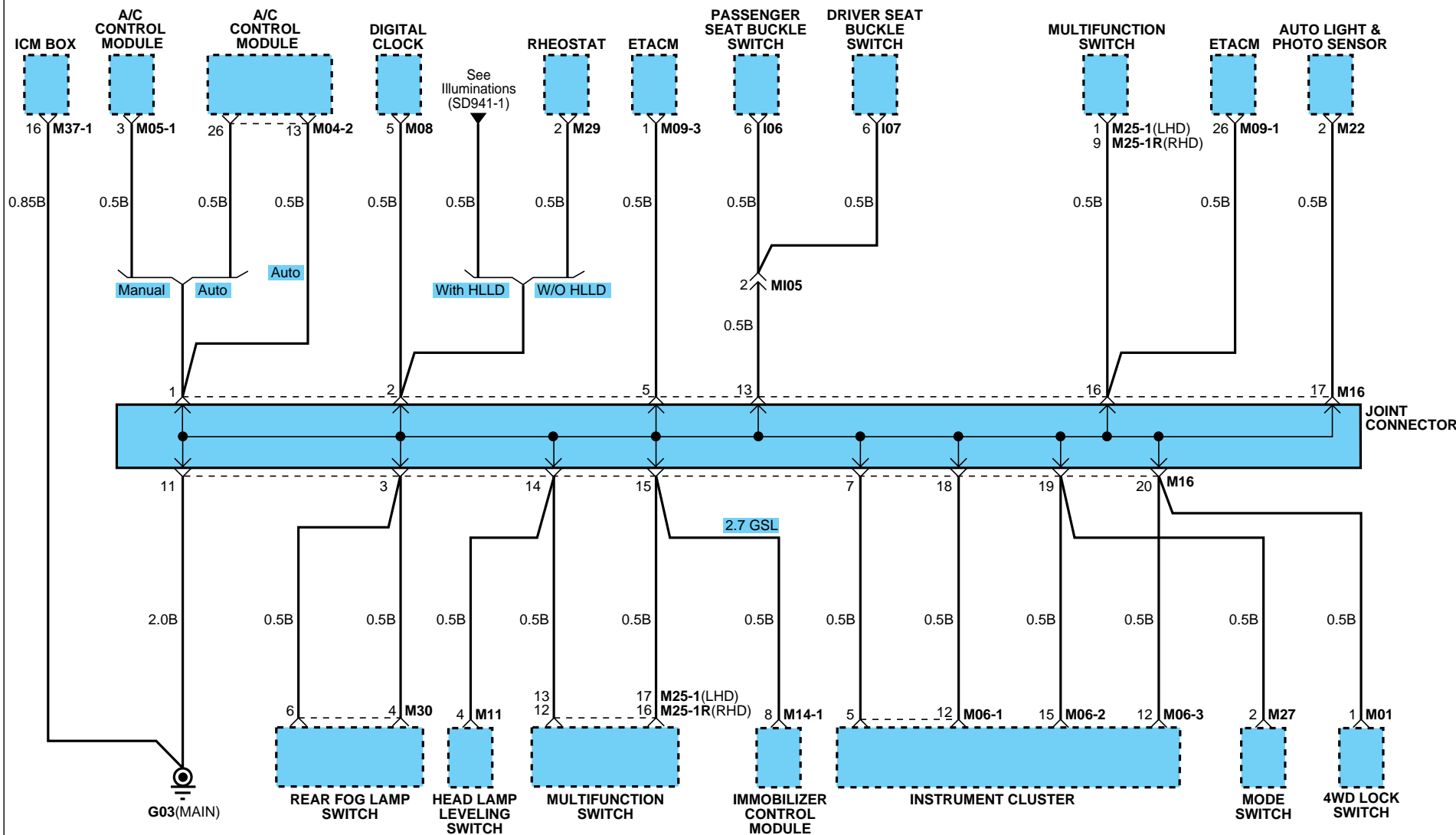

GROUND DISTRIBUTION

GROUND DISTRIBUTION (2)

SD130-2

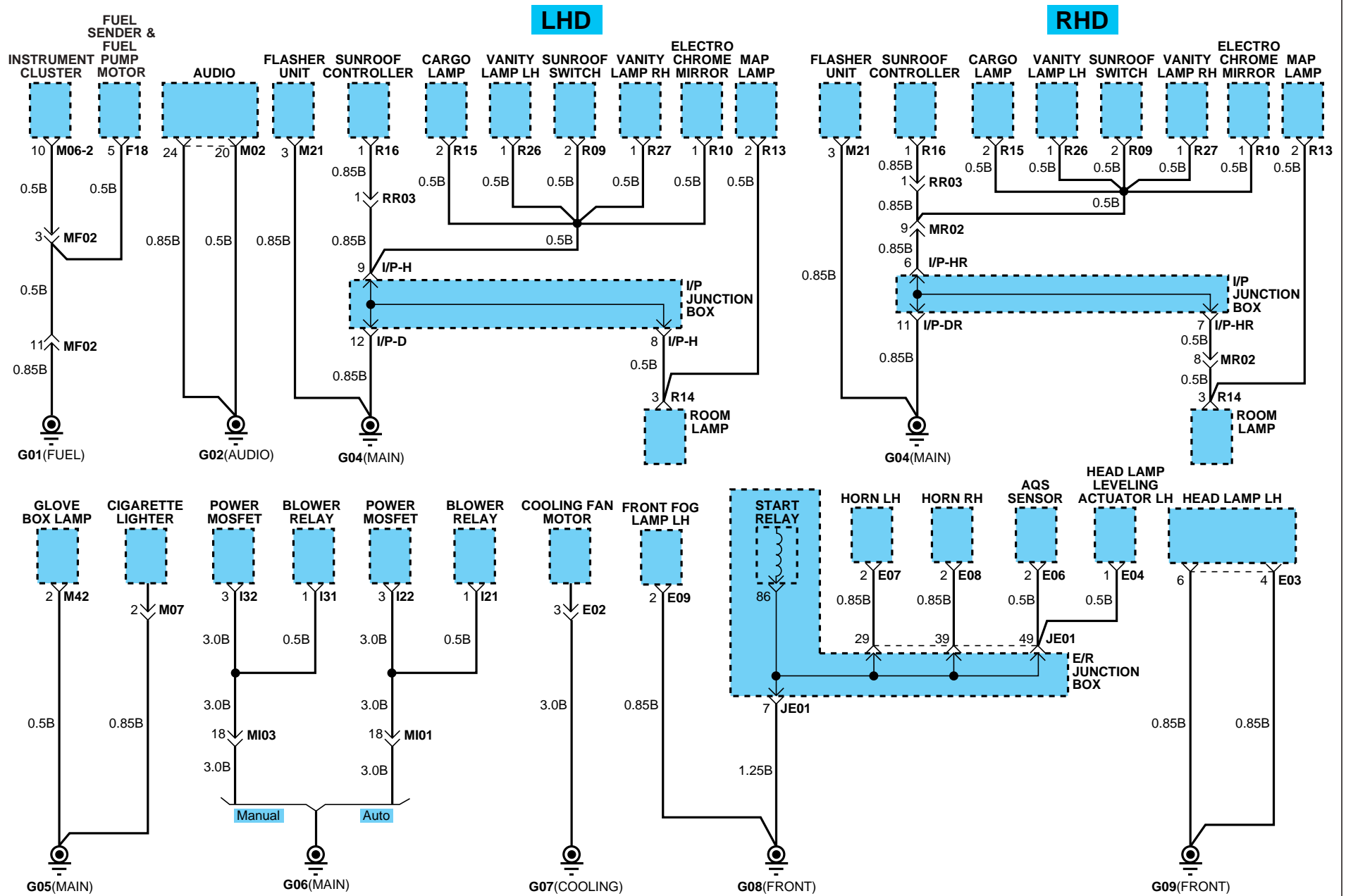

GROUND DISTRIBUTION

GROUND DISTRIBUTION (3)

SD130-3

2.0 GASOLINE

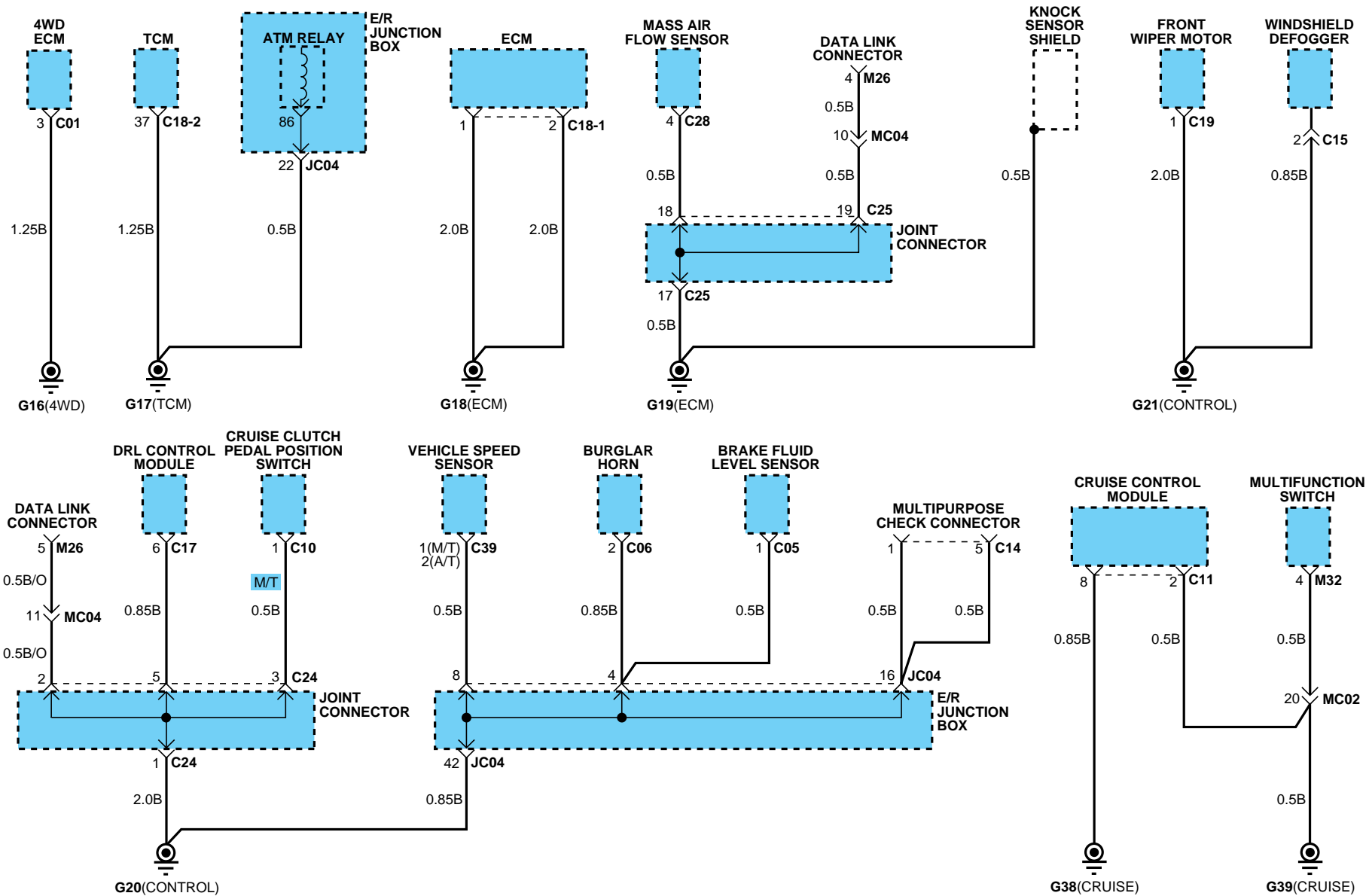

GROUND DISTRIBUTION

GROUND DISTRIBUTION (4)

SD130-4

2.7 GASOLINE

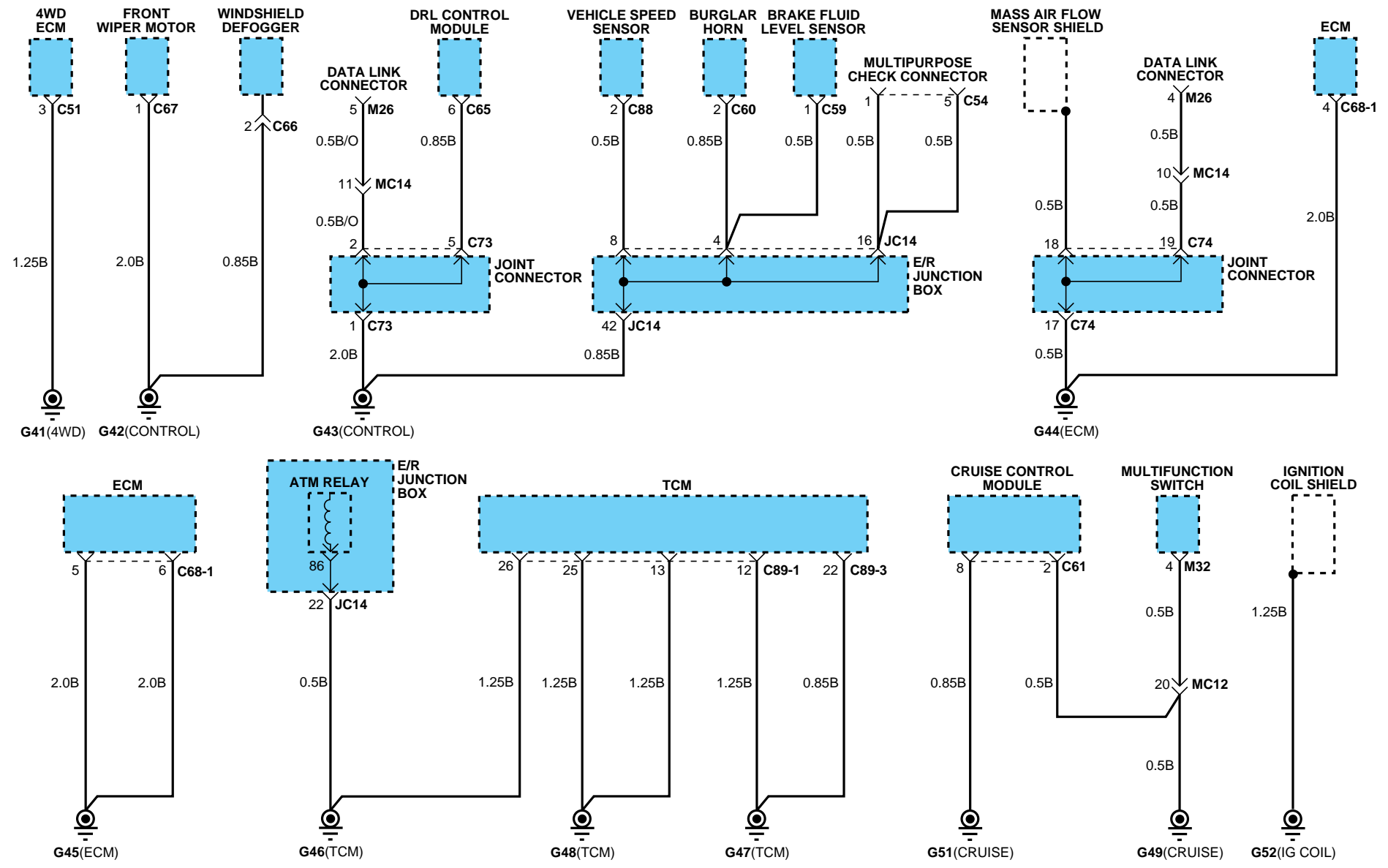

GROUND DISTRIBUTION

GROUND DISTRIBUTION (5)

SD130-5

DIESEL EURO-III

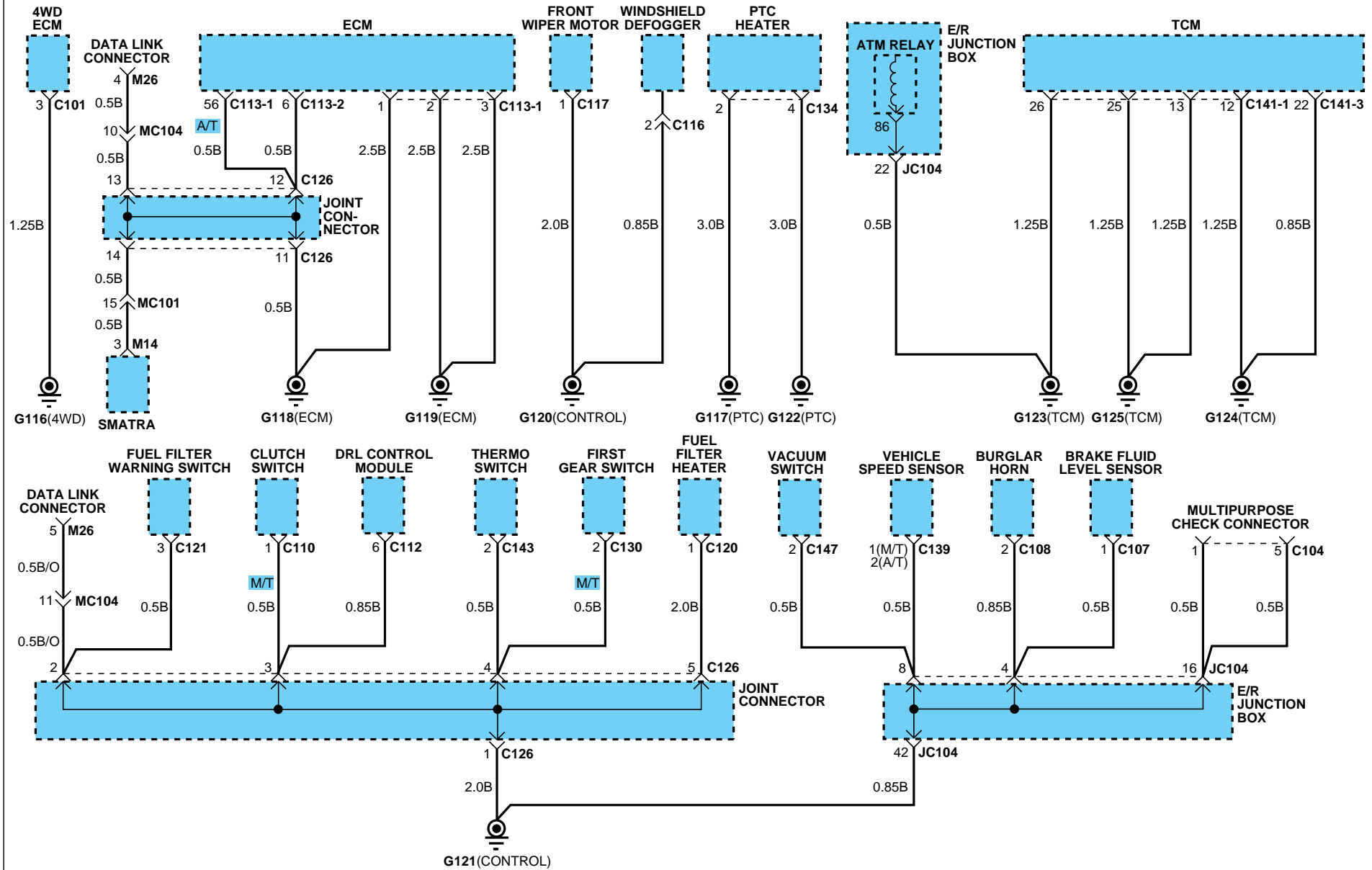

GROUND DISTRIBUTION

GROUND DISTRIBUTION (6)

SD130-6

DIESEL EURO-IV

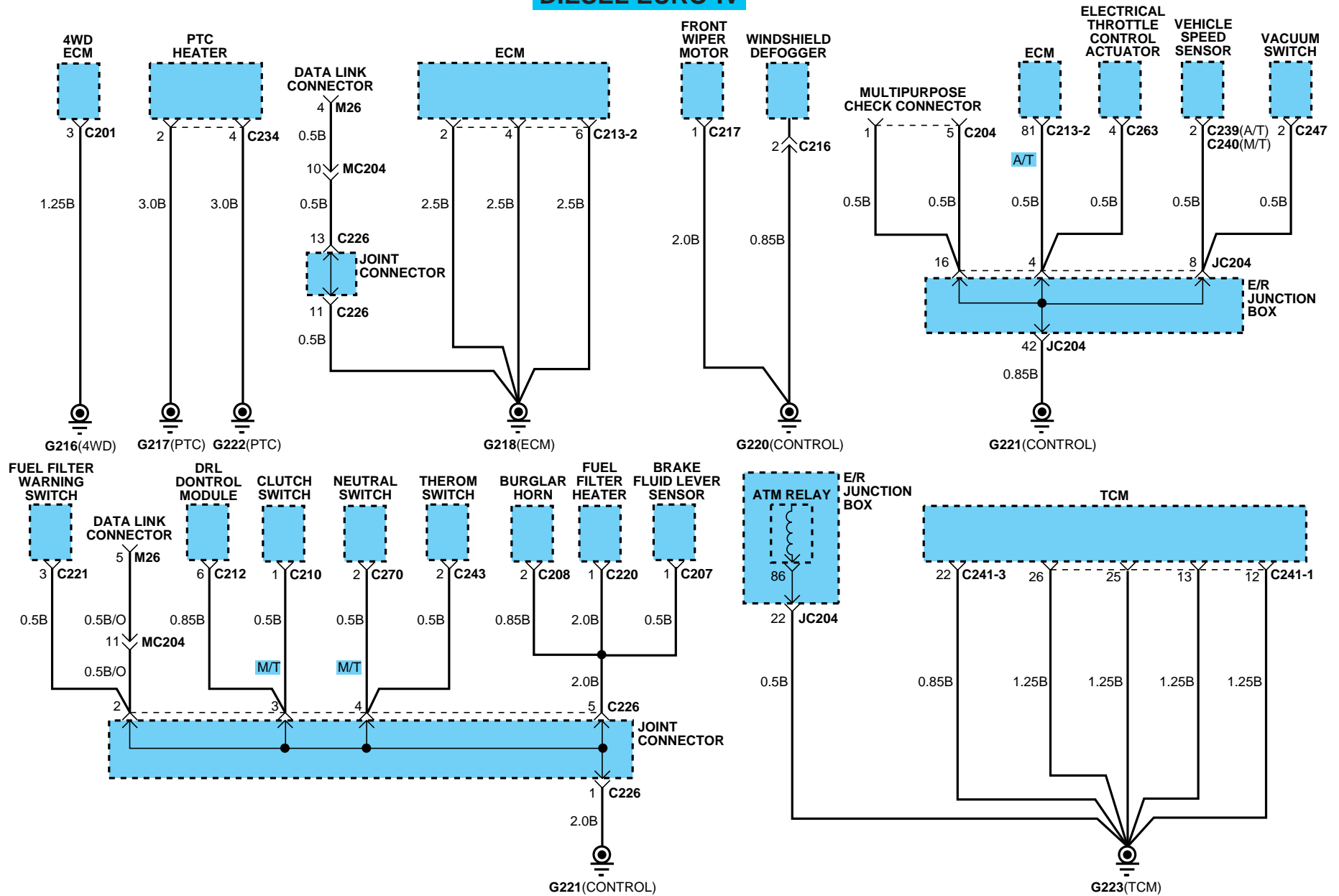

GROUND DISTRIBUTION

GROUND DISTRIBUTION (7)

SD130-7

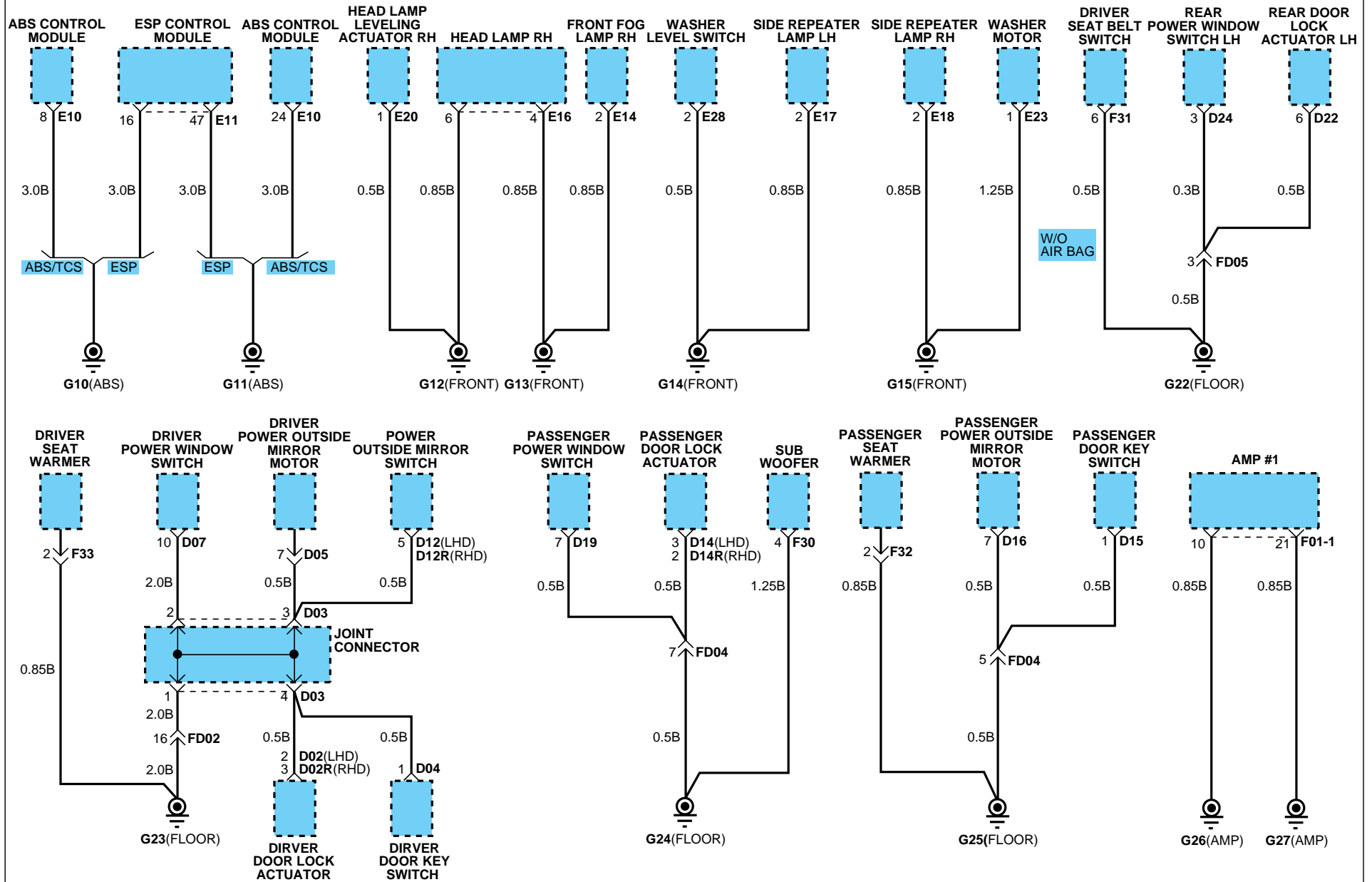

GROUND DISTRIBUTION

GROUND DISTRIBUTION (8)

SD130-8

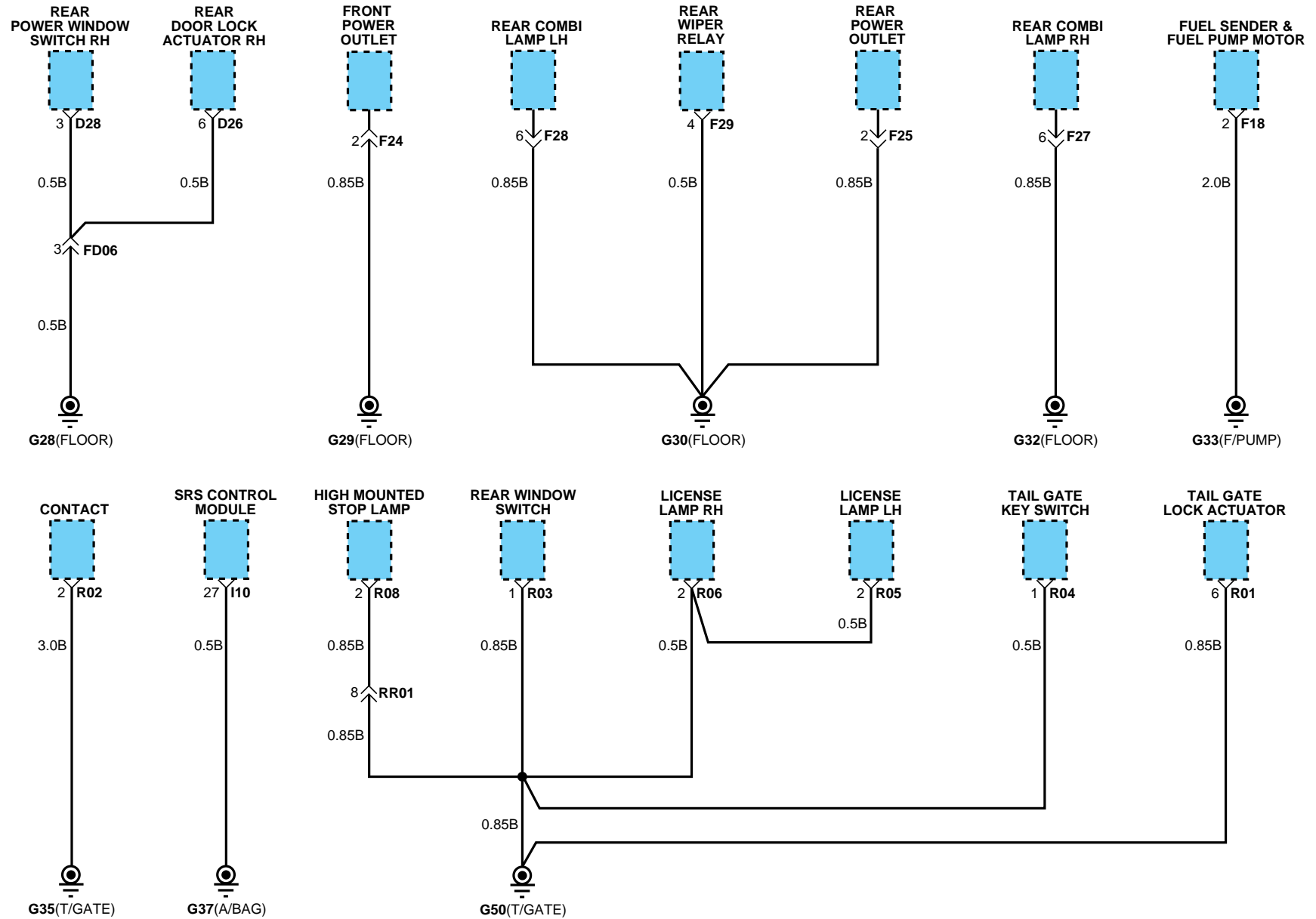

DATA LINK DETAILS

E092B9C2

DATA LINK DETAILS (1)

SD200-1

C24, C25, MC02 : 2.0 GSL
C73, C74, MC12 : 2.7 GSL
C126, MC102 : DSL EURO-III
C226, MC202 : DSL EURO-IV

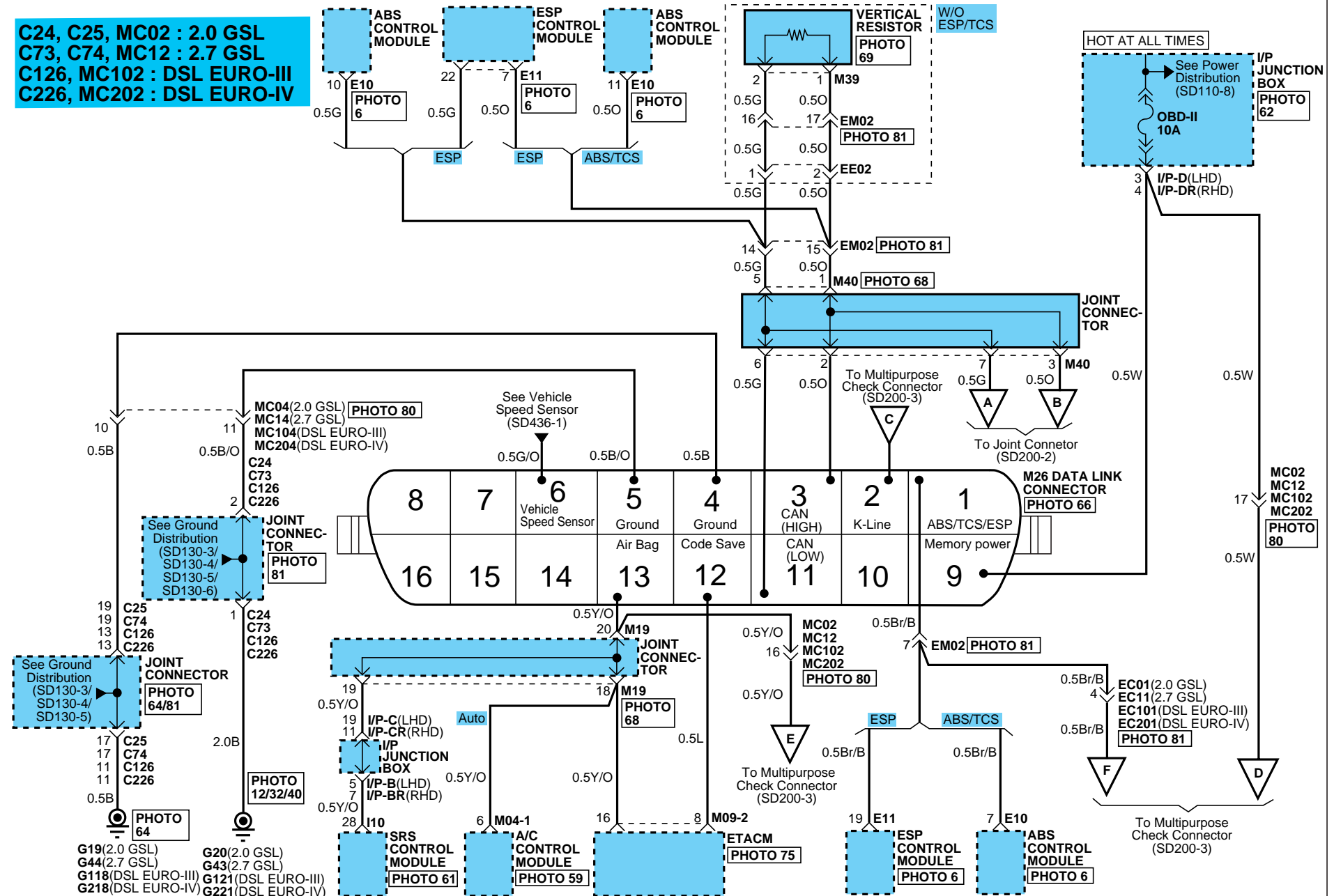

DATA LINK DETAILS

DATA LINK DETAILS (2)

SD200-2

2.0 GSL

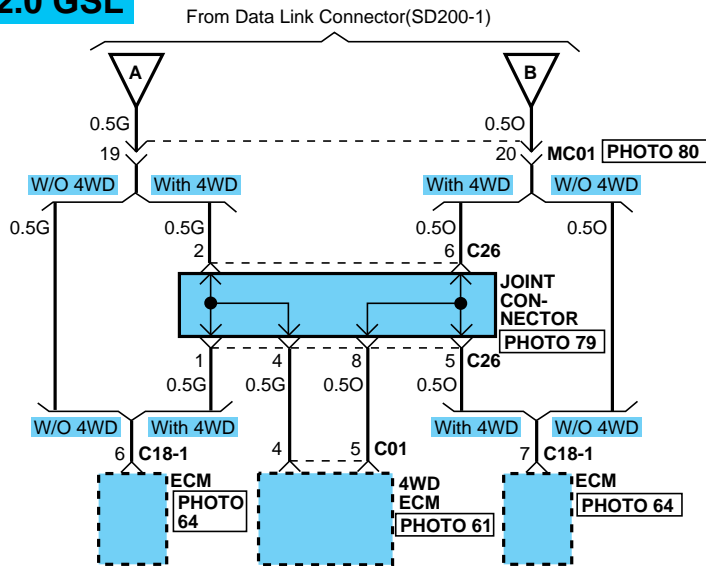

DIESEL

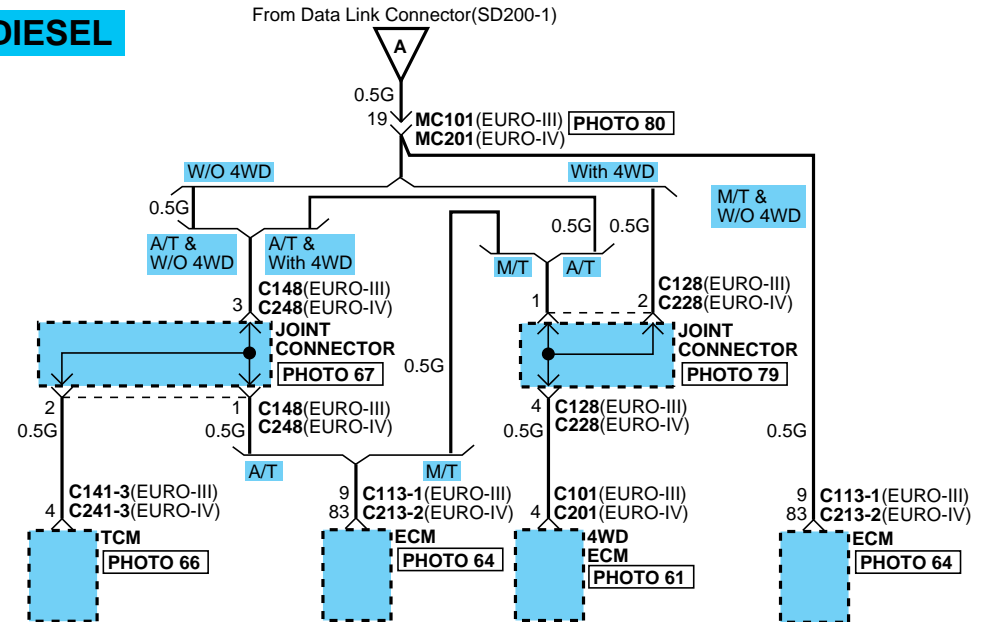

2.7 GSL

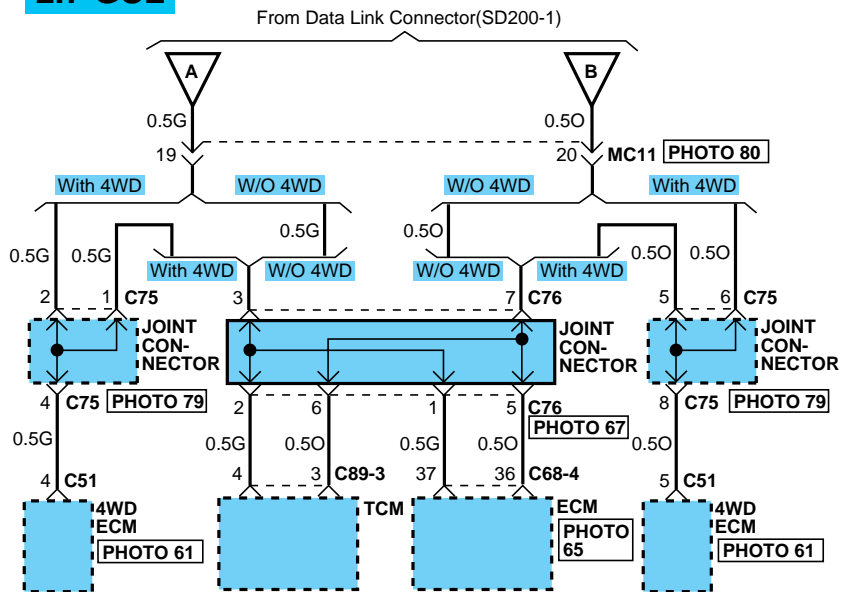

DIESEL

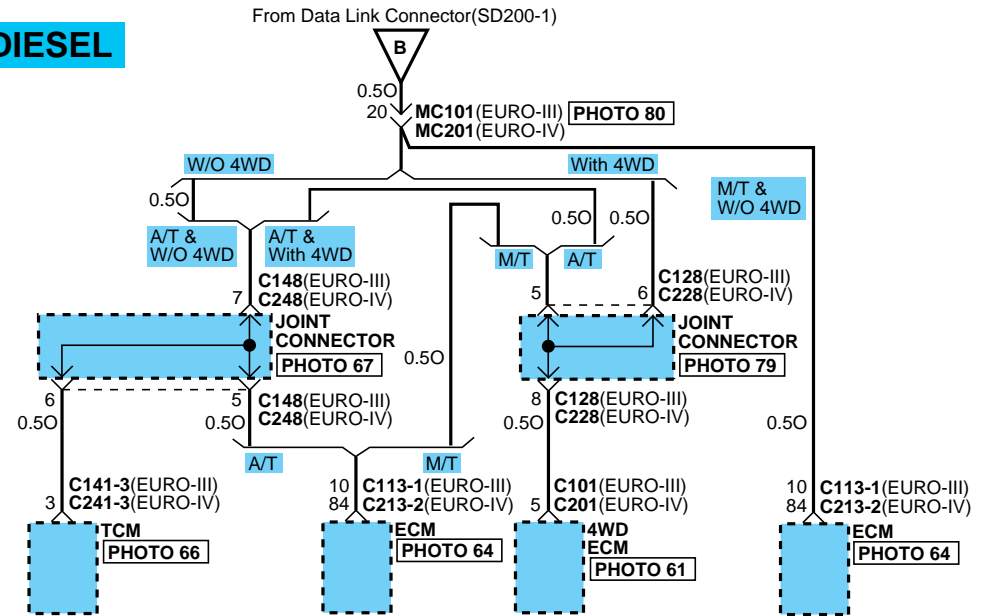

DATA LINK DETAILS

DATA LINK DETAILS (3)

SD200-3

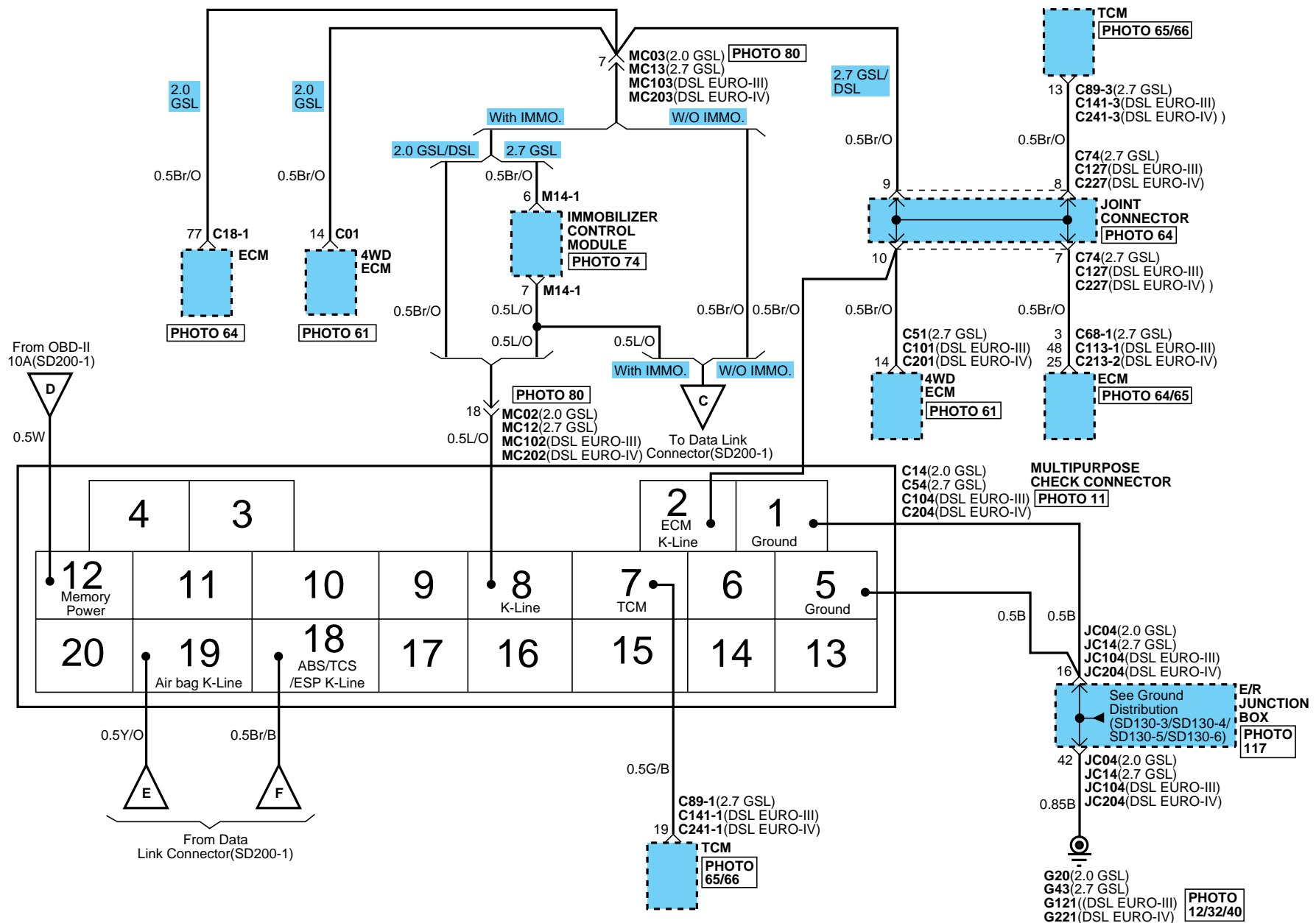

DATA LINK DETAILS

DATA LINK DETAILS (4)

SD200-4

C14

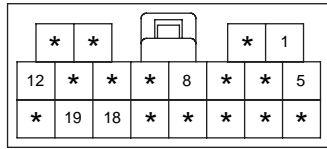

KET_DIAG_20F_B_CLIP

C18-1

6	7	8	9	10	11	*	*	14	*	*	17	18	*	*	21	22	23	24	5	4
*	26	27	*	29	30	31	32	*	*	*	*	37	38	39	*	*	42	43	3	
*	45	*	47	48	*	50	51	52	*	54	55	56	*	58	59	60	61	62		
*	64	65	66	67	68	69	70	71	72	73	*	75	76	77	78	*	80	81	2	1

KET_ECU_81F

C54/C104

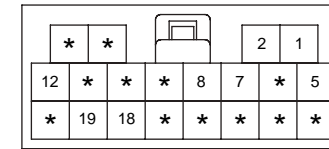

KET_DIAG_20F_B_CLIP

C68-3

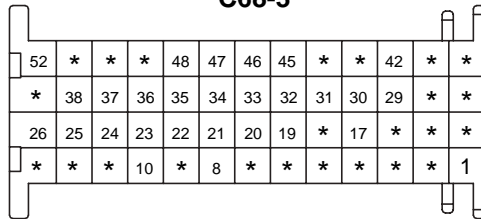

AMP_ECU_52F_B_134P

C113-1

*	*	*	9	10	11	12	13	14	15	16	17	18	19	20	21	*	23	24	5	4	
*	*	*	*	*	*	*	*	*	*	*	*	*	*	*	40	*	*	*	3		
*	*	*	47	48	49	*	51	52	53	54	*	56	*	58	59	60	61	62			
*	*	*	*	*	*	*	*	*	*	*	*	74	75	76	77	78	79	80	81	2	1

KET_ECU_81F

C204

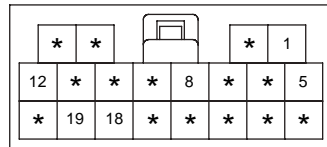

KET_DIAG_20F_B_CLIP

C213-2

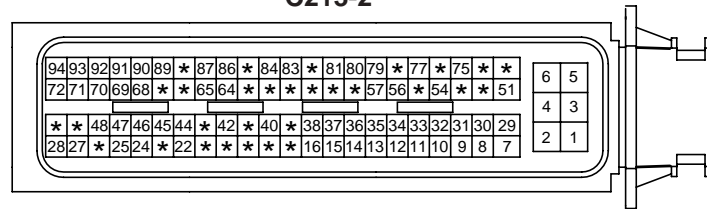

AMP_ECU_94F_B

M14-1

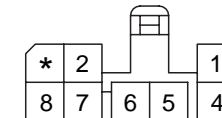

AMP_070_08F_W

M26

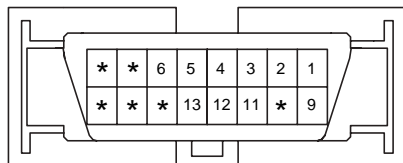

MLX_OBDII_16F_B_SIN

M39

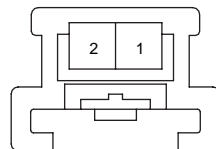

AMP_090_CAN_02F_W

BLANK

BLANK

COOLING SYSTEM (1)

SD253-1

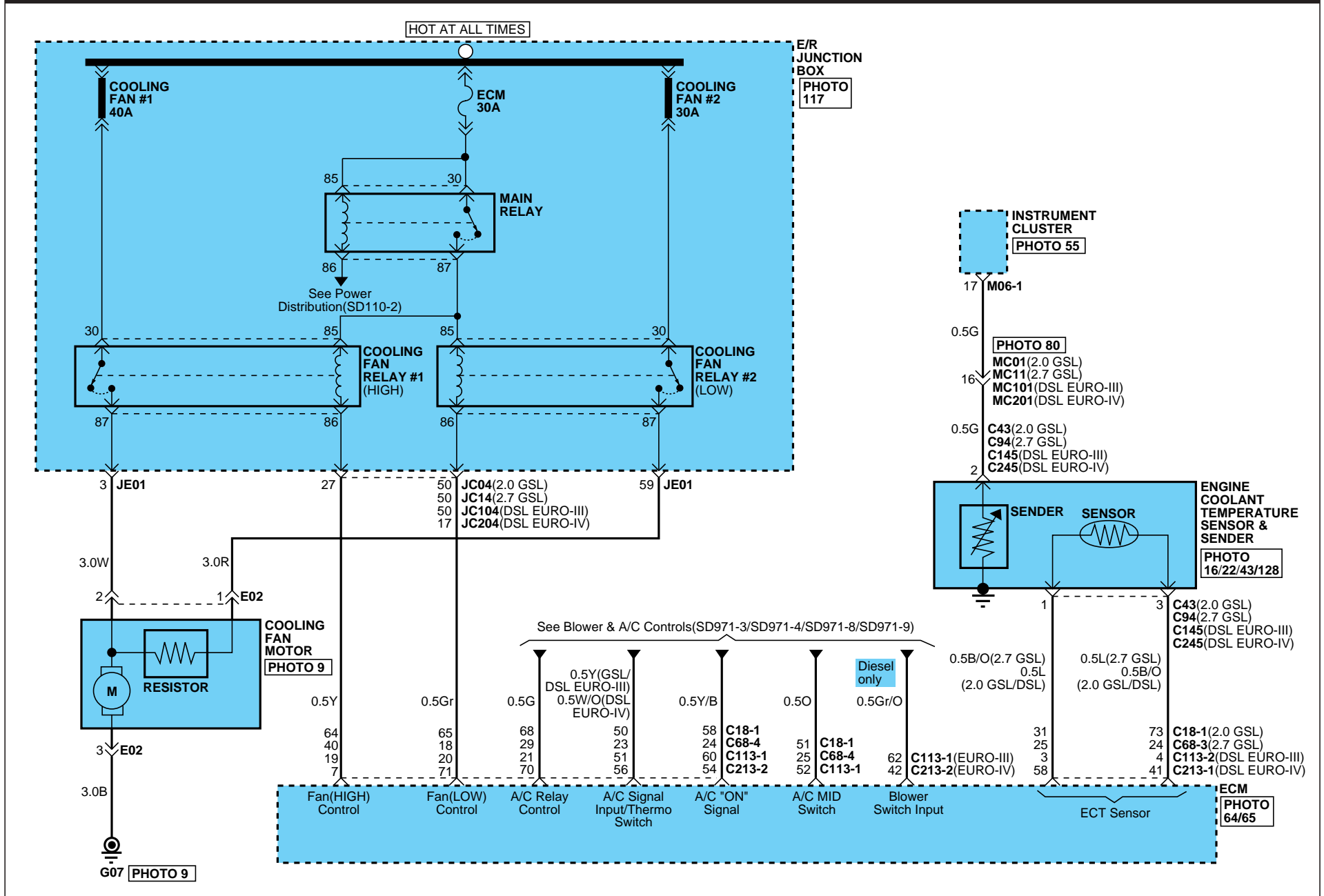

COOLING SYSTEM

COOLING SYSTEM (2)

SD253-2

C18-1

6	7	8	9	10	11	*	*	14	*	*	17	18	*	*	21	22	23	24	5	4
*	26	27	*	29	30	31	32	*	*	*	*	37	38	39	*	*	42	43	3	
*	45	*	47	48	*	50	51	52	*	54	55	56	*	58	59	60	61	62		
64	65	66	67	68	69	70	71	72	73	*	75	76	77	78	*	80	81	2	1	

KET_ECU_81F

C43/C145/C245

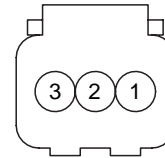

KUM_WTS_03F_B

BLANK

C68-3

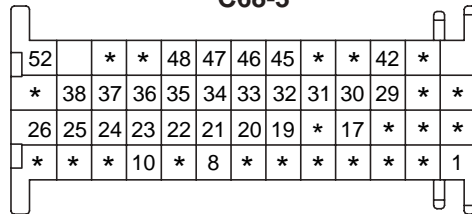

AMP_ECU_52F_B_134P

C68-4

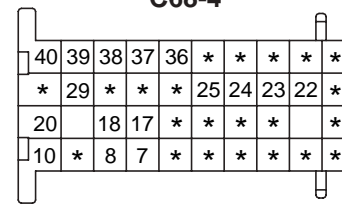

AMP_ECU_40F_B_134P

C94

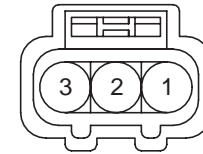

KUM_62Z_03F_B_WTS

C113-1

*	*	*	9	10	11	12	13	14	15	16	17	18	19	20	21	*	23	24	5	4	
*	*	*	*	*	*	*	*	*	*	*	*	*	*	*	40	*	*	*	3		
*	*	*	47	48	49	*	51	52	53	54	*	56	*	58	59	60	61	62			
*	*	*	*	*	*	*	*	*	*	*	*	74	75	76	77	78	79	80	81	2	1

KET_ECU_81F

C213-2

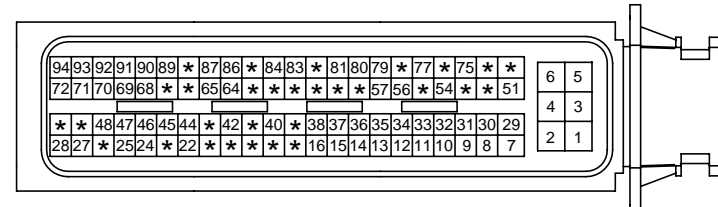

AMP_ECU_94F_B

E02

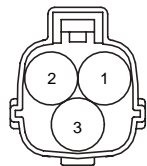

KET_312IWP_03F_B

BLANK

BLANK

BLANK

MFI CONTROL SYSTEM (2.0 GASOLINE) (1)

SD313-1

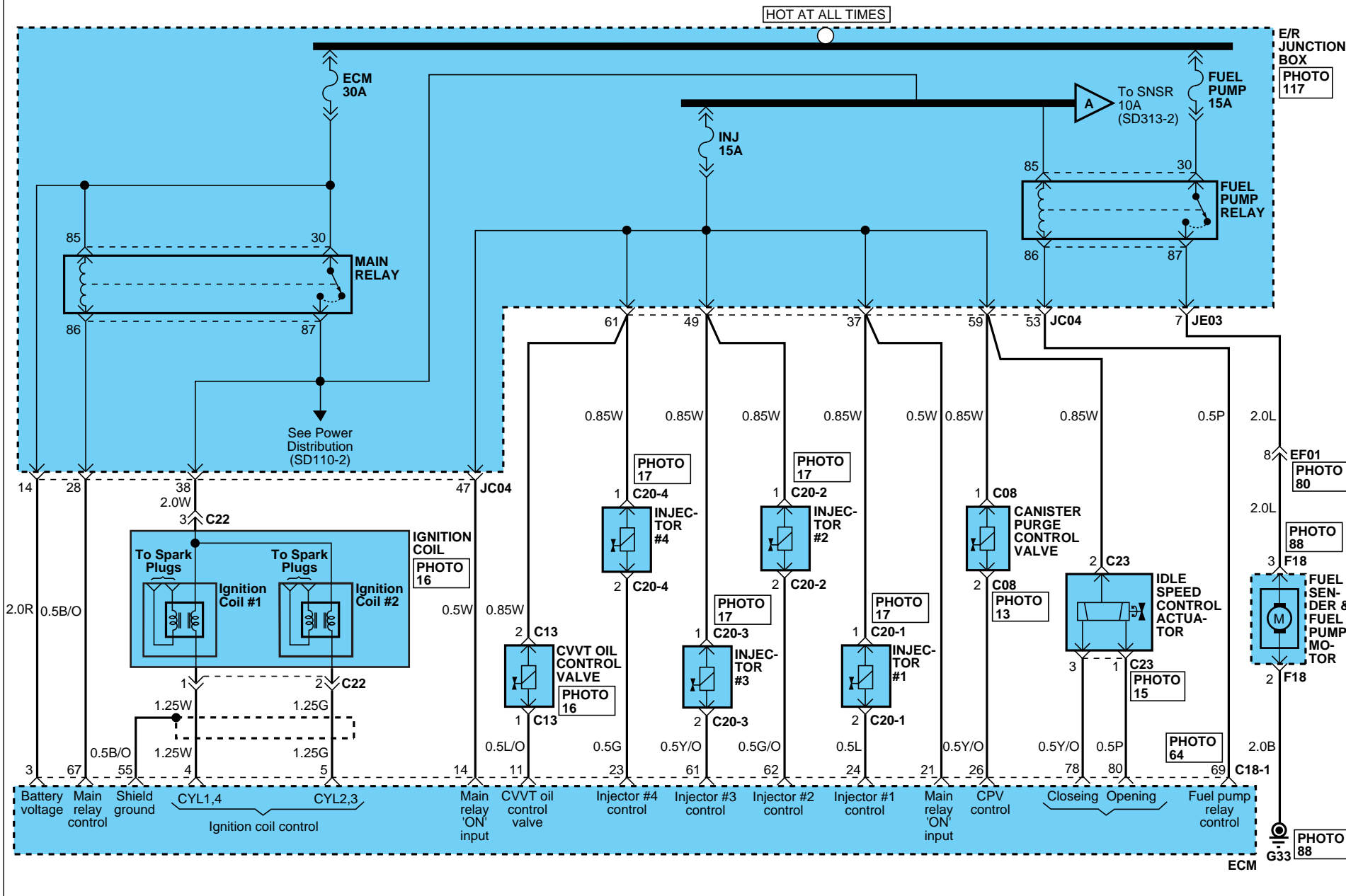

MFI CONTROL SYSTEM

MFI CONTROL SYSTEM (2.0 GASOLINE) (2)

SD313-2

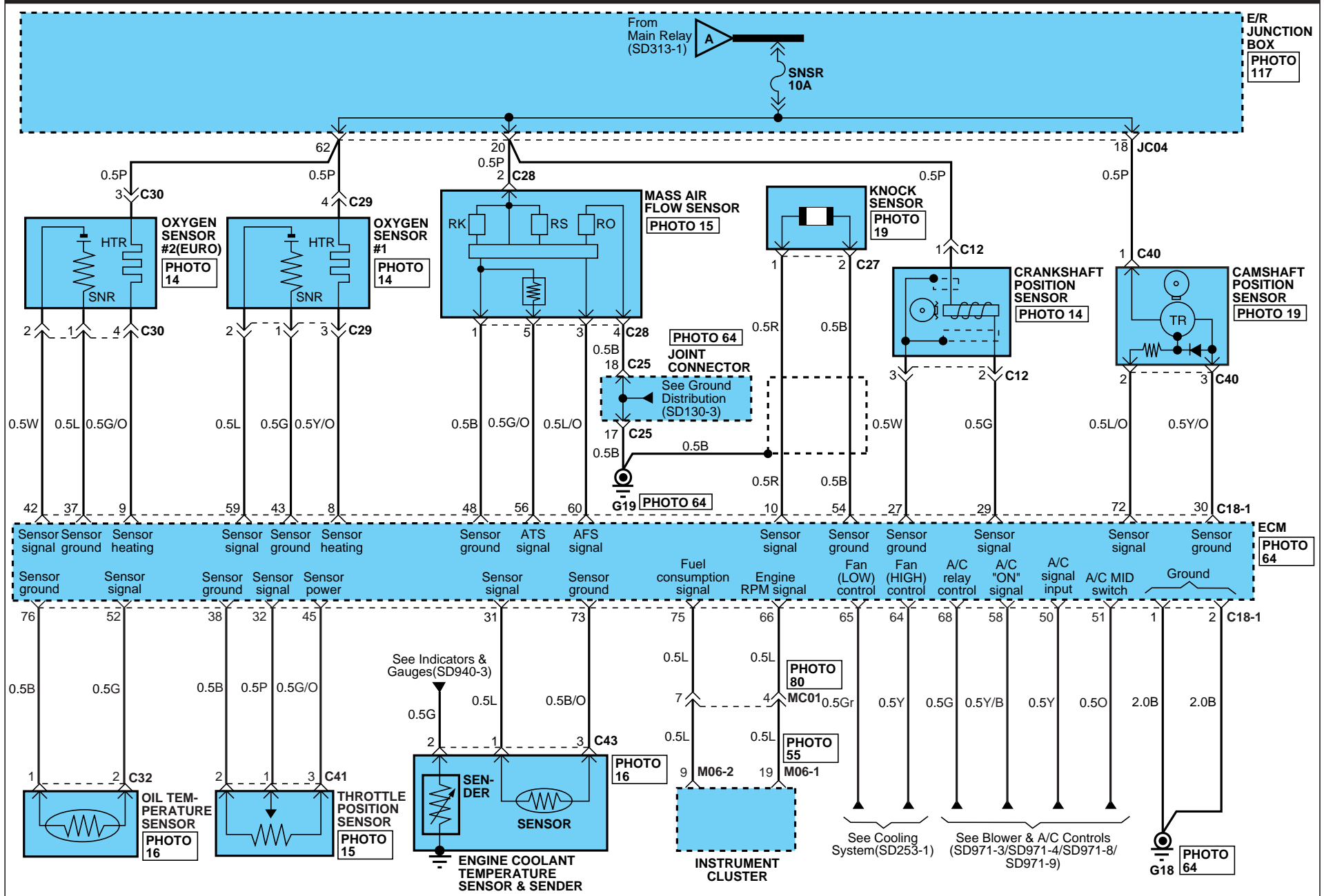

MFI CONTROL SYSTEM

MFI CONTROL SYSTEM (2.0 GASOLINE) (3)

SD313-3

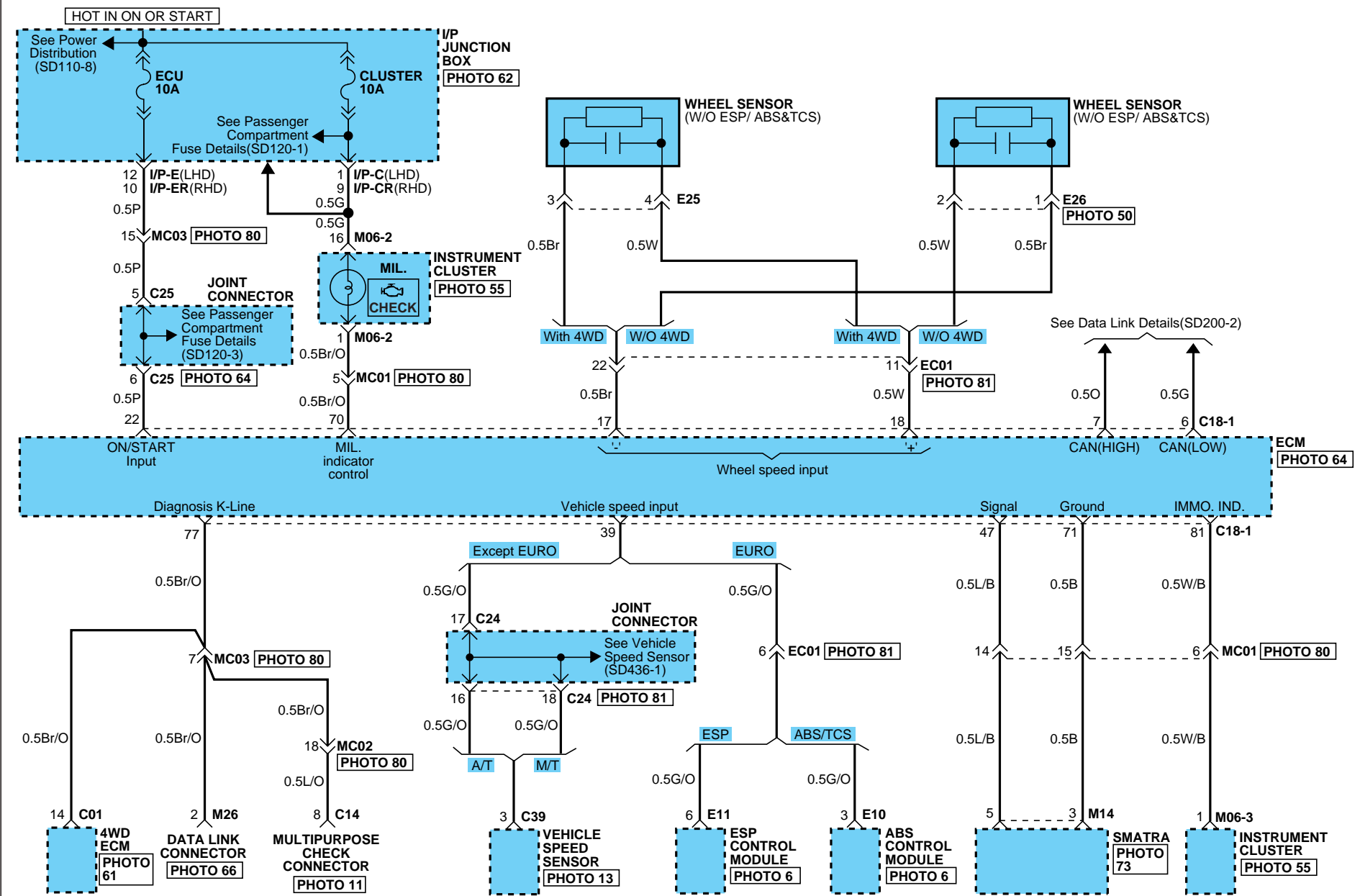

MFI CONTROL SYSTEM

MFI CONTROL SYSTEM (2.0 GASOLINE) (4)

SD313-4

C08

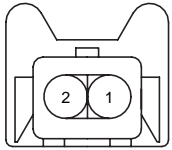

AMP_JPT_02F_B

C12

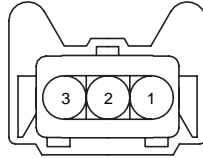

AMP_JPT_03F_GR_R1

C13

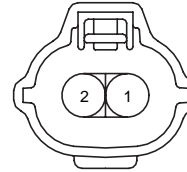

KET_090WP_02F_B_L

C14

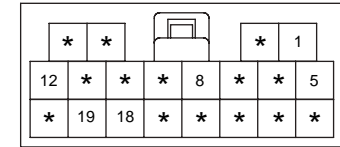

KET_DIAG_20F_B_CLIP

C18-1

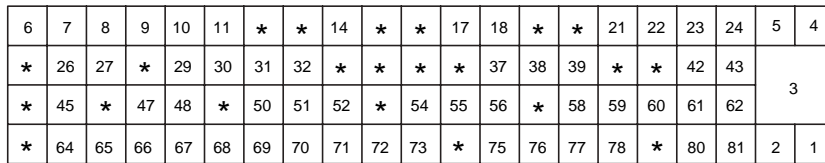

KET_ECU_81F

C20-1

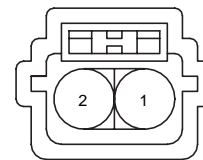

KUM_NDWP_02F_GR

C20-2

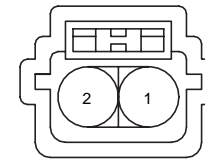

KUM_NDWP_02F_GR

C20-3

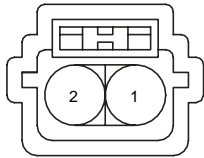

KUM_NDWP_02F_GR

C20-4

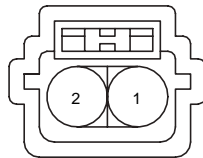

KUM_NDWP_02F_GR

C22

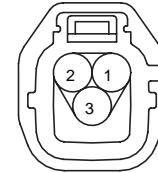

KET_090IWP_03F_B

C23

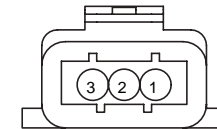

BSH_ISA_03F_GR

C27

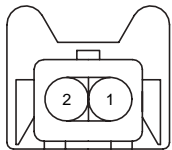

AMP_JPT_02F_B

C28

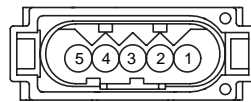

KSP_VDACOEB_05F_B

C29



AMP_EJWP_04F_B

C30

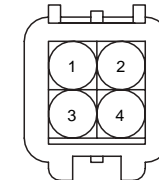

KUM_NMWP_04M_B

C32

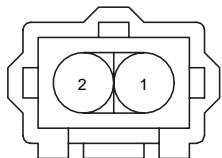

KUM_JFC_02F_B

C39

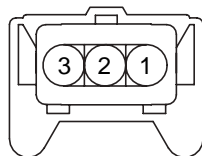

AMP_JPT_03F_B_S1

C40

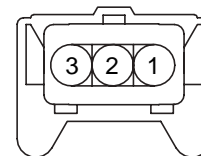

AMP_JPT_03F_B_S1

C41

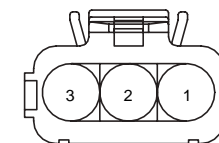

AMP_JPT_03F_B_BOSCH

MFI CONTROL SYSTEM

MFI CONTROL SYSTEM (2.0 GASOLINE) (5)

SD313-5

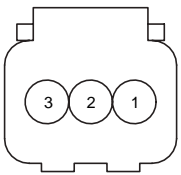
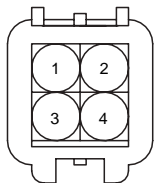
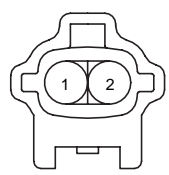
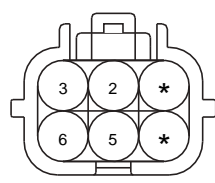
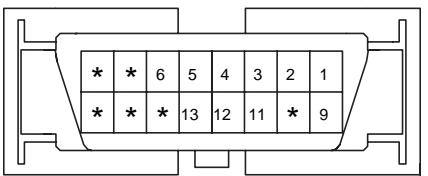
<p style="text-align: center;">C43</p>  <p style="text-align: center;">KUM_WTS_03F_B</p>	<p style="text-align: center;">E25</p>  <p style="text-align: center;">KUM_NMWP_04M_B</p>	<p style="text-align: center;">E26</p>  <p style="text-align: center;">KET_090IWP_02M_B</p>	<p style="text-align: center;">F18</p>  <p style="text-align: center;">KET_SWP_06F_B</p>
<p style="text-align: center;">M26</p>  <p style="text-align: center;">MLX_OBDII_16F_B_SIN</p>	<p style="text-align: center;">BLANK</p>	<p style="text-align: center;">BLANK</p>	<p style="text-align: center;">BLANK</p>

MFI CONTROL SYSTEM

MFI CONTROL SYSTEM (2.0 GASOLINE) (6)

SD313-6

MEMO

MFI CONTROL SYSTEM

MFI CONTROL SYSTEM (2.7 GASOLINE) (1)

SD313-7

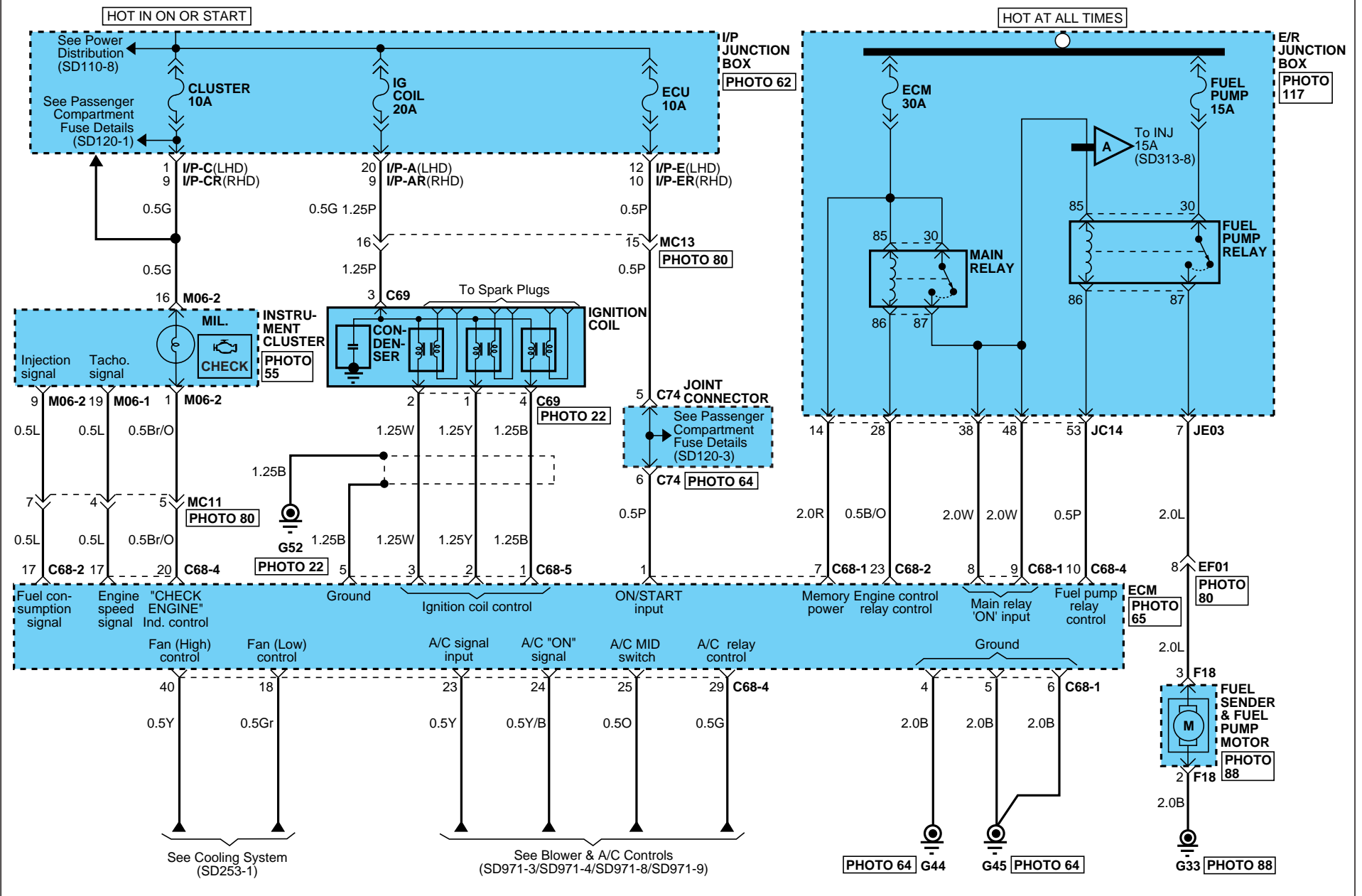

MFI CONTROL SYSTEM

MFI CONTROL SYSTEM (2.7 GASOLINE) (2)

SD313-8

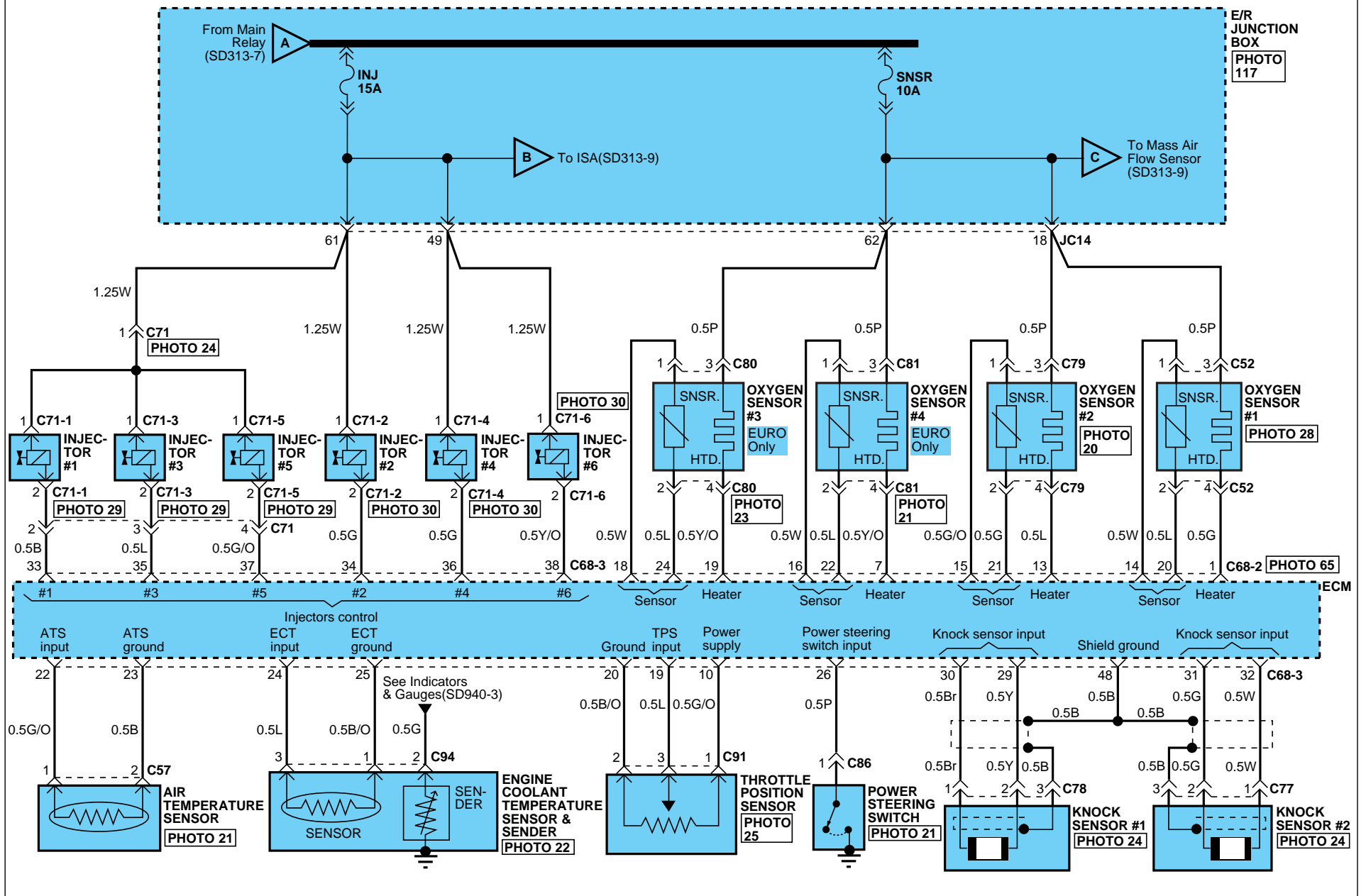

MFI CONTROL SYSTEM

MFI CONTROL SYSTEM (2.7 GASOLINE) (3)

SD313-9

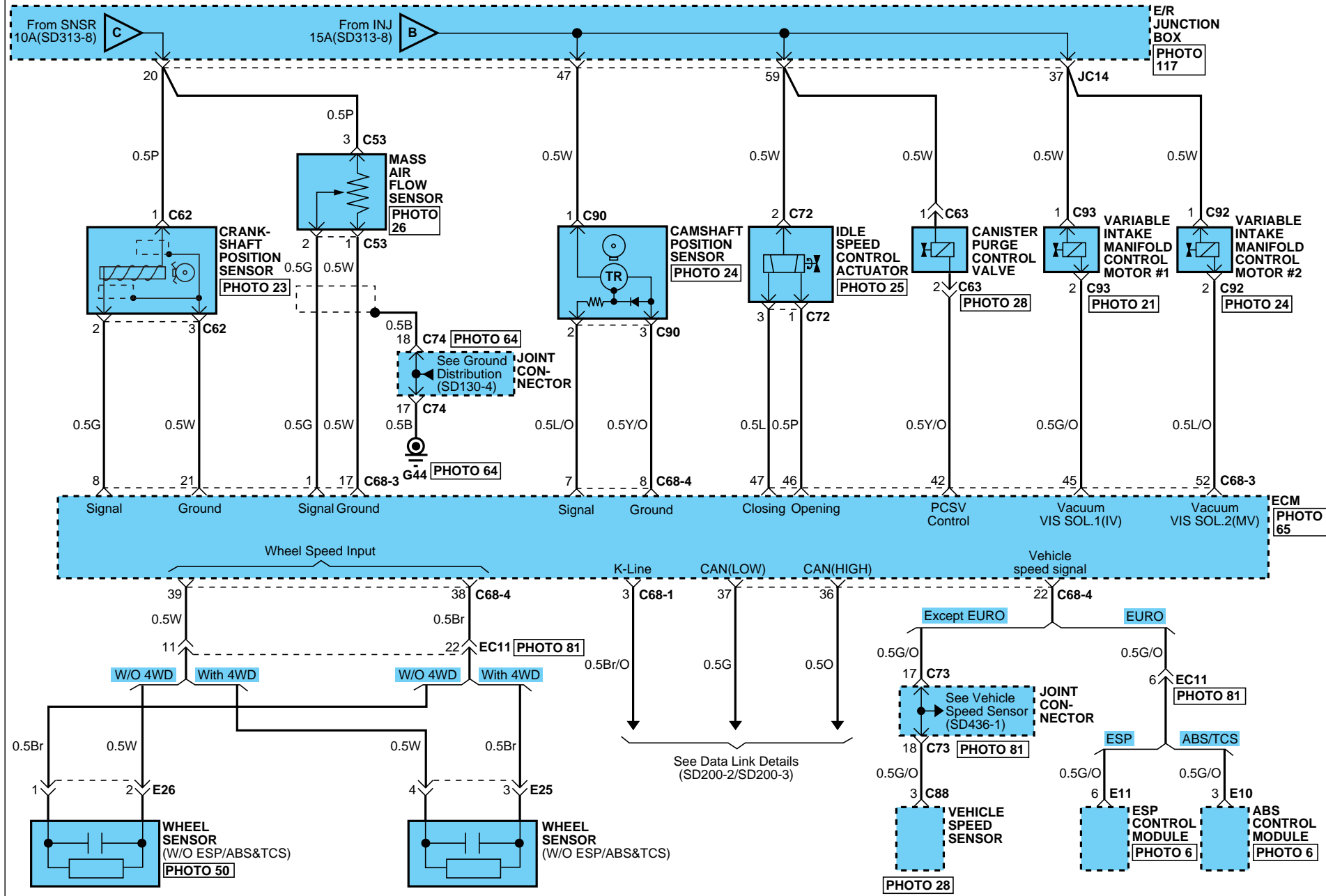

MFI CONTROL SYSTEM

MFI CONTROL SYSTEM (2.7 GASOLINE) (4)

SD313-10

C52/C79/C80/C81

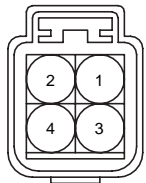

KUM_NMWP_04F_Gr

C53

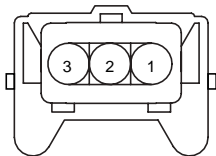

AMP_JPT_03F_B_CLIP

C57

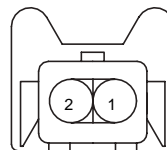

AMP_JPT_02F_B

C62

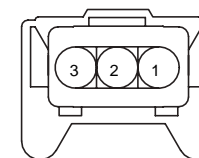

AMP_JPT_03F_B_S2

C63

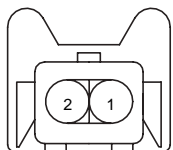

AMP_JPT_02F_B

C68-1

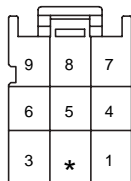

AMP_ECU_09F_134P

C68-2

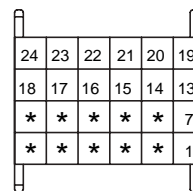

AMP_ECU_24F_B_134P

C68-4

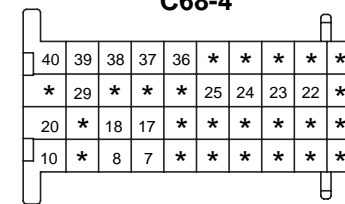

AMP_ECU_40F_B_134P

C68-3

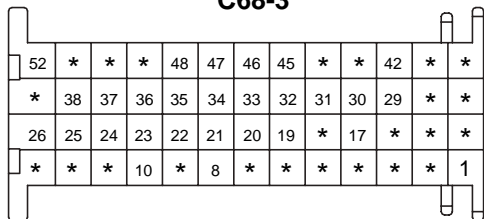

AMP_ECU_52F_B_134P

C68-5



AMP_ECU_09F_134P

C69

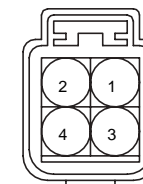

KUM_NMWP_04F_B

C71

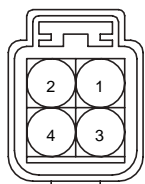

KUM_NMWP_04F_B

C71-1,3,5

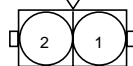

CR02F016

C71-2,4,6

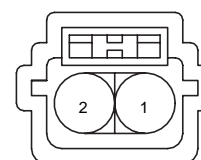

KUM_NDWP_02F_Gr

C72

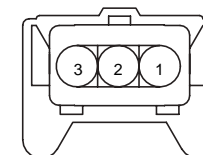

AMP_JPT_03F_B_S1

C77

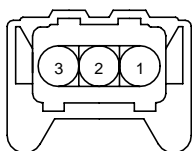

AMP_JPT_03F_B_S2

C78

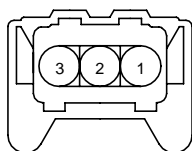

AMP_JPT_03F_Gr_R2

C86



MOLEX_35012-0101

C88

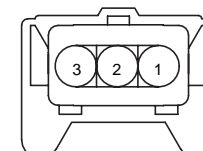

AMP_JPT_03F_B_S1

MFI CONTROL SYSTEM

MFI CONTROL SYSTEM (2.7 GASOLINE) (5)

SD313-11

C90

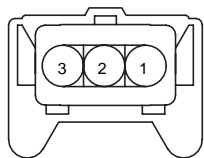

AMP_JPT_03F_B_S1

C91

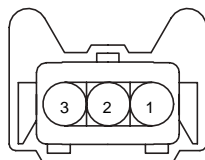

AMP_JPT_03F_Gr_R1

C92

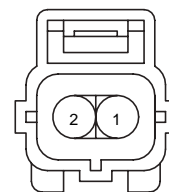

AMP_EJWP_02F_B

C93

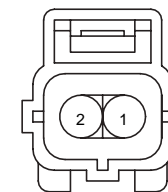

AMP_EJWP_02F_B

C94

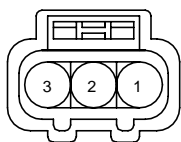

KUM_62Z_03F_B_WTS

E25

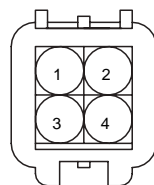

KUM_NMWP_04M_B

E26

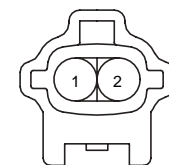

KET_090IWP_02M_B

F18

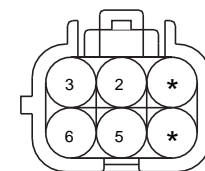

KET_SWP_06F_B

MFI CONTROL SYSTEM

MFI CONTROL SYSTEM (2.7 GASOLINE) (6)

SD313-12

MEMO

MFI CONTROL SYSTEM (DIESEL EURO-III) (1)

SD313-13

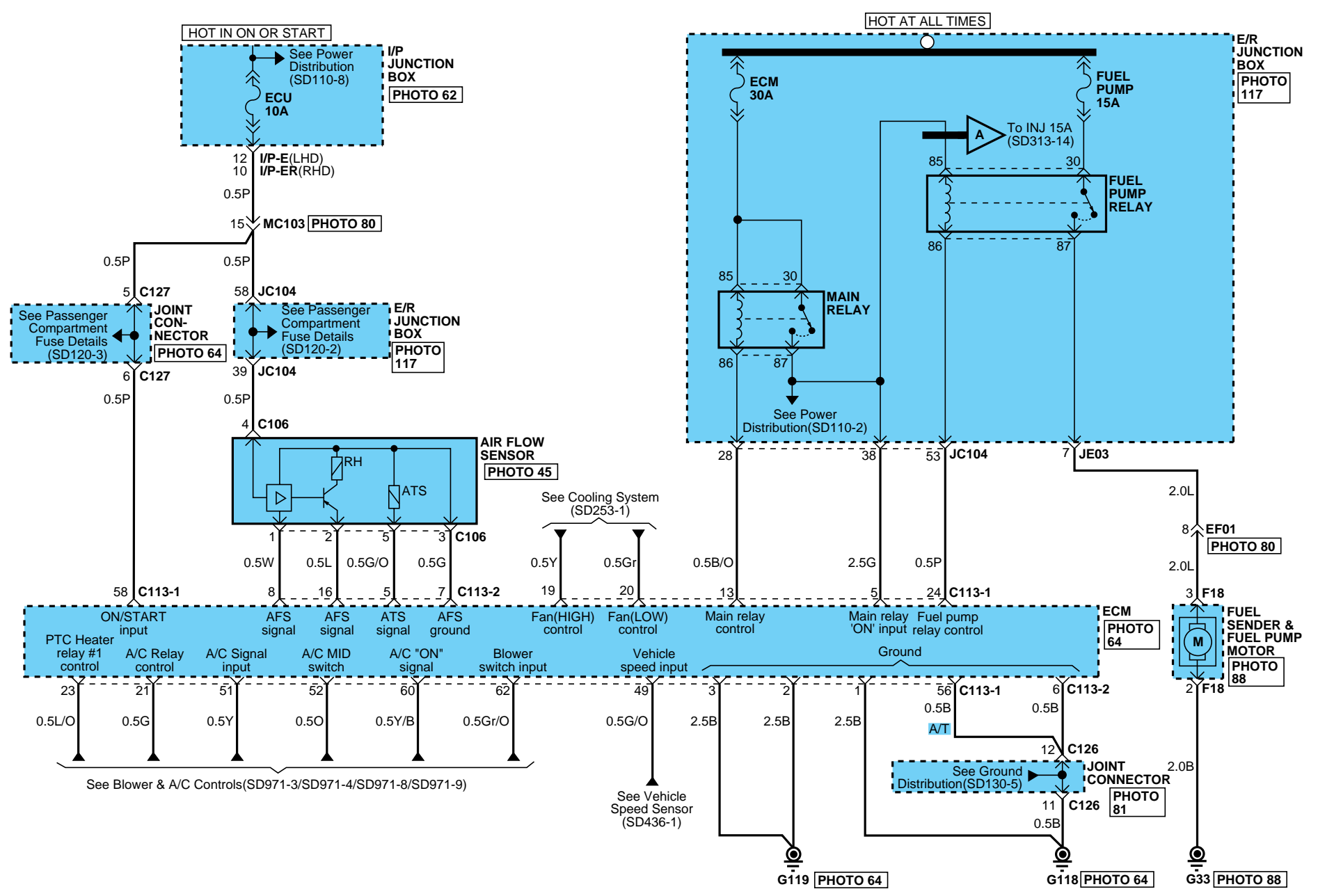

MFI CONTROL SYSTEM

MFI CONTROL SYSTEM (DIESEL EURO-III) (2)

SD313-14

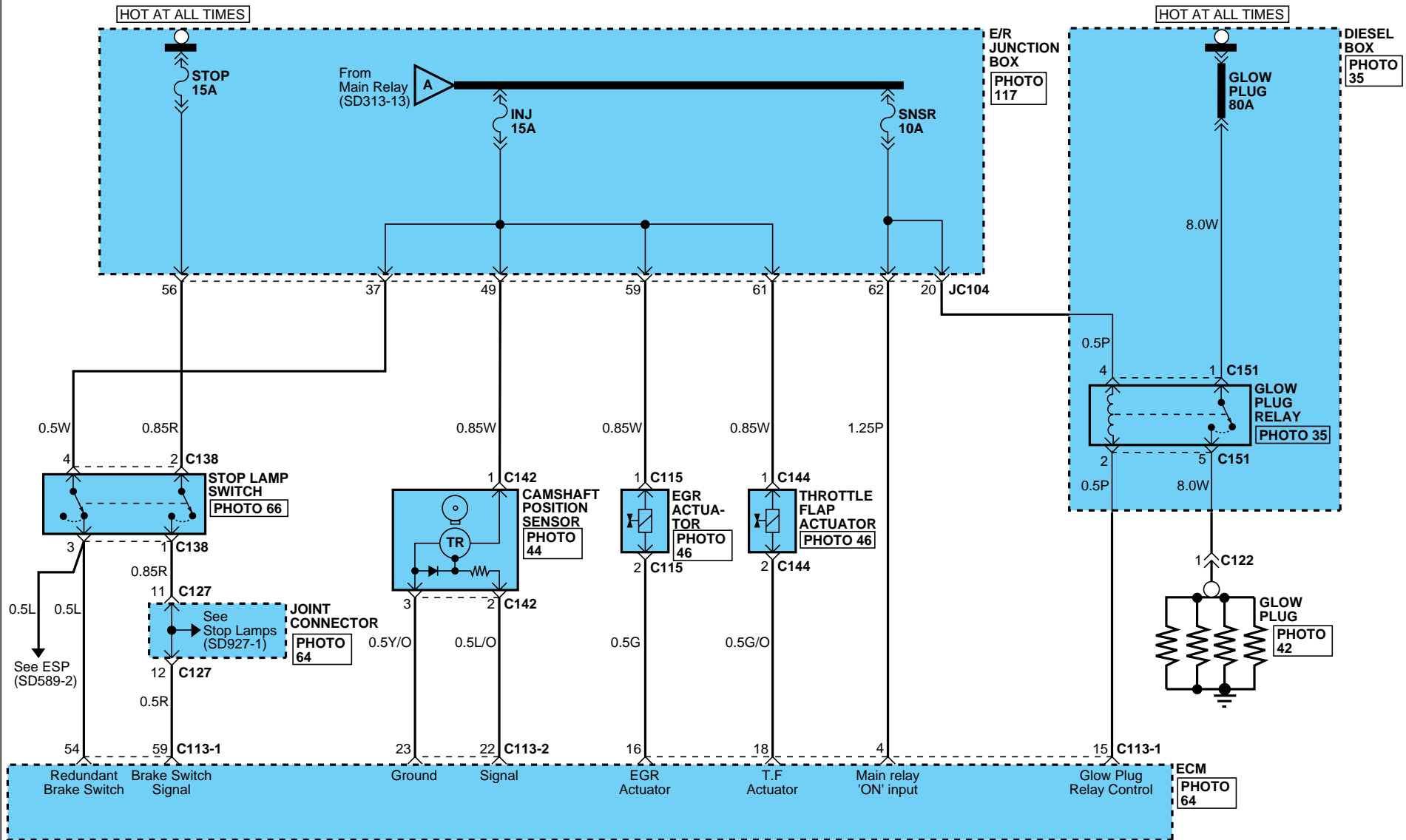

MFI CONTROL SYSTEM

MFI CONTROL SYSTEM (DIESEL EURO-III) (3)

SD313-15

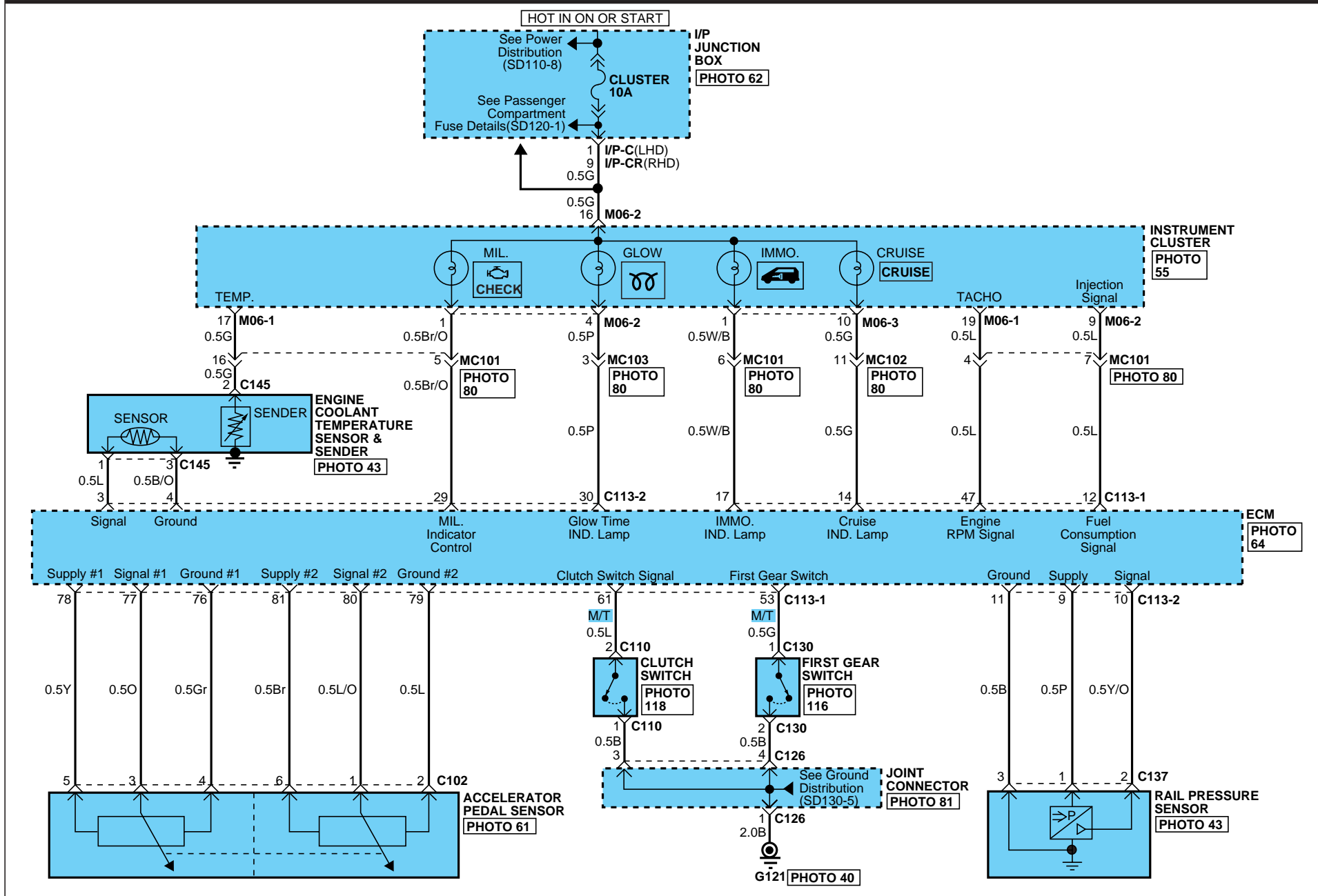

MFI CONTROL SYSTEM

MFI CONTROL SYSTEM (DIESEL EURO-III) (4)

SD313-16

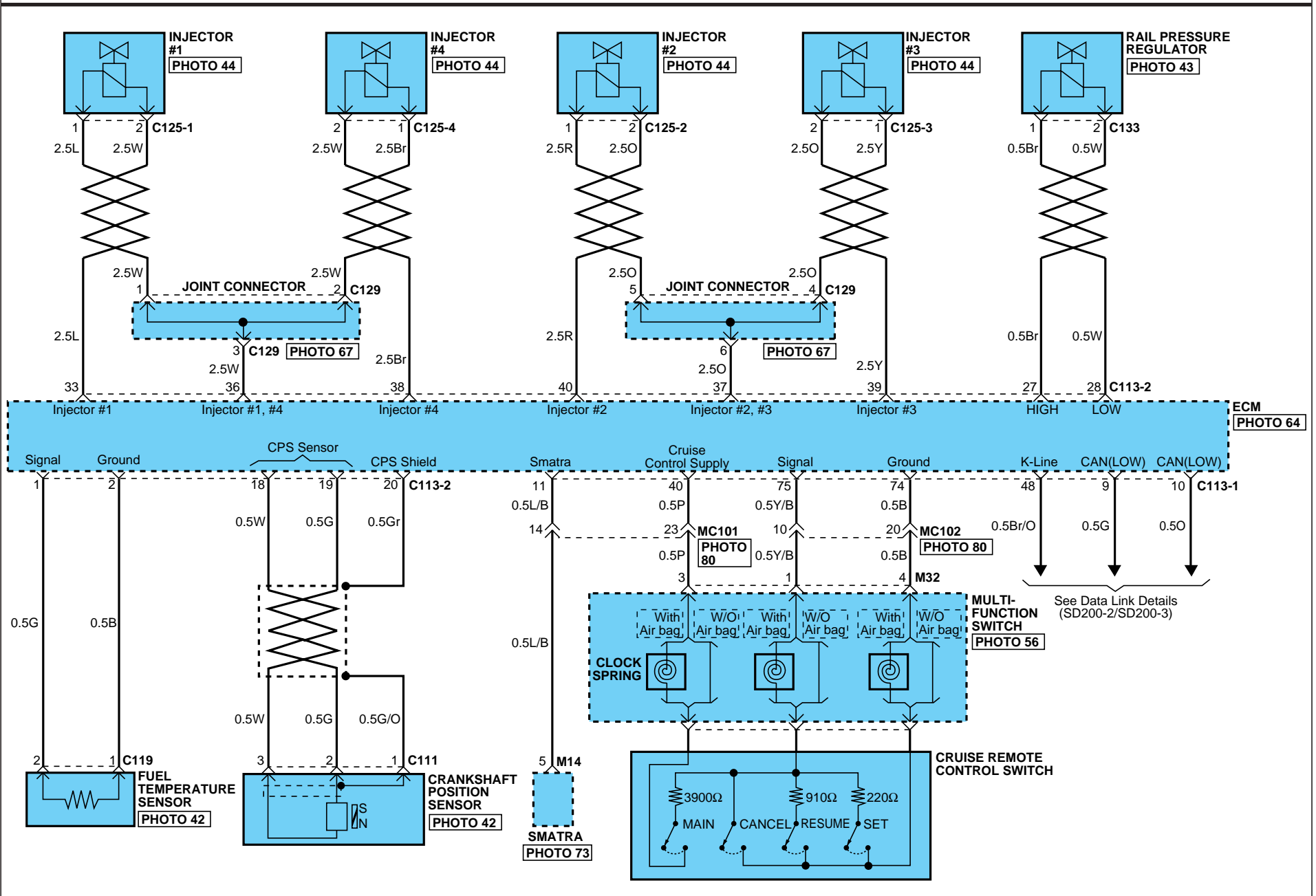

MFI CONTROL SYSTEM

MFI CONTROL SYSTEM (DIESEL EURO-III) (5)

SD313-17

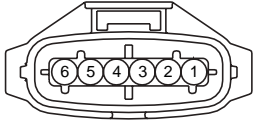
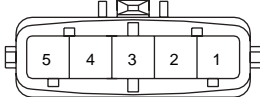
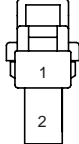
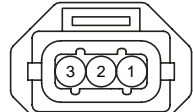
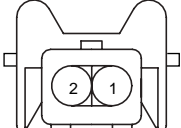
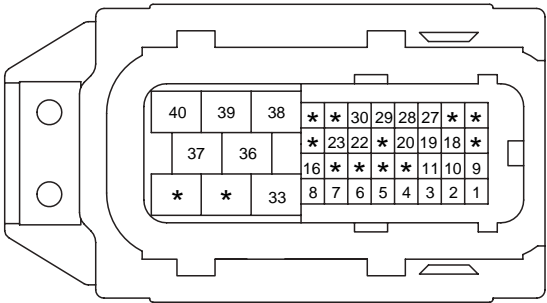
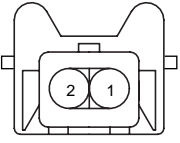
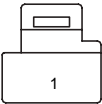
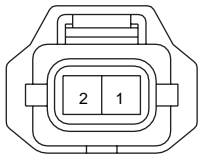
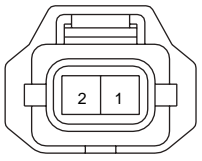
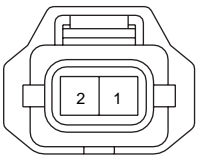
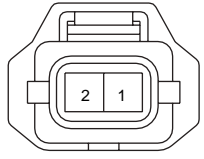
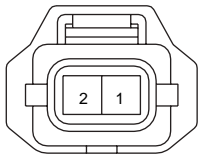
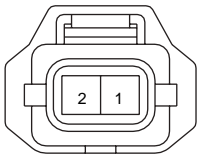
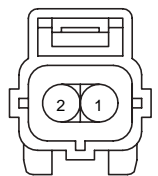
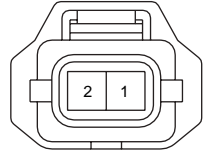
<p>C102</p>  <p style="text-align: right; font-size: small;">AMP_6F</p>	<p>C106</p>  <p style="text-align: right; font-size: small;">BSH_EMS_05F_B_1</p>	<p>C110</p>  <p style="text-align: right; font-size: small;">KET_250DL_02F_W</p>	<p>C111</p>  <p style="text-align: right; font-size: small;">BSH_EMS_03F_B_1</p>																																																																																		
<p>C115</p>  <p style="text-align: right; font-size: small;">AMP_JPT_02F_B_CLIP</p>	<p>C113-1</p> <table border="1" style="margin: auto; border-collapse: collapse; font-size: x-small;"> <tr><td>*</td><td>*</td><td>*</td><td>9</td><td>10</td><td>11</td><td>12</td><td>13</td><td>14</td><td>15</td><td>16</td><td>17</td><td>18</td><td>19</td><td>20</td><td>21</td><td>*</td><td>23</td><td>24</td><td>5</td><td>4</td></tr> <tr><td>*</td><td>*</td><td>*</td><td>*</td><td>*</td><td>*</td><td>*</td><td>*</td><td>*</td><td>*</td><td>*</td><td>*</td><td>*</td><td>*</td><td>*</td><td>40</td><td>*</td><td>*</td><td>*</td><td colspan="2" rowspan="2">3</td></tr> <tr><td>*</td><td>*</td><td>*</td><td>47</td><td>48</td><td>49</td><td>*</td><td>51</td><td>52</td><td>53</td><td>54</td><td>*</td><td>56</td><td>*</td><td>58</td><td>59</td><td>60</td><td>61</td><td>62</td></tr> <tr><td>*</td><td>*</td><td>*</td><td>*</td><td>*</td><td>*</td><td>*</td><td>*</td><td>*</td><td>*</td><td>*</td><td>74</td><td>75</td><td>76</td><td>77</td><td>78</td><td>79</td><td>80</td><td>81</td><td>2</td><td>1</td></tr> </table> <p style="text-align: right; font-size: small;">KET_ECU_81F</p>		*	*	*	9	10	11	12	13	14	15	16	17	18	19	20	21	*	23	24	5	4	*	*	*	*	*	*	*	*	*	*	*	*	*	*	*	40	*	*	*	3		*	*	*	47	48	49	*	51	52	53	54	*	56	*	58	59	60	61	62	*	*	*	*	*	*	*	*	*	*	*	74	75	76	77	78	79	80	81	2	1	<p>BLANK</p>
*	*	*	9	10	11	12	13	14	15	16	17	18	19	20	21	*	23	24	5	4																																																																	
*	*	*	*	*	*	*	*	*	*	*	*	*	*	*	40	*	*	*	3																																																																		
*	*	*	47	48	49	*	51	52	53	54	*	56	*	58	59	60	61	62																																																																			
*	*	*	*	*	*	*	*	*	*	*	74	75	76	77	78	79	80	81	2	1																																																																	
<p>C113-2</p>  <p style="text-align: right; font-size: small;">KET_ECU_40F_B</p>		<p>C119</p>  <p style="text-align: right; font-size: small;">AMP_JPT_02F_B_CLIP</p>	<p>C122</p>  <p style="text-align: right; font-size: small;">KET_58L_01F_B</p>																																																																																		
<p>C125-3</p>  <p style="text-align: right; font-size: small;">BSH_INJ_02F_B</p>		<p>C125-4</p>  <p style="text-align: right; font-size: small;">BSH_INJ_02F_B</p>	<p>C125-1</p>  <p style="text-align: right; font-size: small;">BSH_INJ_02F_B</p>	<p>C125-2</p>  <p style="text-align: right; font-size: small;">BSH_INJ_02F_B</p>																																																																																	
<p>C125-3</p>  <p style="text-align: right; font-size: small;">BSH_INJ_02F_B</p>		<p>C125-4</p>  <p style="text-align: right; font-size: small;">BSH_INJ_02F_B</p>	<p>C130</p>  <p style="text-align: right; font-size: small;">AMP_EJWP_02F_B</p>	<p>C133</p>  <p style="text-align: right; font-size: small;">BSH_INJ_02F_B</p>																																																																																	

MFI CONTROL SYSTEM

MFI CONTROL SYSTEM (DIESEL EURO-III) (6)

SD313-18

C137



BSH_EMS_03F_B_2

C138

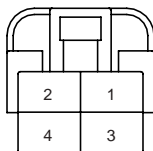

KET_250DL_04F_W

C142

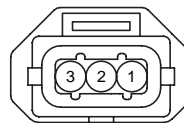

BSH_EMS_03F_B_1

C144

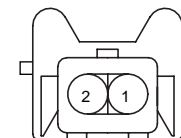

AMP_JPT_02F_B_CLIP

C145

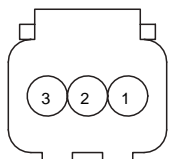

KUM_WTS_03F_B

C151

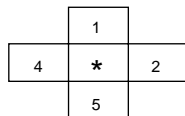

CR05F019

F18

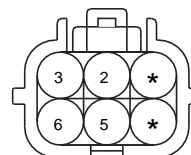

KET_SWP_06F_B

M32

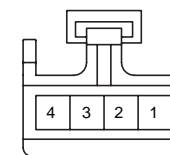

FUR_FA_04F_B_AB

MFI CONTROL SYSTEM

MFI CONTROL SYSTEM (DIESEL EURO-IV) (1)

SD313-19

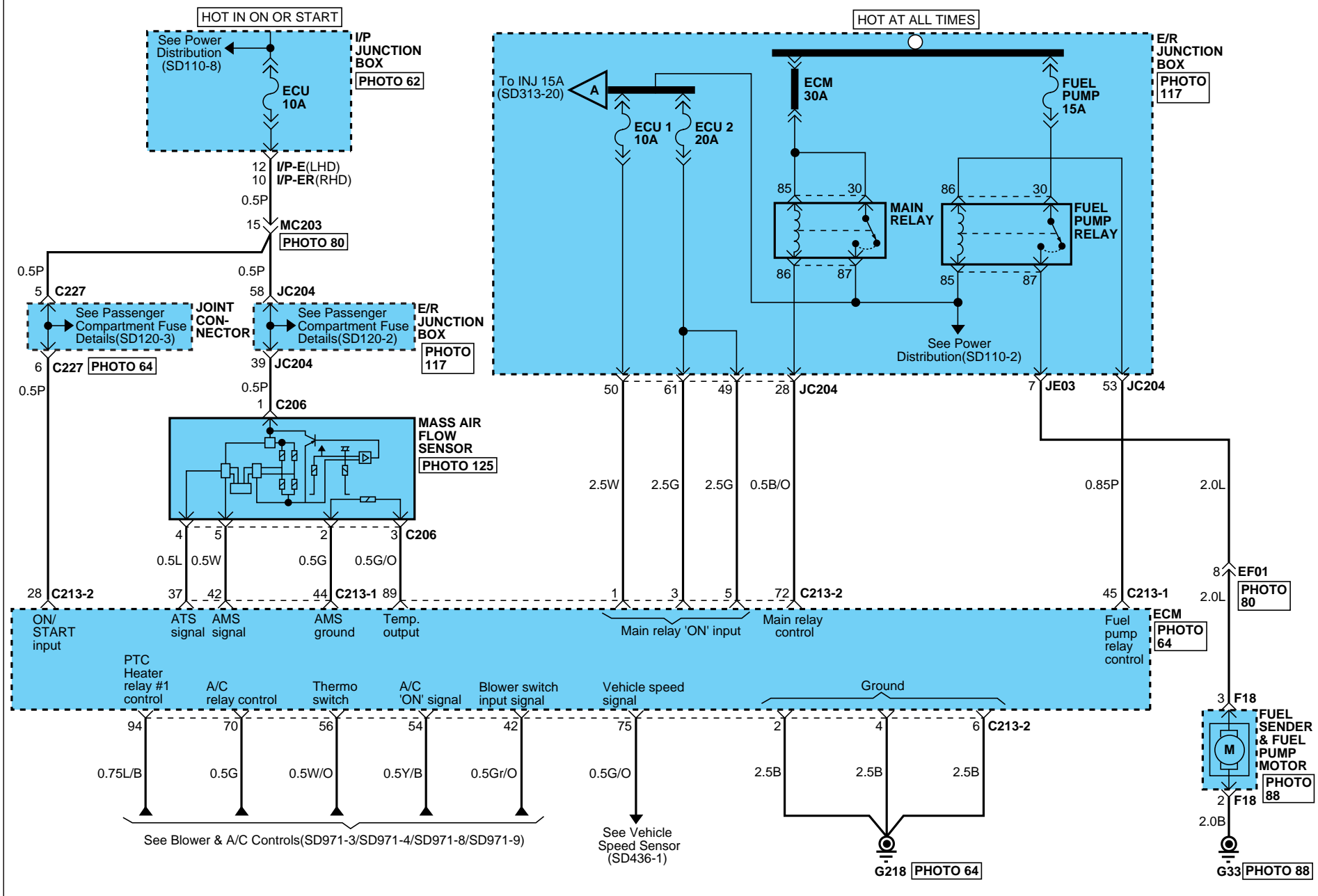

MFI CONTROL SYSTEM

MFI CONTROL SYSTEM (DIESEL EURO-IV) (2)

SD313-20

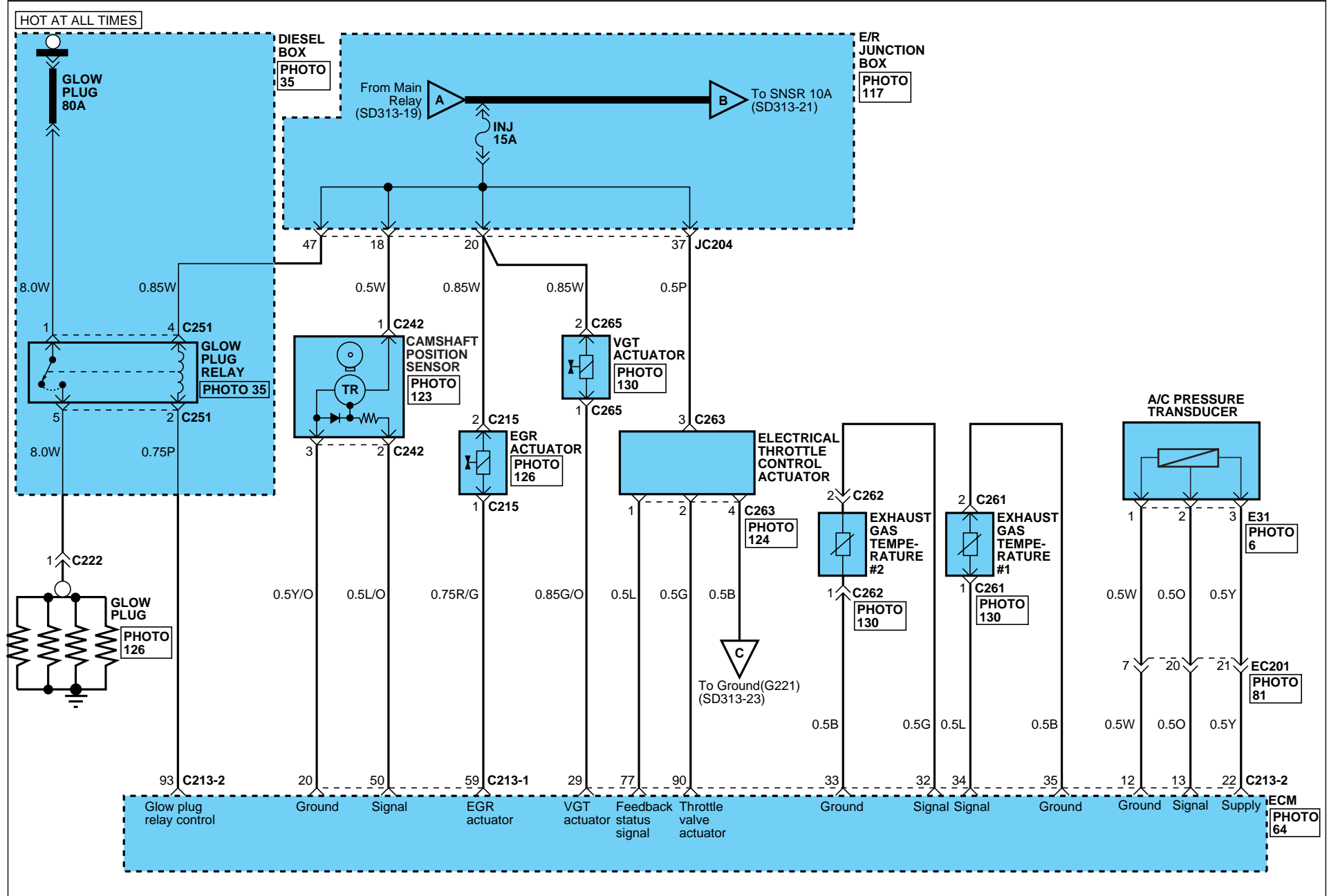

MFI CONTROL SYSTEM

MFI CONTROL SYSTEM (DIESEL EURO-IV) (3)

SD313-21

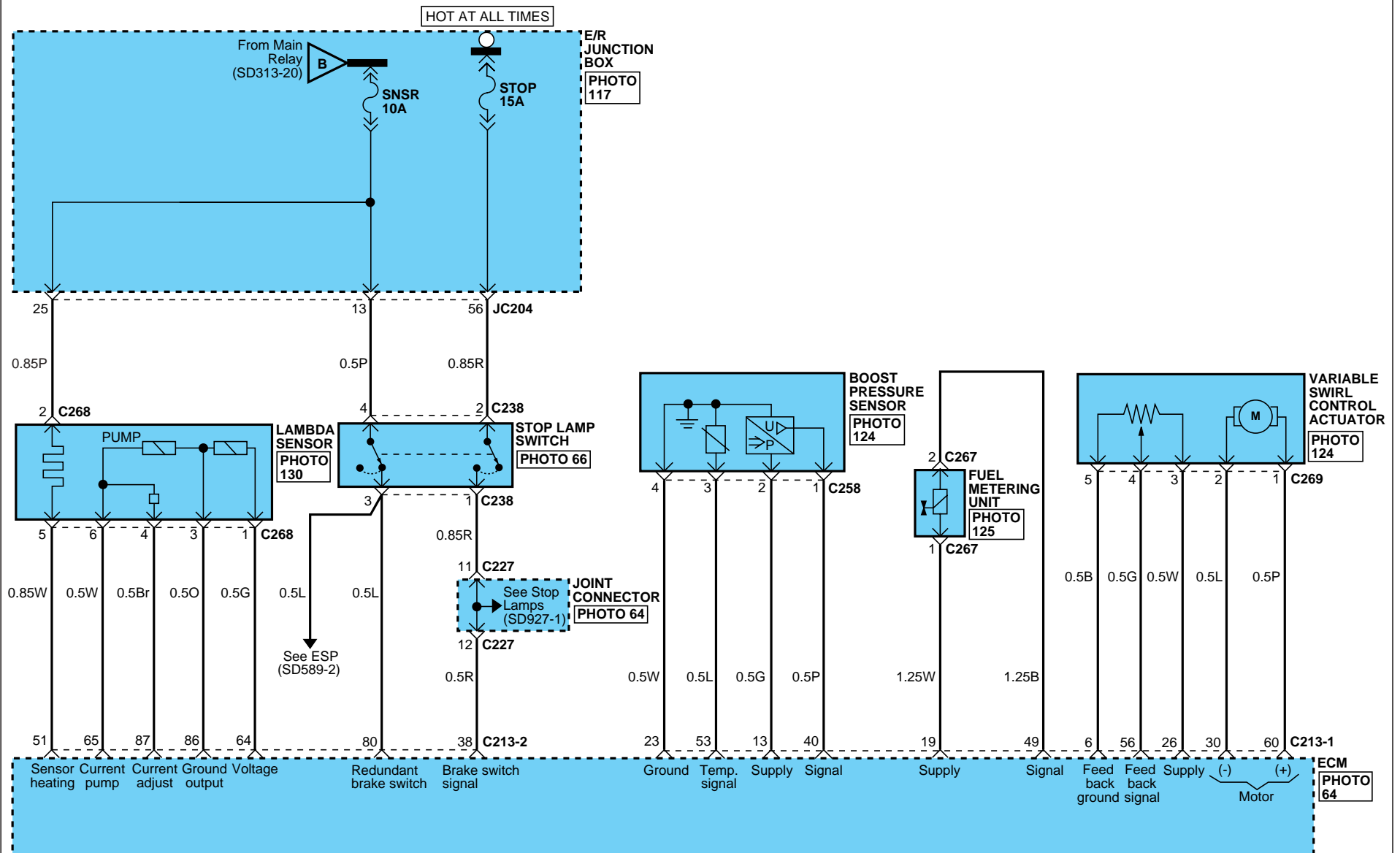

MFI CONTROL SYSTEM

MFI CONTROL SYSTEM (DIESEL EURO-IV) (4)

SD313-22

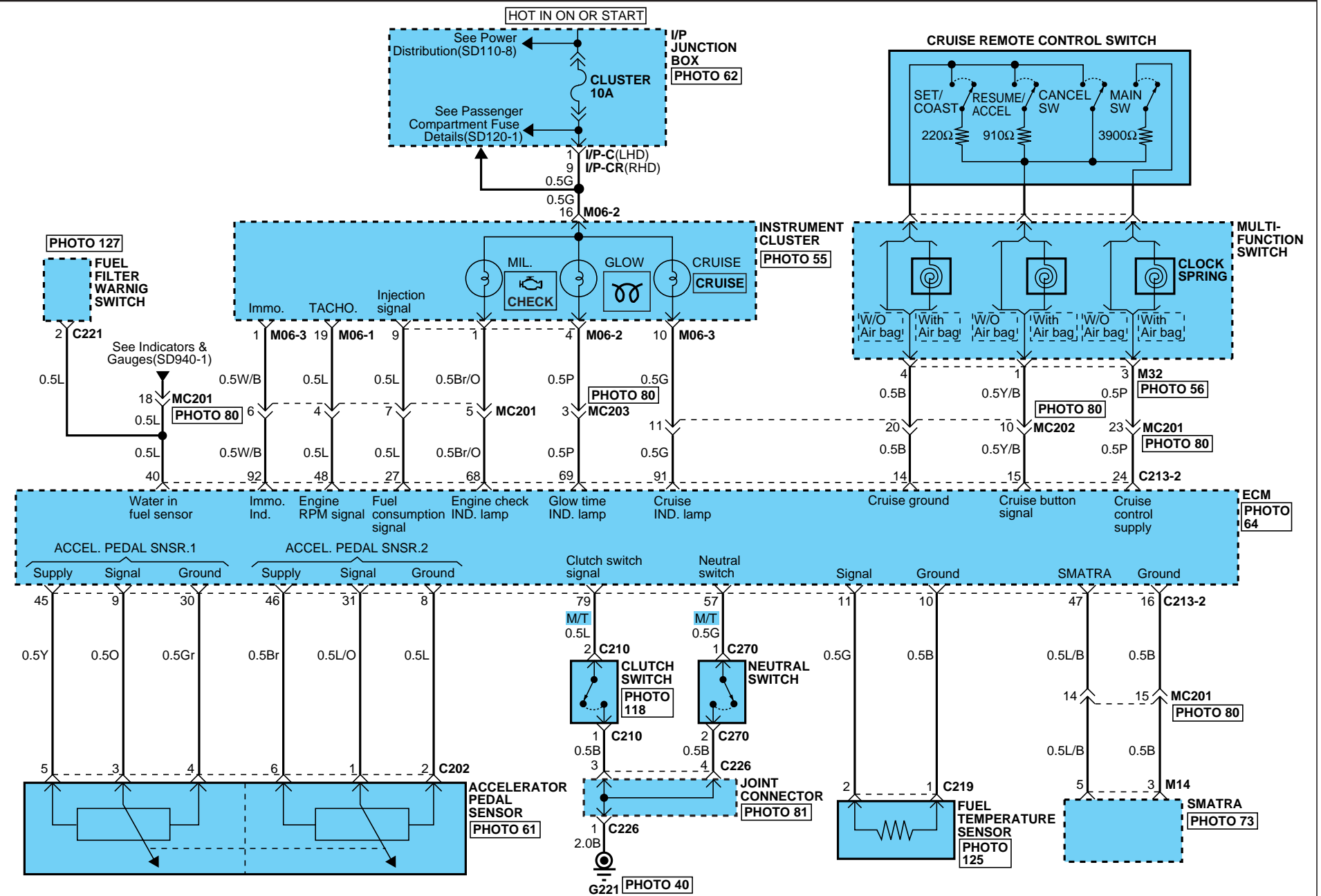

MFI CONTROL SYSTEM

MFI CONTROL SYSTEM (DIESEL EURO-IV) (5)



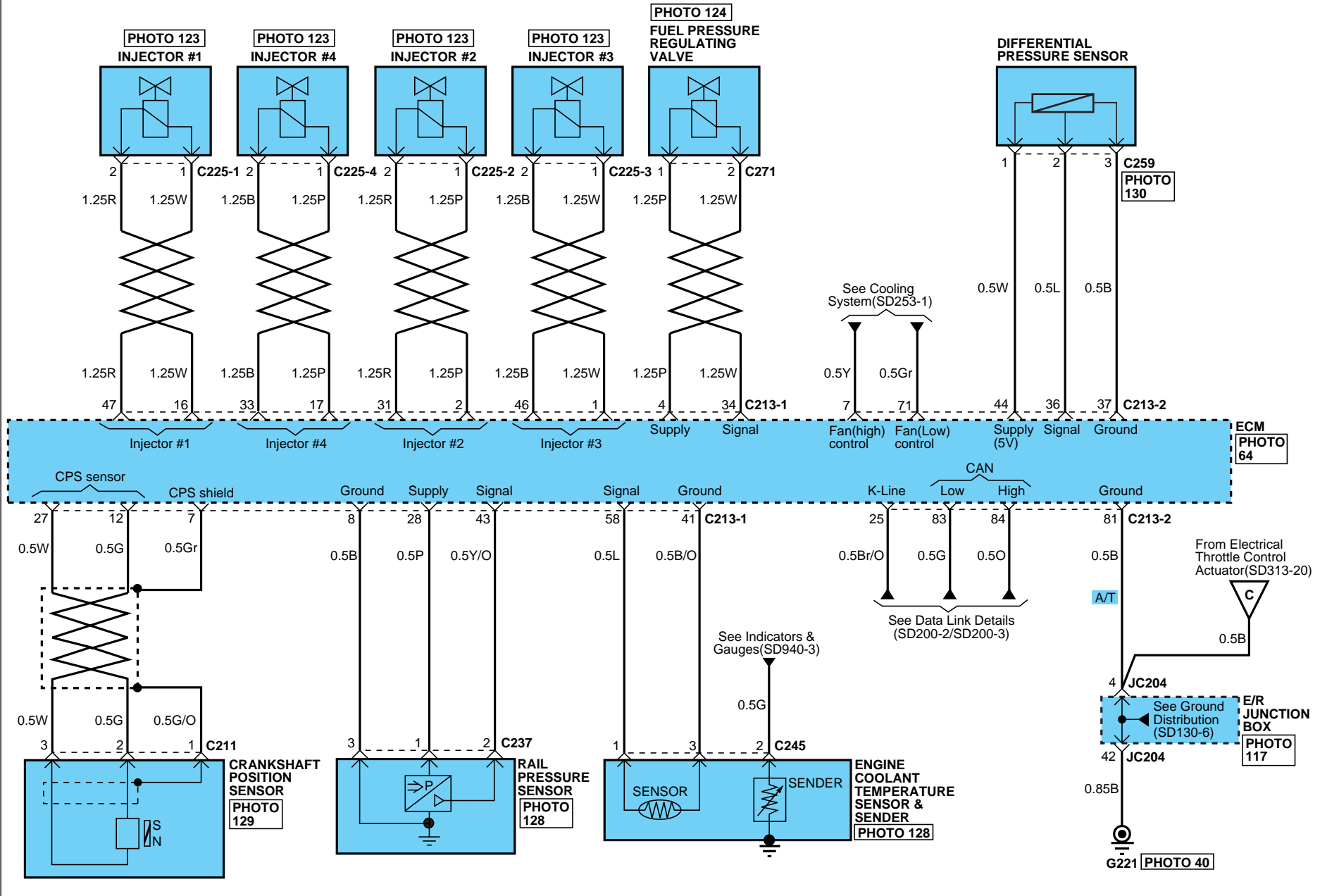

SD313-23

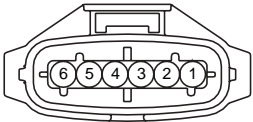
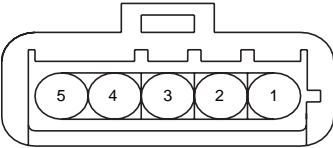
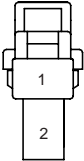
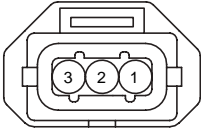
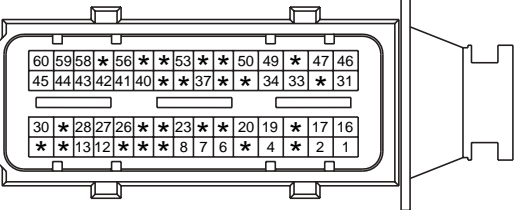
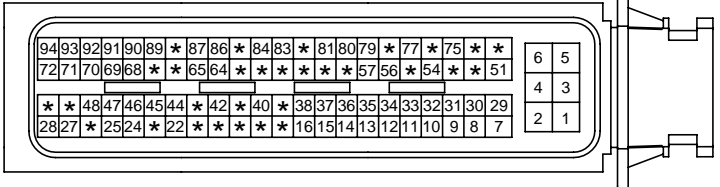
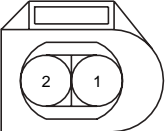
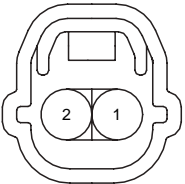
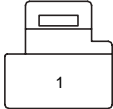
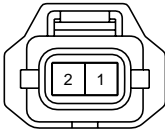

MFI CONTROL SYSTEM

MFI CONTROL SYSTEM (DIESEL EURO-IV) (6)

SD313-24

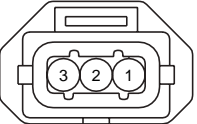
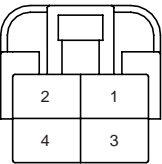
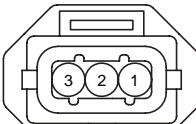
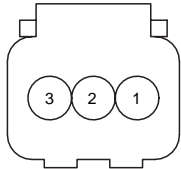
<p>C202</p>  <p>AMP_06F</p>	<p>C206</p>  <p>HIRSCHMANN_05F_B</p>	<p>C210</p>  <p>KET_250DL_02F_W</p>	<p>C211</p>  <p>BSH_EMS_03F_B_1</p>
<p>C213-1</p>  <p>AMP_ECU_60F_B</p>		<p>C213-2</p>  <p>AMP_ECU_94F_B</p>	
<p>C215</p>  <p>KST_SENSOR_02F_B</p>	<p>C219</p>  <p>KET_280WP_02F_B_1</p>	<p>C222</p>  <p>KET_58L_01_W</p>	<p>C225-1</p>  <p>BSH_INJ_02F_B</p>
<p>C225-2</p>  <p>BSH_INJ_02F_B</p>	<p>C225-3</p>  <p>BSH_INJ_02F_B</p>	<p>C225-4</p>  <p>BSH_INJ_02F_B</p>	<p>BLANK</p>
<p>C237</p>  <p>BSH_EMS_03F_B_2</p>	<p>C238</p>  <p>KET_250DL_04F_W</p>	<p>C242</p>  <p>BSH_EMS_03F_B_1</p>	<p>C245</p>  <p>KUM_WTS_03F_B</p>

MFI CONTROL SYSTEM

MFI CONTROL SYSTEM (DIESEL EURO-IV) (7)

SD313-25

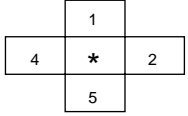
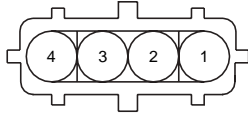
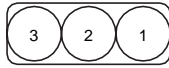
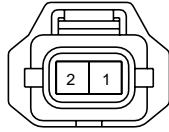
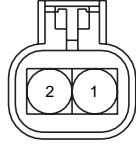
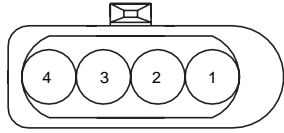
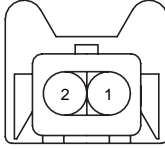
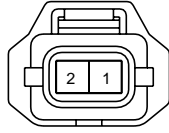
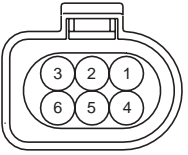
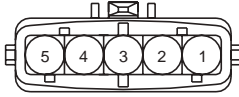
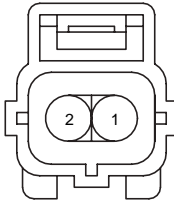
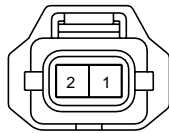
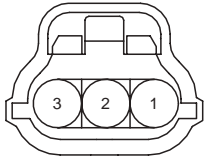
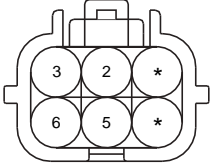
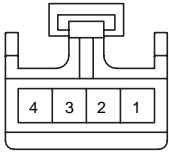
<p>C251</p>  <p>CR05F019</p>	<p>C258</p>  <p>BSH_SENSOR_04F_B_NF</p>	<p>C259</p>  <p>SUM_SENSOR_03F_B</p>	<p>C261</p>  <p>BSH_INJ_02F_B</p>
<p>C262</p>  <p>SUM_SENSOR_02M_B</p>	<p>C263</p>  <p>FBP_NFDSL_04F_N</p>	<p>C265</p>  <p>AMP_JPT_02F_B_CLIP</p>	<p>C267</p>  <p>BSH_INJ_02F_B</p>
<p>C268</p>  <p>BSH_SENSOR_06F_B_NF</p>	<p>C269</p>  <p>BSH_EMS_05F_B_1</p>	<p>C270</p>  <p>AMP_EJWP_02F_B</p>	<p>C271</p>  <p>BSH_INJ_02F_B</p>
<p>E31</p>  <p>KET_040WP_03F_B</p>	<p>F18</p>  <p>KET_SWP_06F_B</p>	<p>M32</p>  <p>FUR_FA_04F_N_AB</p>	<p>BLANK</p>

MFI CONTROL SYSTEM

MFI CONTROL SYSTEM (DIESEL EURO-IV) (8)

SD313-26

MEMO

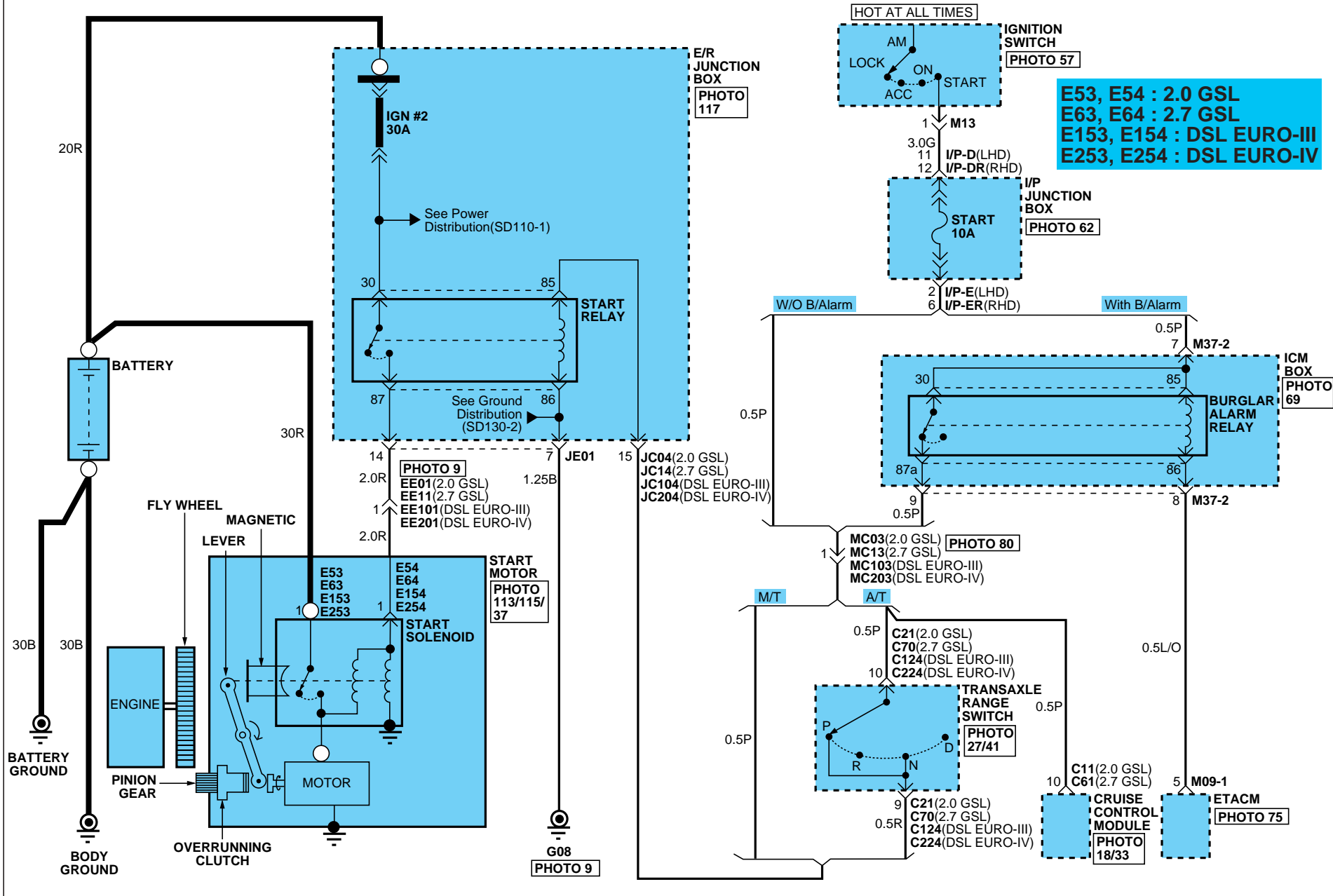

STARTING SYSTEM (1)

SD360-1

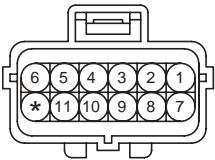

STARTING SYSTEM

STARTING SYSTEM (2) SD360-2

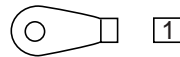
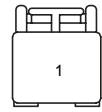
<p>C11/C61</p>  <p>AMP_EJWP_12F_B</p>	<p>C21/C70/C124/C224</p>  <p>KET_SSD_10F_B_A</p>	<p>E53/E63/E153/E253</p>  <p>CR01F052</p>	<p>E54/E64</p>  <p>KET_250WP_01F_B</p>
---	--	---	--

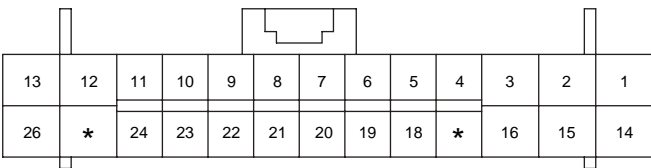
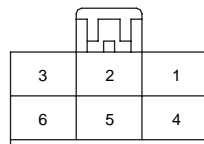
<p>E154/E254</p>  <p>KET_250WP_01F_B</p>	<p>M09-1</p>  <p>AMP_0407_26F_W_HD</p>	<p>M13</p>  <p>KUM_DSD_06F_B</p>
--	---	--

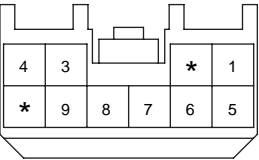
<p>M37-2</p>  <p>AMP_090III_10F_W</p>	<p>BLANK</p>	<p>BLANK</p>	<p>BLANK</p>
---	---------------------	---------------------	---------------------

FUEL FILTER HEATING SYSTEM (DIESEL) (1)

SD361-1

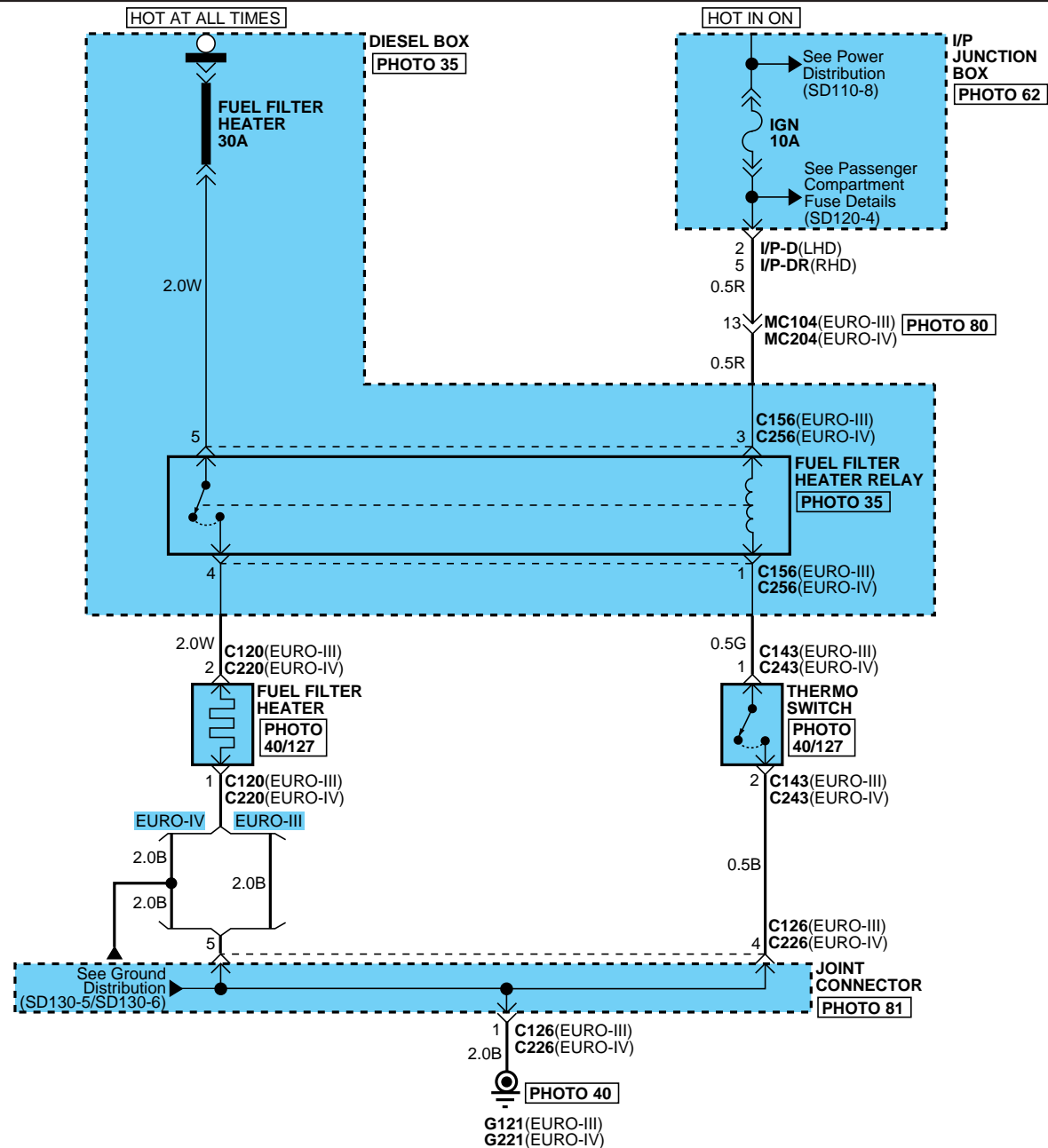

FUEL FILTER HEATING SYSTEM

FUEL FILTER HEATING SYSTEM (DIESEL) (2)

SD361-2

C120/C220

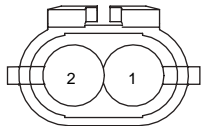

PKD_280WP_02F_B

C143/C243

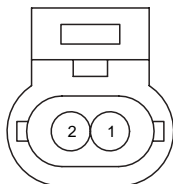

PKD_1.5WP_02F_B

C156/C256

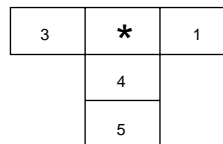

BLANK

CHARGING SYSTEM (1)

SD373-1

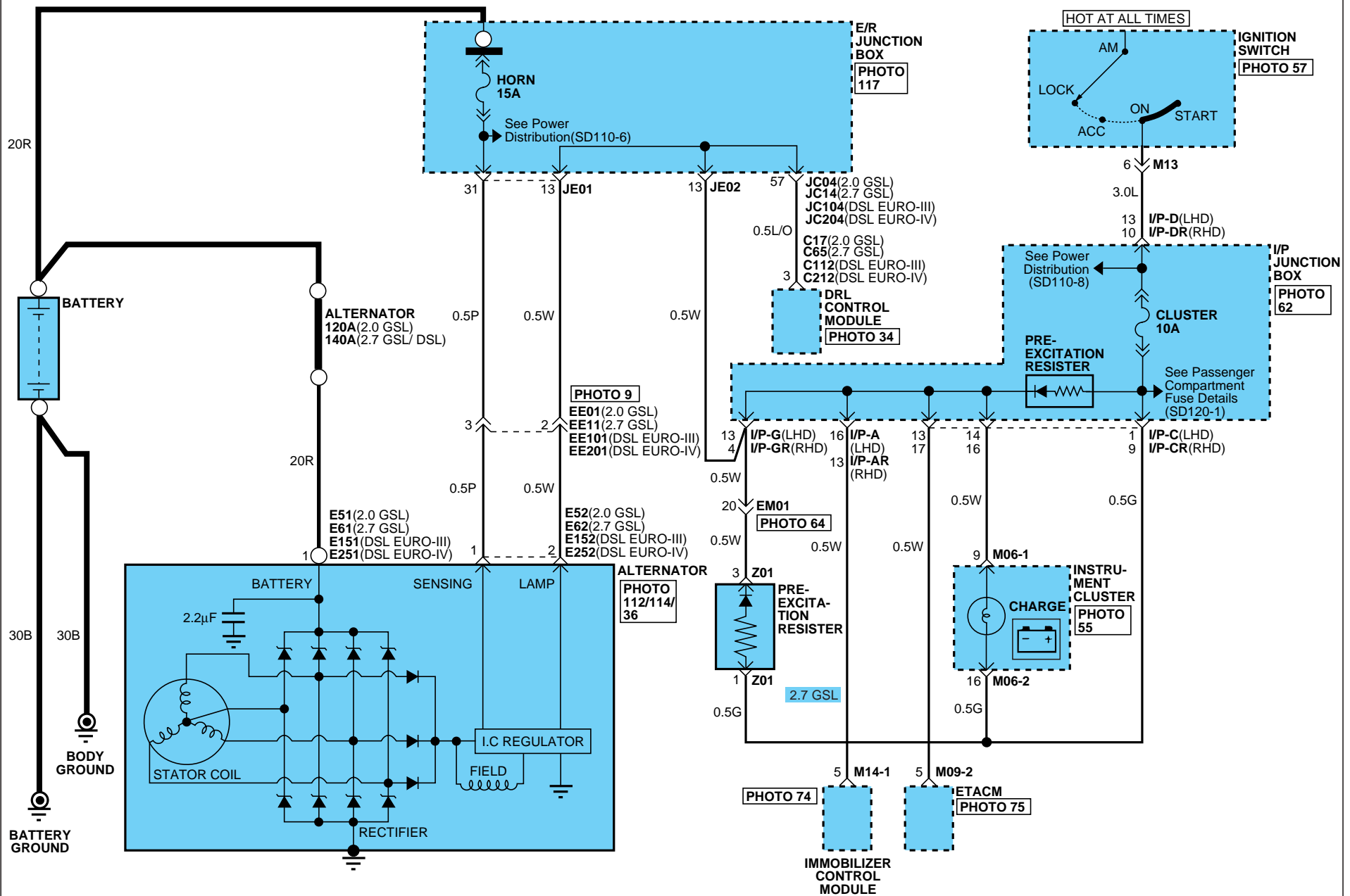

CHARGING SYSTEM

CHARGING SYSTEM (2)

SD373-2

C17/C65/C112/C212

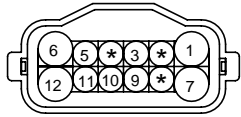

KET_1809WP_12F_Gr

E51/E61/E151/E251

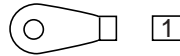

CR01F052

E52/E62/E152/E252

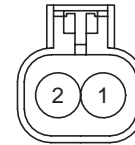

KET_58X_02F_B

M06-1

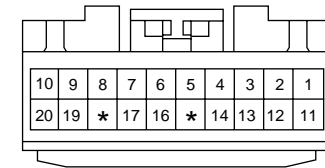

MLX_040III_20F_Gr

M06-2

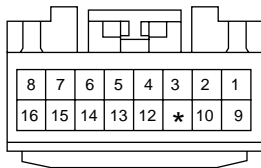

MLX_040_III_16F_Gr

M09-2

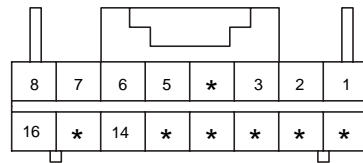

AMP_0407_16F_W_040

M14-1

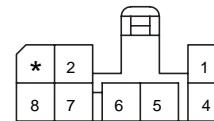

AMP_070_08F_W

Z01

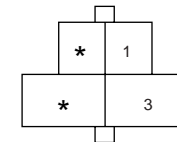

KET_250_04F_B_RLY

VEHICLE SPEED SENSOR (1)

SD436-1

GSL / DSL EURO-III

DSL EURO-IV

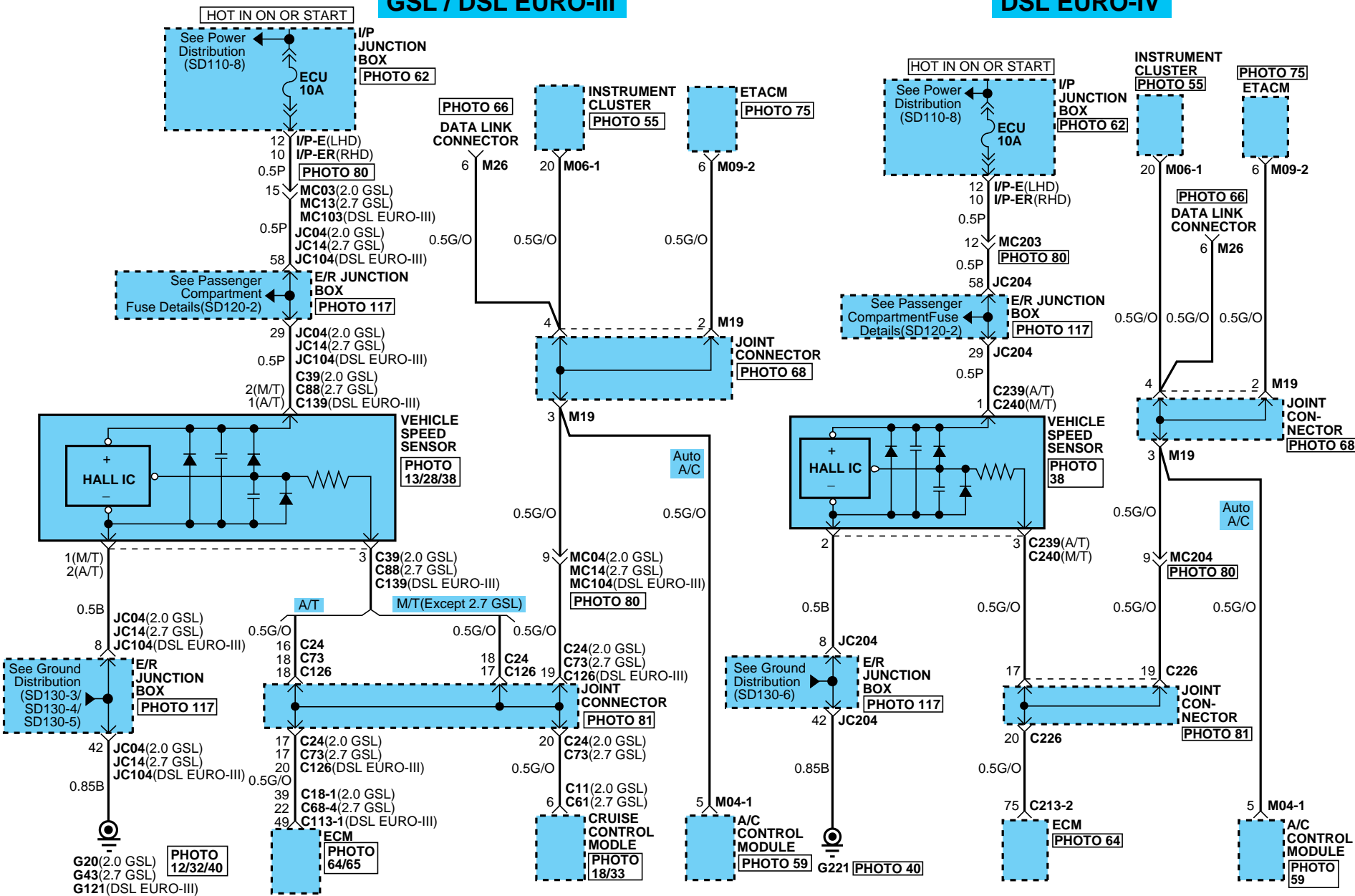

VEHICLE SPEED SENSOR

VEHICLE SPEED SENSOR (2)

SD436-2

C39/C88/C139/C239

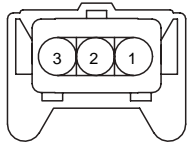

AMP_JPT_03F_B_S1

C240

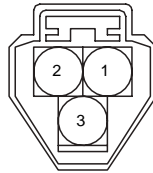

KUM_NMWP_03F_W

M04-1

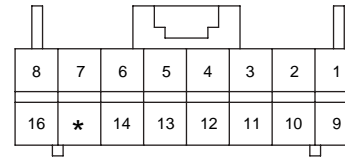

AMP_0407_16F_W_040

M06-1

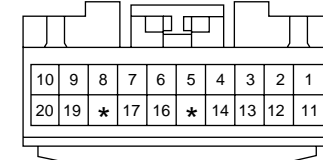

MLX_040III_20F_Gr

M09-2

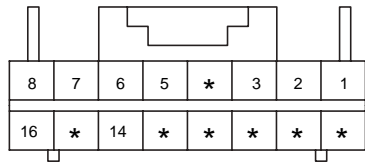

AMP_0407_16F_W_040

M26

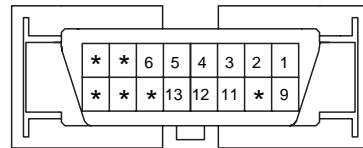

MLX_OBDII_16F_B_SIN

BLANK

BLANK

AUTOMATIC TRANSAXLE CONTROL SYSTEM (2.0 GASOLINE) (1)

SD450-1

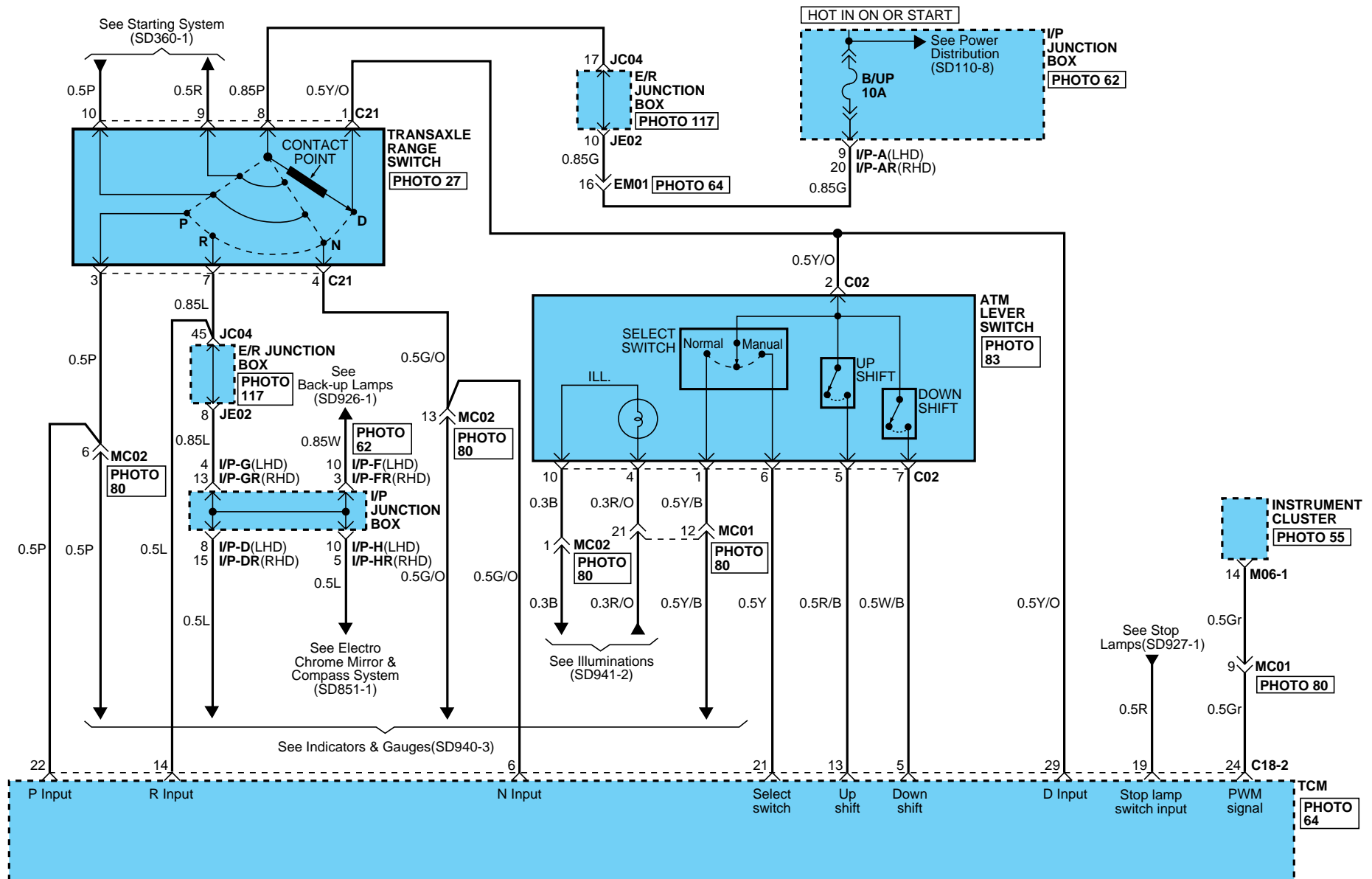

AUTOMATIC TRANSAXLE CONTROL SYSTEM

AUTOMATIC TRANSAXLE CONTROL SYSTEM (2.0 GASOLINE) (2)

SD450-2

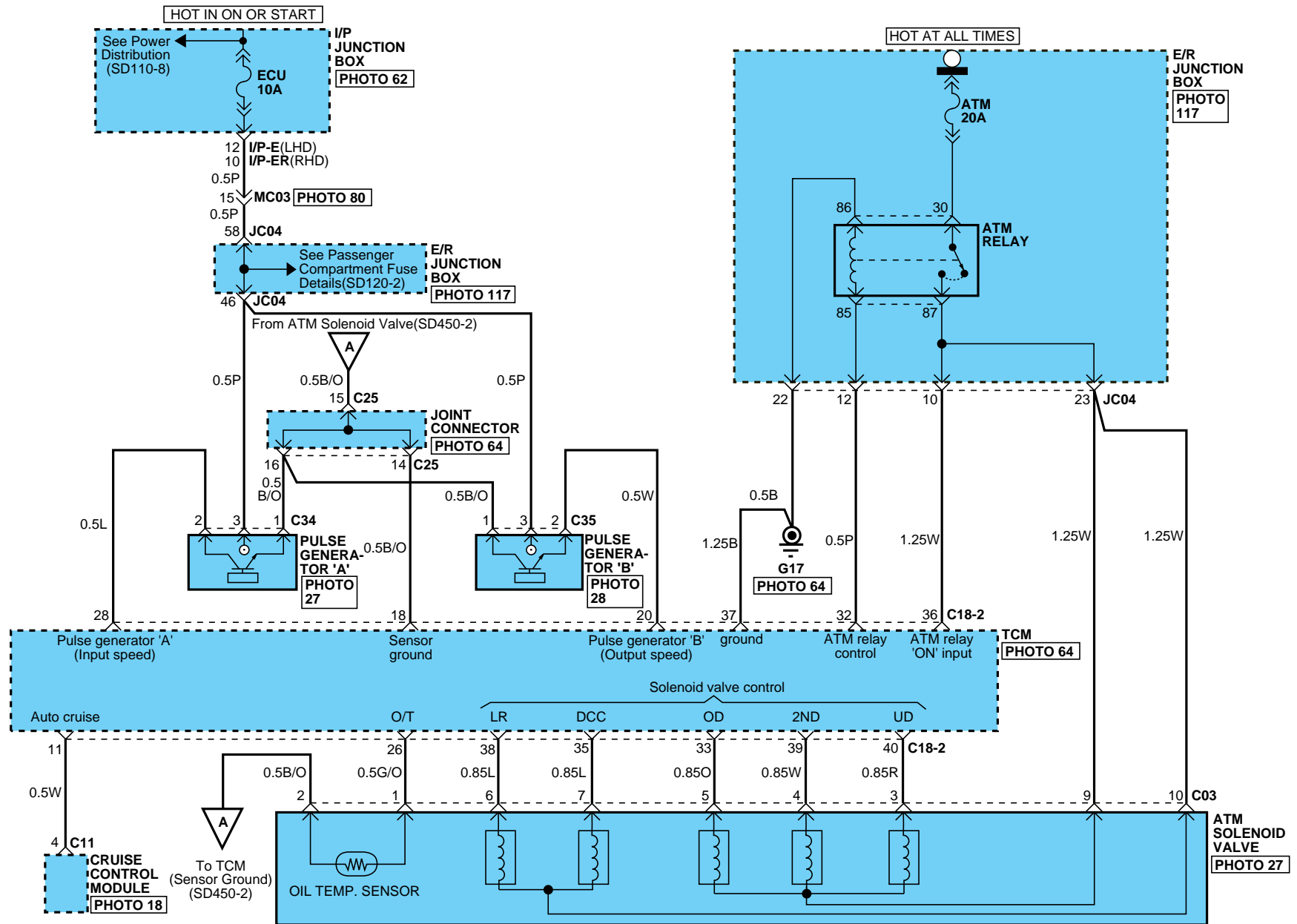

AUTOMATIC TRANSAXLE CONTROL SYSTEM

AUTOMATIC TRANSAXLE CONTROL SYSTEM (2.0 GASOLINE) (3)

SD450-3

C02

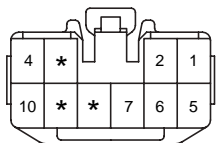

KET_090II_10F_W

C03

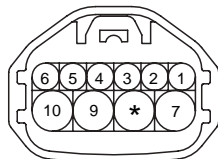

KET_SSD_10F_Gr_B

C18-2

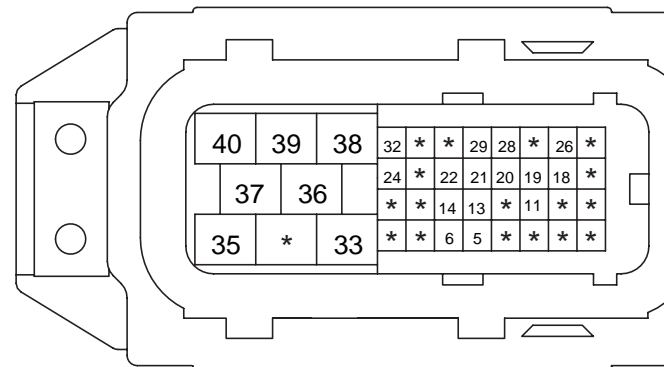

KET_ECU_40F_B

C21



KET_SSD_10F_B_A

C34



KET_SSD_03F_B_A

C35

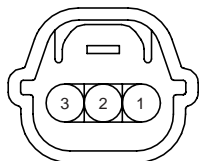

KET_SSD_03F_Gr_B

BLANK

BLANK

BLANK

AUTOMATIC TRANSAXLE CONTROL SYSTEM

AUTOMATIC TRANSAXLE CONTROL SYSTEM (2.0 GASOLINE) (4)

SD450-4

MEMO

AUTOMATIC TRANSAXLE CONTROL SYSTEM

AUTOMATIC TRANSAXLE CONTROL SYSTEM (2.7 GASOLINE/DIESEL EURO-III) (1)

SD450-5

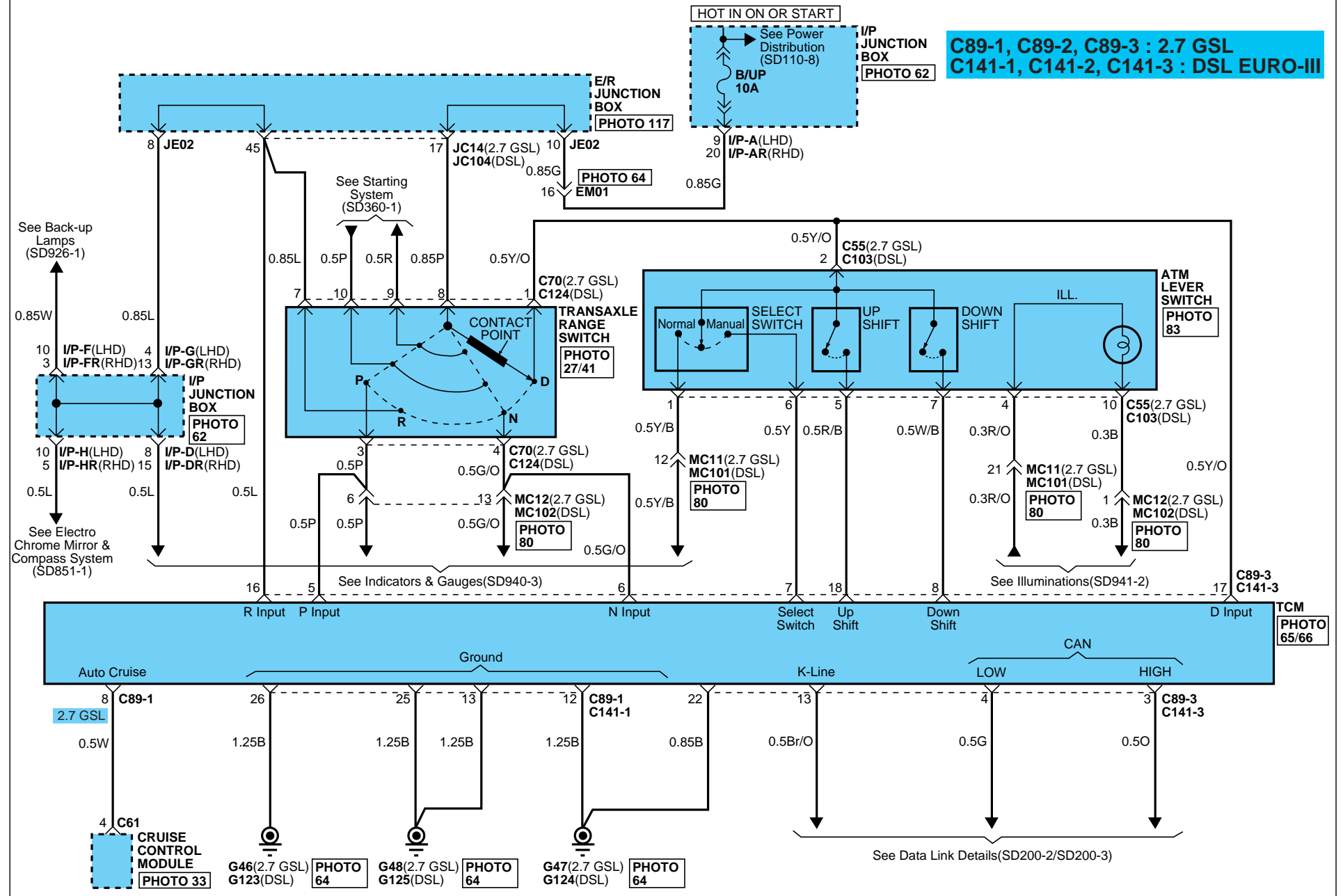

AUTOMATIC TRANSAXLE CONTROL SYSTEM

AUTOMATIC TRANSAXLE CONTROL SYSTEM (2.7 GASOLINE/DIESEL EURO-III) (2)

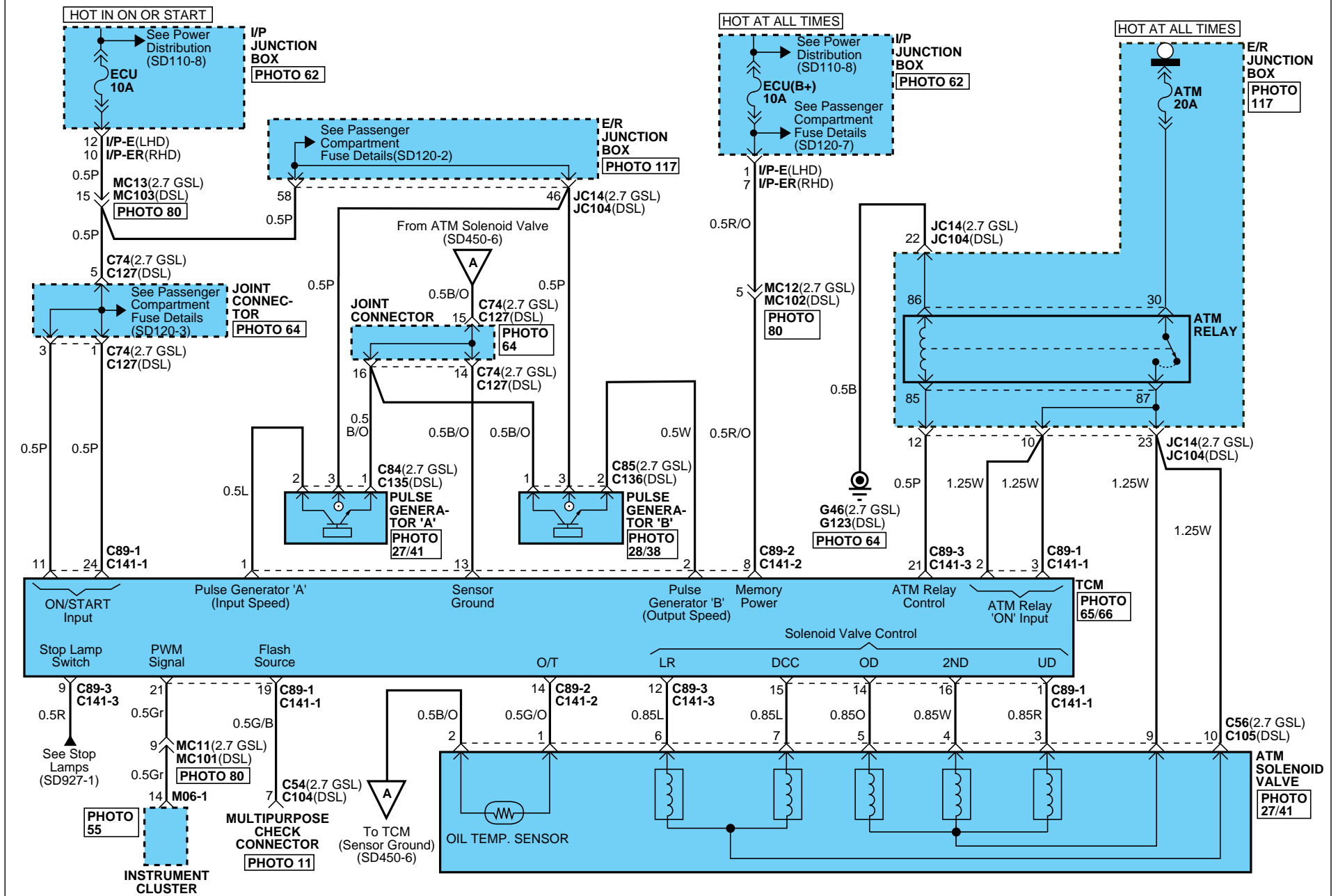

SD450-6



AUTOMATIC TRANSAXLE CONTROL SYSTEM

AUTOMATIC TRANSAXLE CONTROL SYSTEM (2.7 GASOLINE/DIESEL EURO-III) (3)

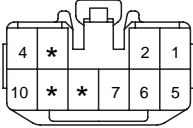
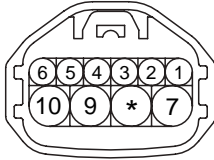
SD450-7

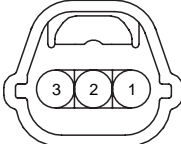
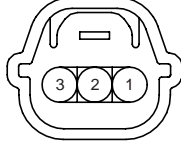
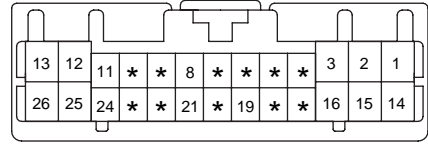
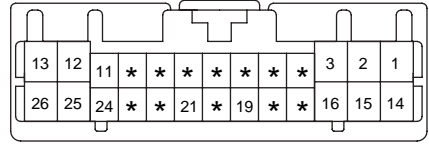
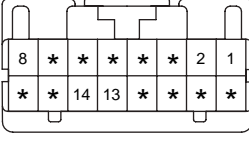
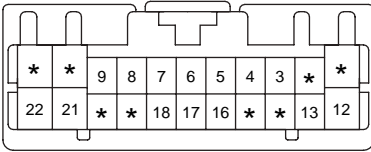
<p>C55/C103</p>  <p>KET_090II_10F_W</p>	<p>C56/C105</p>  <p>KET_SSD_10F_Gr_B</p>	<p>C70/C124</p>  <p>AMP_0407_26F_W-HD</p>	<p>C84/C135</p>  <p>KET_SSD_03F_B_A</p>
<p>C85/C136</p>  <p>KET_SSD_03F_Gr_B</p>	<p>C89-1</p>  <p>KET_0407_26F_W</p>	<p>C141-1</p>  <p>KET_0407_26F_W04F_B</p>	<p>C89-2/C141-2</p>  <p>KET_0407_16F_W</p>
<p>C89-3/C141-3</p>  <p>KET_0407_22F_W</p>	<p>BLANK</p>	<p>BLANK</p>	<p>BLANK</p>

AUTOMATIC TRANSAXLE CONTROL SYSTEM

AUTOMATIC TRANSAXLE CONTROL SYSTEM (2.7 GASOLINE/DIESEL EURO-III) (4)

SD450-8

MEMO

AUTOMATIC TRANSAXLE CONTROL SYSTEM (DIESEL EURO-IV) (1)

SD450-9

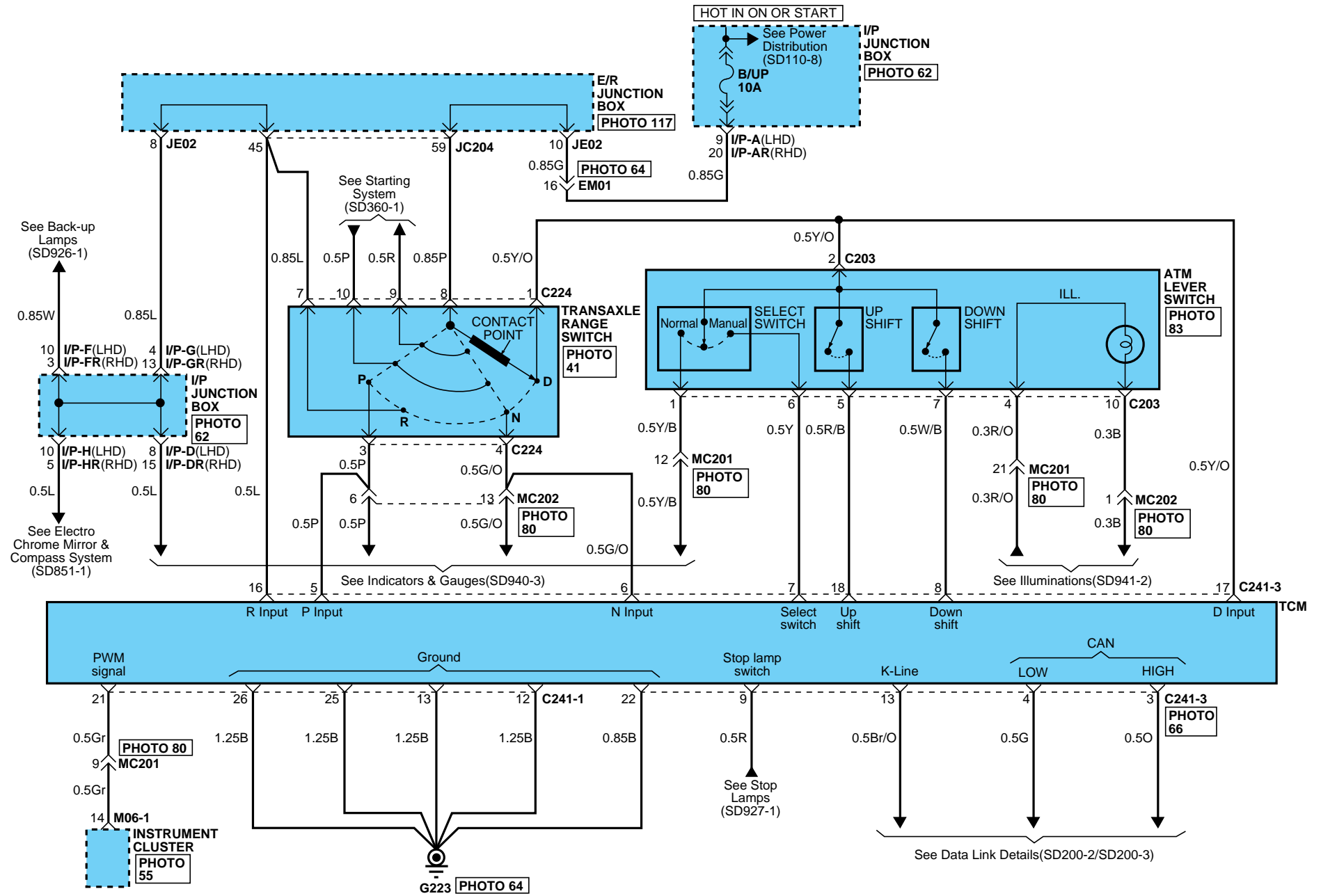

AUTOMATIC TRANSAXLE CONTROL SYSTEM

AUTOMATIC TRANSAXLE CONTROL SYSTEM (DIESEL EURO-IV) (2)

SD450-10

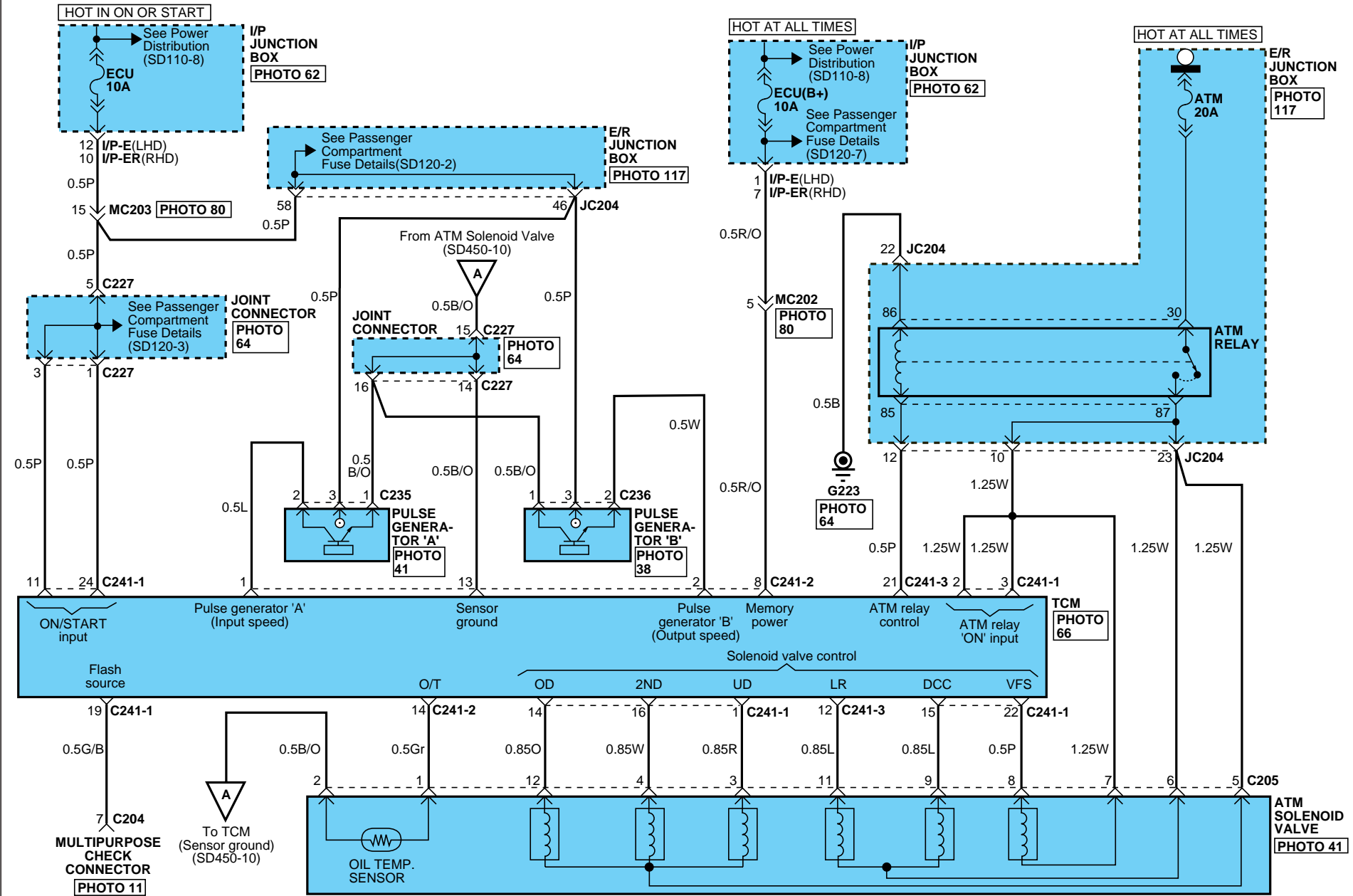

AUTOMATIC TRANSAXLE CONTROL SYSTEM

AUTOMATIC TRANSAXLE CONTROL SYSTEM (DIESEL EURO-IV) (3)

SD450-11

C203

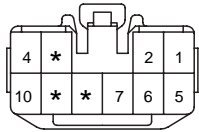

KET_090II_10F_W

C205



KET_SSD_12F_B

C224



AMP_0407_26F_W-HD

C235

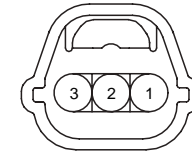

KET_SSD_03F_B_A

C236

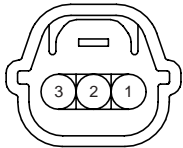

KET_SSD_03F_Gr_B

C241-1

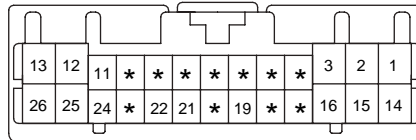

KET_0407_26F_W04F_B

C241-2

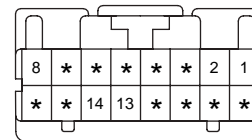

KET_0407_16F_W

C241-3

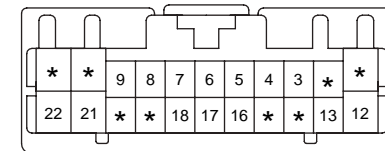

KET_0407_22F_W

AUTOMATIC TRANSAXLE CONTROL SYSTEM

AUTOMATIC TRANSAXLE CONTROL SYSTEM (DIESEL EURO-IV) (4)

SD450-12

MEMO

ELECTRONIC 4WD CONTROL SYSTEM (1)

SD527-1

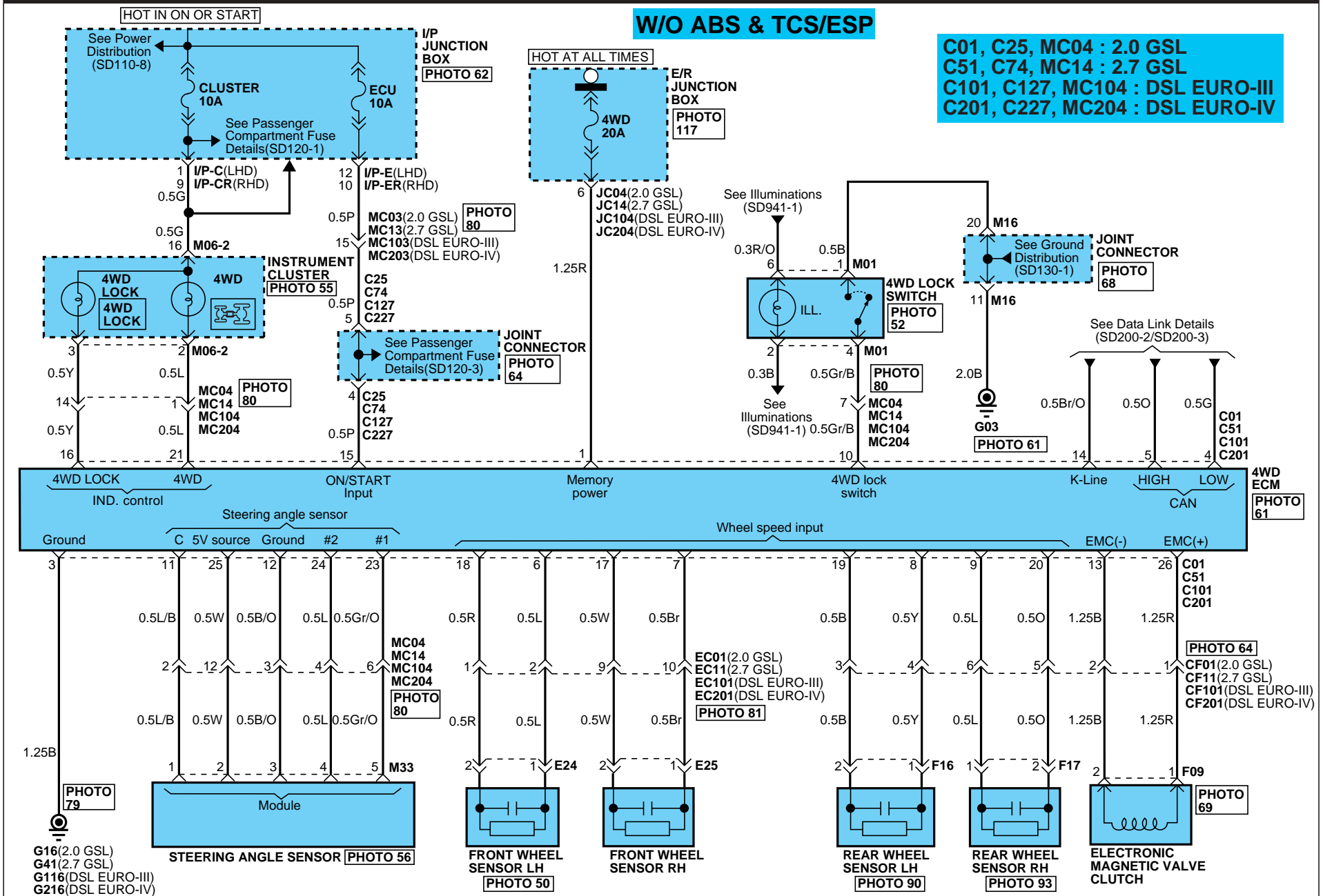

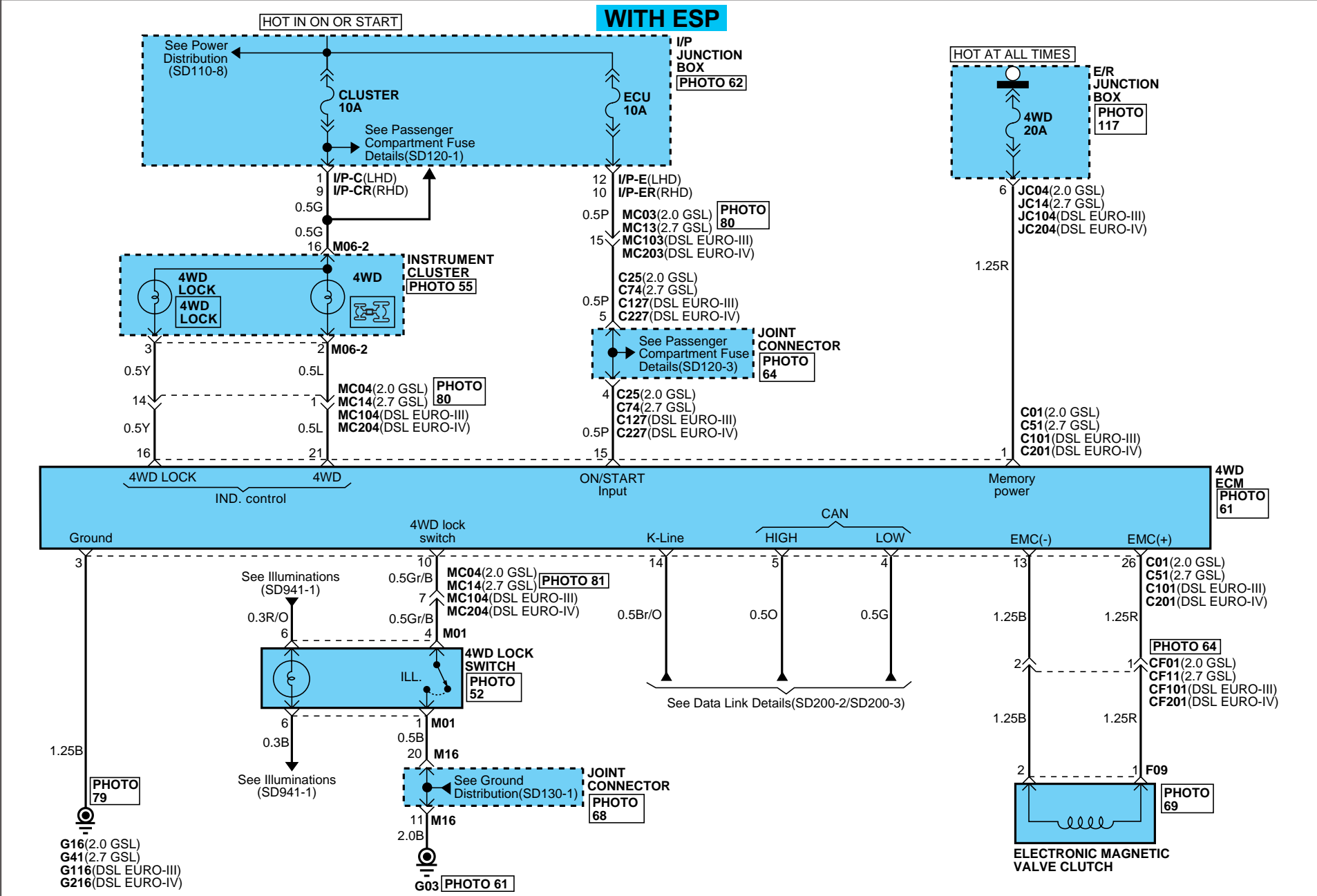

ELECTRONIC 4WD CONTROL SYSTEM

ELECTRONIC 4WD CONTROL SYSTEM (3)

SD527-3

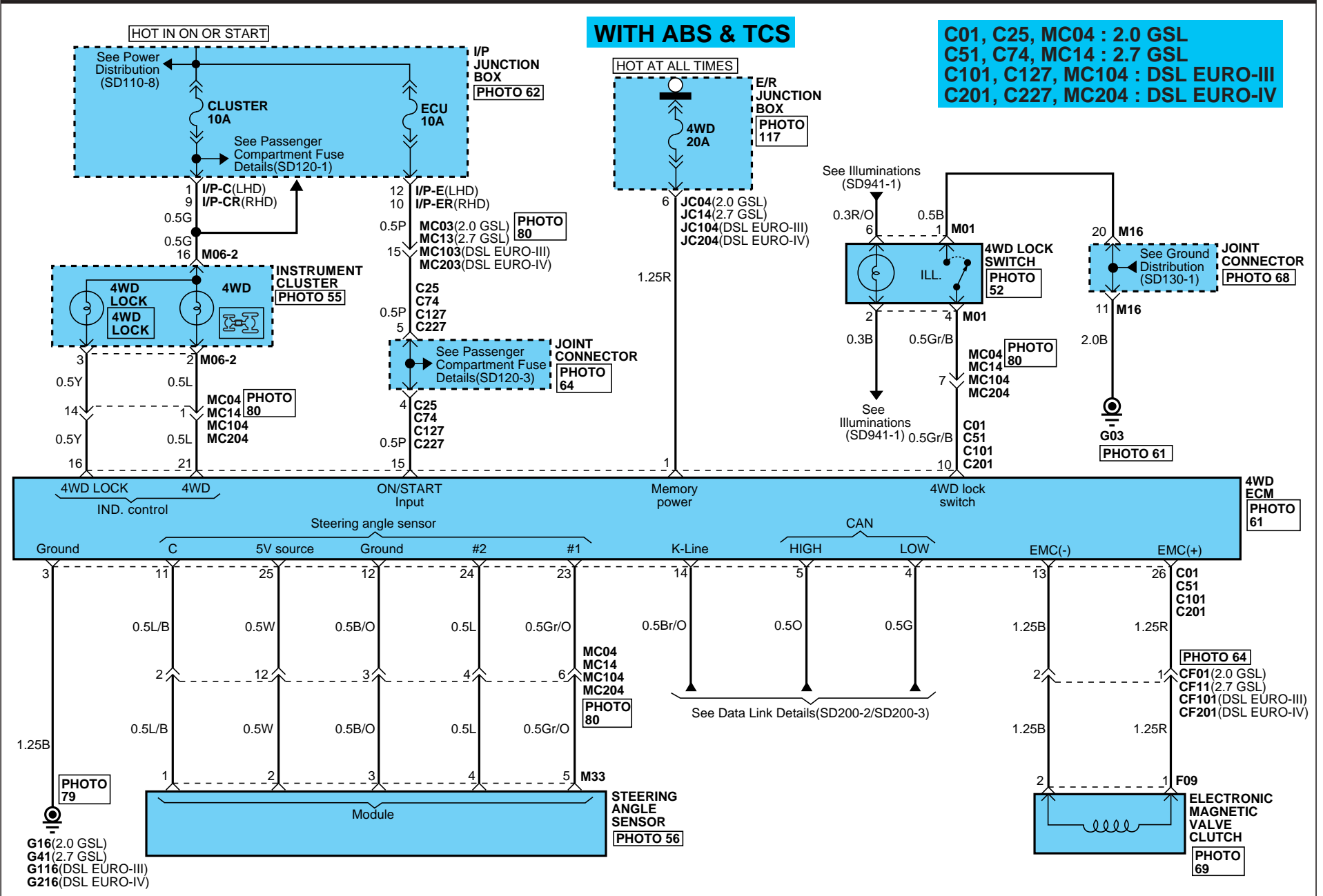

ELECTRONIC 4WD CONTROL SYSTEM

ELECTRONIC 4WD CONTROL SYSTEM (4)

SD527-4

C01/C51/C101/C201

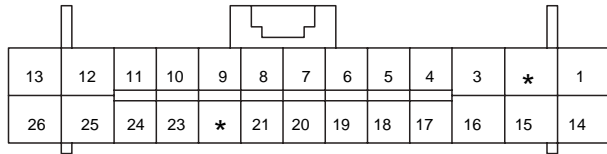

AMP_0407_26F_W_HD

E24

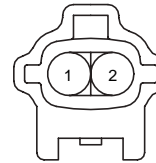

KET_090IWP_02M_B

E25

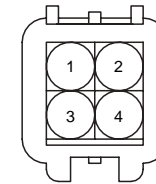

KUM_NMWP_04M_B

F09

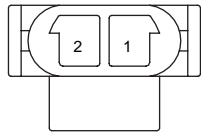

PKD_EMC_02F

F16

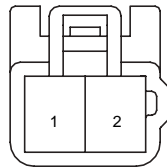

KET_090II_02M_W_L

F17

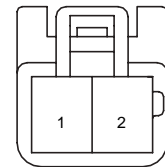

KET_090II_02M_W_L

M01

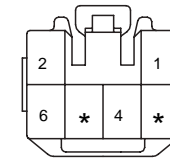

KET_090II_06F_L

M06-2

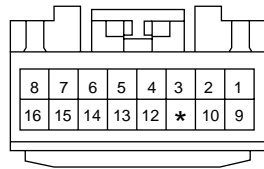

MLX_040III_16F_Gr

M33

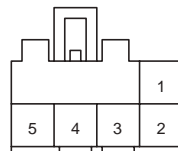

KUM_CDR_05F_B

BLANK

BLANK

AIR BAG SYSTEM (SRS) (1)

SD569-1

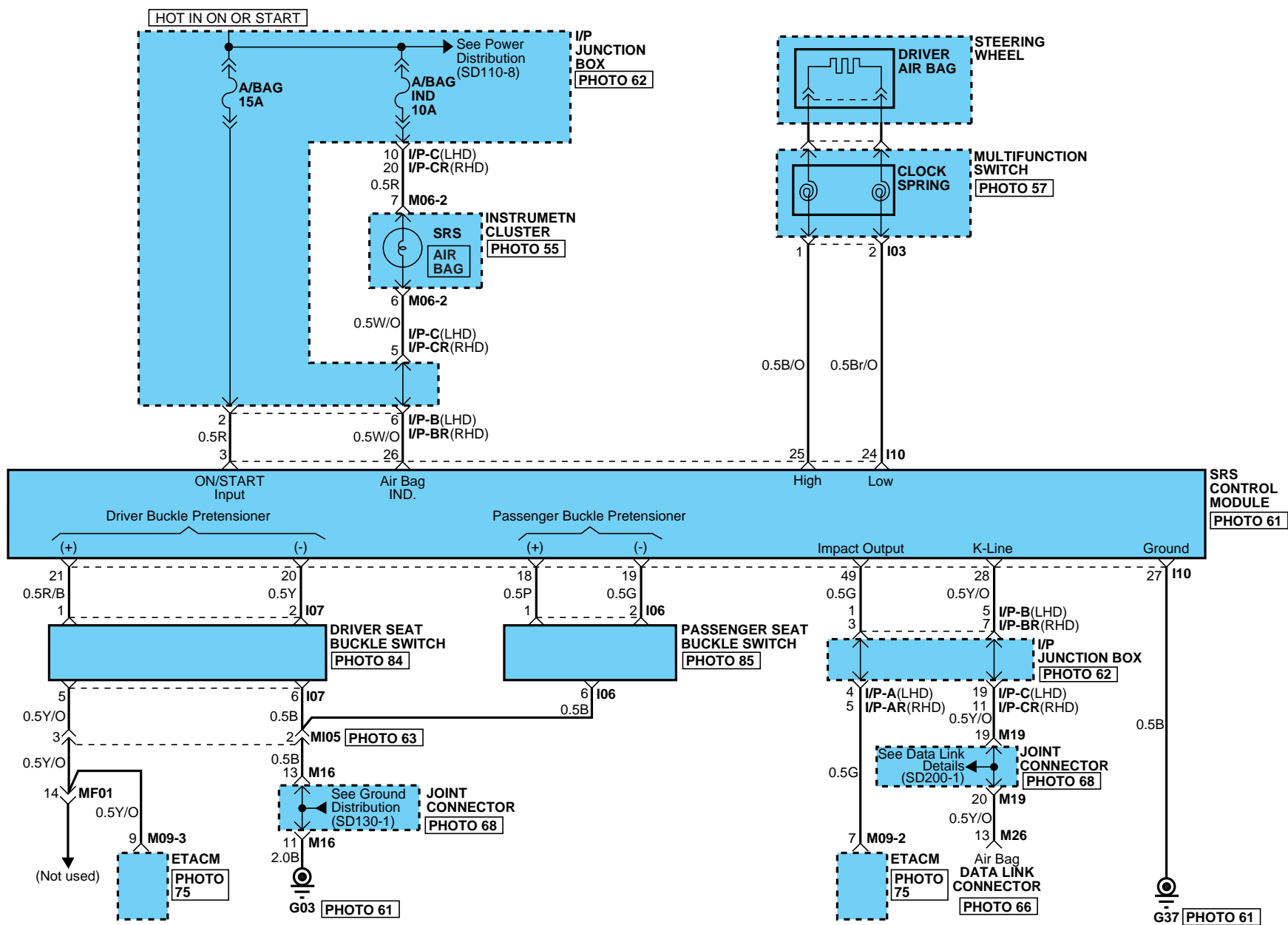

AIR BAG SYSTEM (SRS)

AIR BAG SYSTEM (SRS) (2)

SD569-2

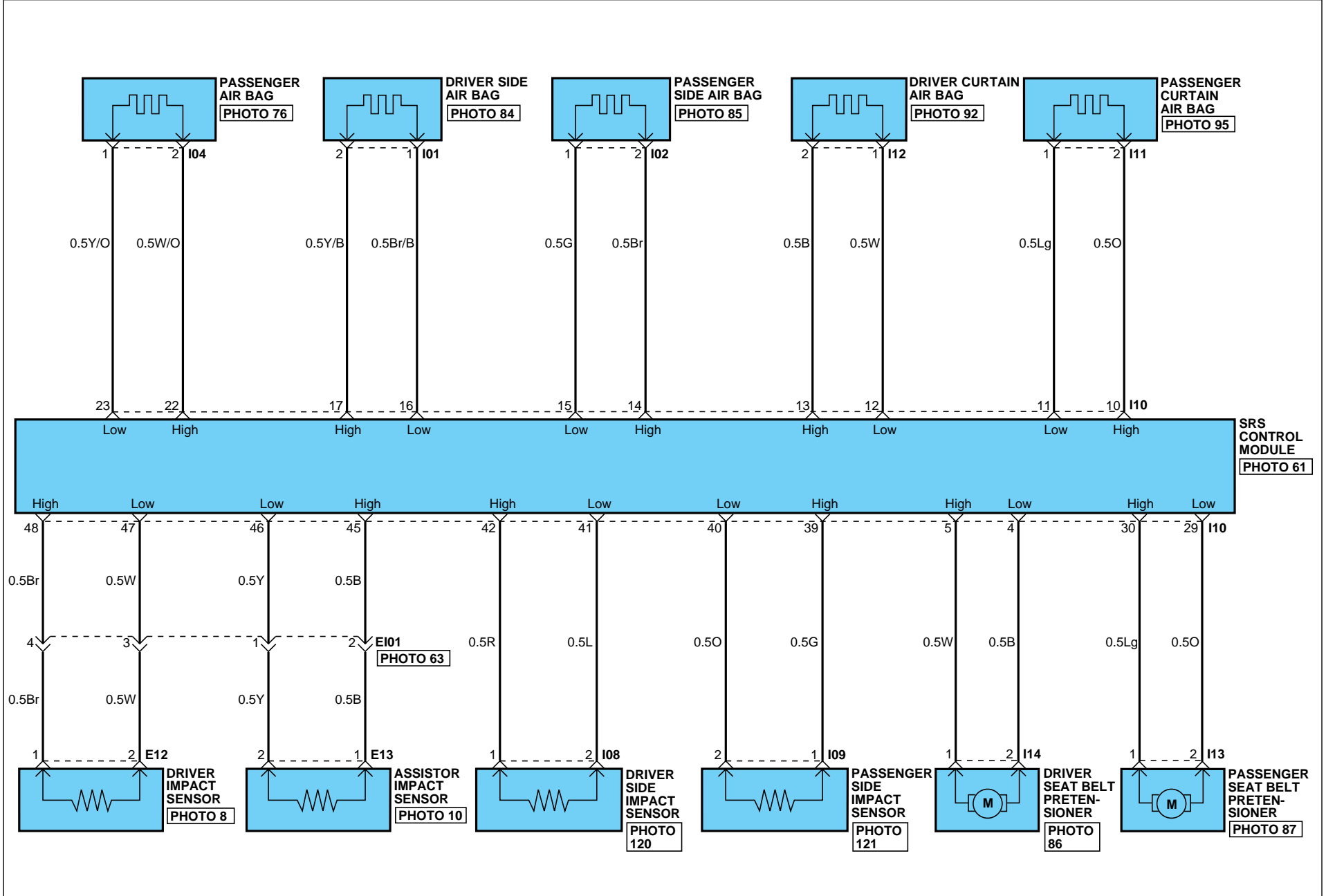

AIR BAG SYSTEM (SRS)

AIR BAG SYSTEM (SRS) (3)

SD569-3

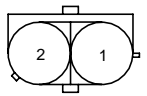
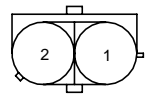
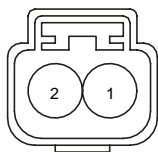
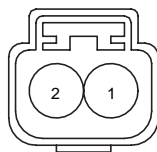
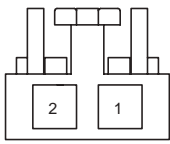
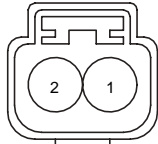
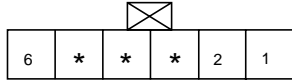
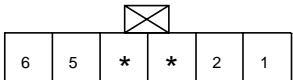
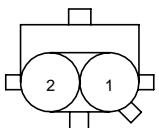
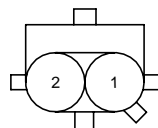
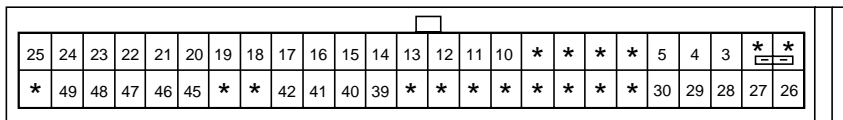
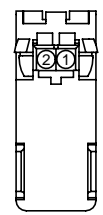
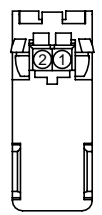
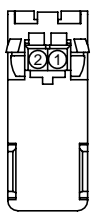
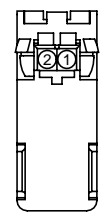
<p>E12</p>  <p>YAZ_ABAG_02F_0</p>	<p>E13</p>  <p>YAZ_ABAG_02F_0</p>	<p>I01</p>  <p>YAZ_040WP_02F_Y</p>	<p>I02</p>  <p>YAZ_040WP_02F_Y</p>
<p>I03</p>  <p>YAZ_DAB_02F_Y</p>	<p>I04</p>  <p>YAZ_ABG_2F</p>	<p>I06</p>  <p>AMP_MQS_6F</p>	<p>I07</p>  <p>AMP_MQS_6F</p>
<p>I08</p>  <p>HMC_DUMMY_02F_N</p>	<p>I09</p>  <p>HMC_DUMMY_02F_N</p>	<p>I10</p>  <p>AMP_ABG_50F</p>	
<p>I11</p>  <p>FCL_SQUIB_2F</p>	<p>I12</p>  <p>FCL_SQUIB_2F</p>	<p>I13</p>  <p>FCL_SQUIB_2F</p>	<p>I14</p>  <p>FCL_SQUIB_2F</p>

AIR BAG SYSTEM (SRS)

AIR BAG SYSTEM (SRS) (4)

SD569-4

MEMO

ANTI-LOCK BRAKE SYSTEM/ TRACTION CONTROL SYSTEM (1)

SD587-1

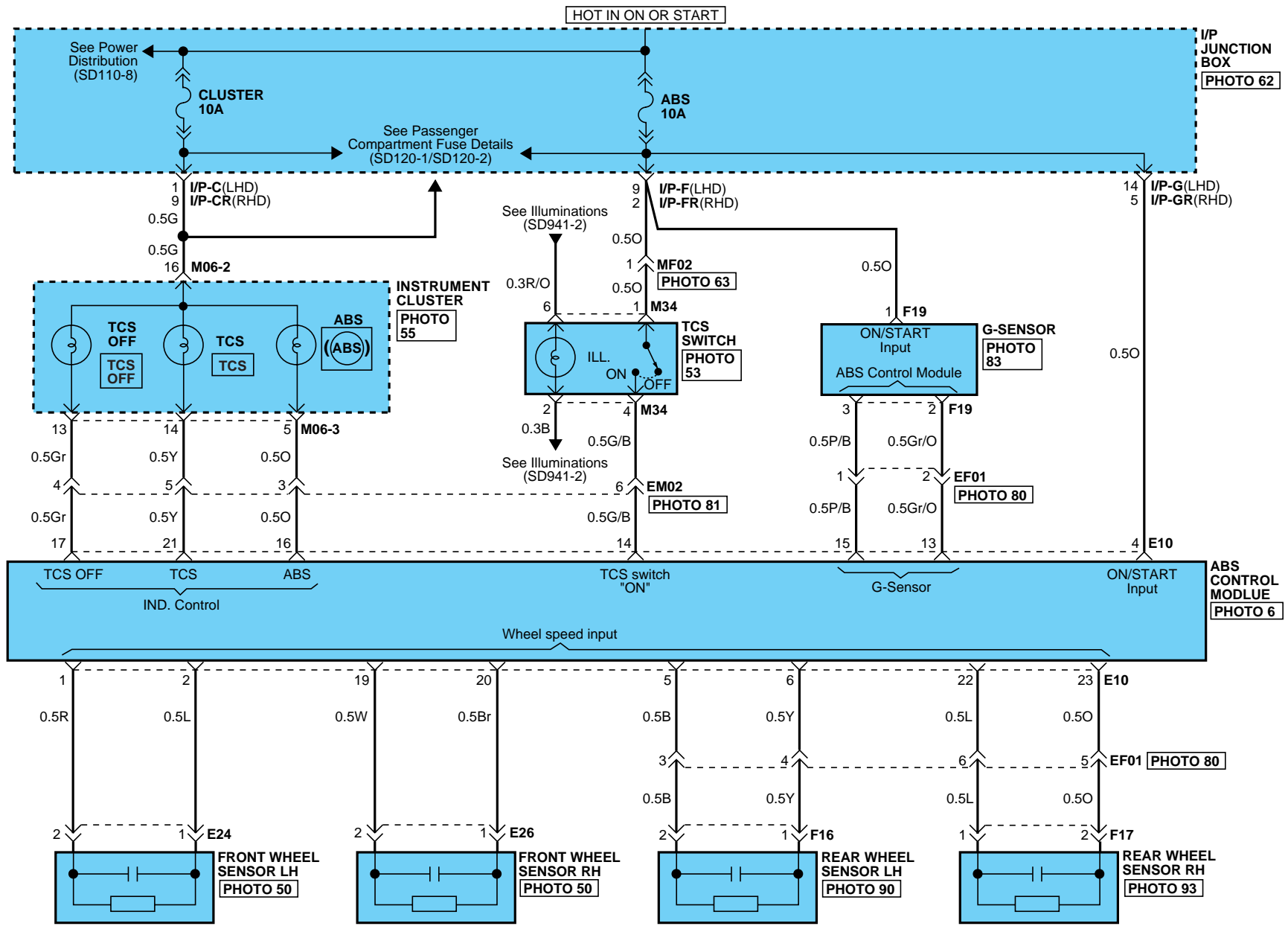

ANTI-LOCK BRAKE SYSTEM/ TRACTION CONTROL SYSTEM

ANTI-LOCK BRAKE SYSTEM/ TRACTION CONTROL SYSTEM (2)

SD587-2

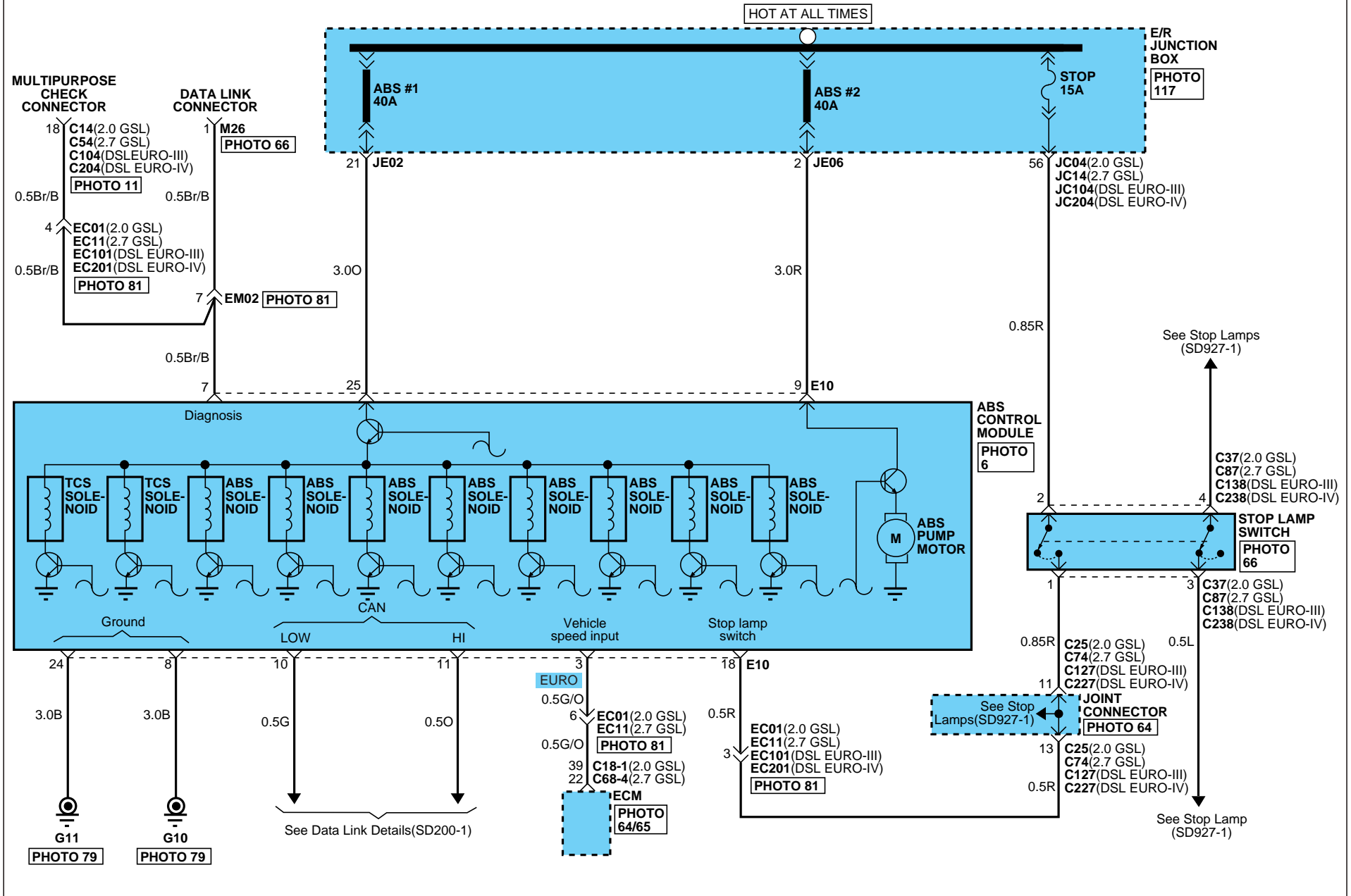

ANTI-LOCK BRAKE SYSTEM/ TRACTION CONTROL SYSTEM

ANTI-LOCK BRAKE SYSTEM/ TRACTION CONTROL SYSTEM (3)

SD587-3

C37/C87/C138/C238

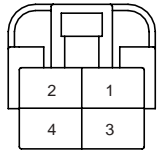

KET_250DL_04F_W

E10

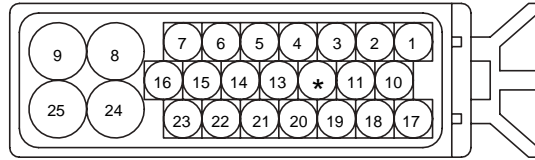

AMP_ABSWP_25F_B_GER

E24

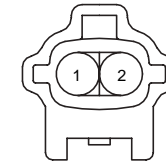

KET_090IWP_02M_B

E26

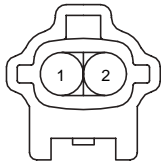

KET_090IWP_02M_B

F16

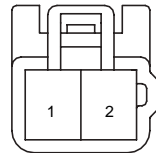

KET_090II_02M_W_L

F17

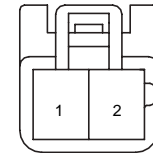

KET_090II_02M_W_L

F19

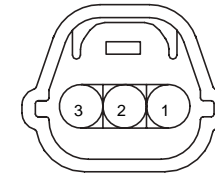

KET_SSD_03F_B_A

M06-2

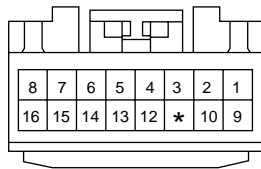

MLX_040III_16F_Gr

M06-3

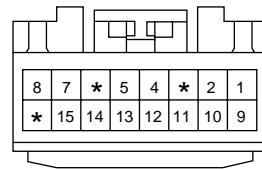

MLX_040III_16F_Gr

M34

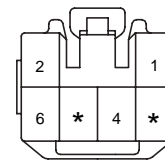

KET_090II_06F_W

BLANK

ANTI-LOCK BRAKE SYSTEM/ TRACTION CONTROL SYSTEM

ANTI-LOCK BRAKE SYSTEM/ TRACTION CONTROL SYSTEM (4)

SD587-4

MEMO

ELECTRONIC STABILITY PROGRAM (ESP) SYSTEM (1)

SD589-1

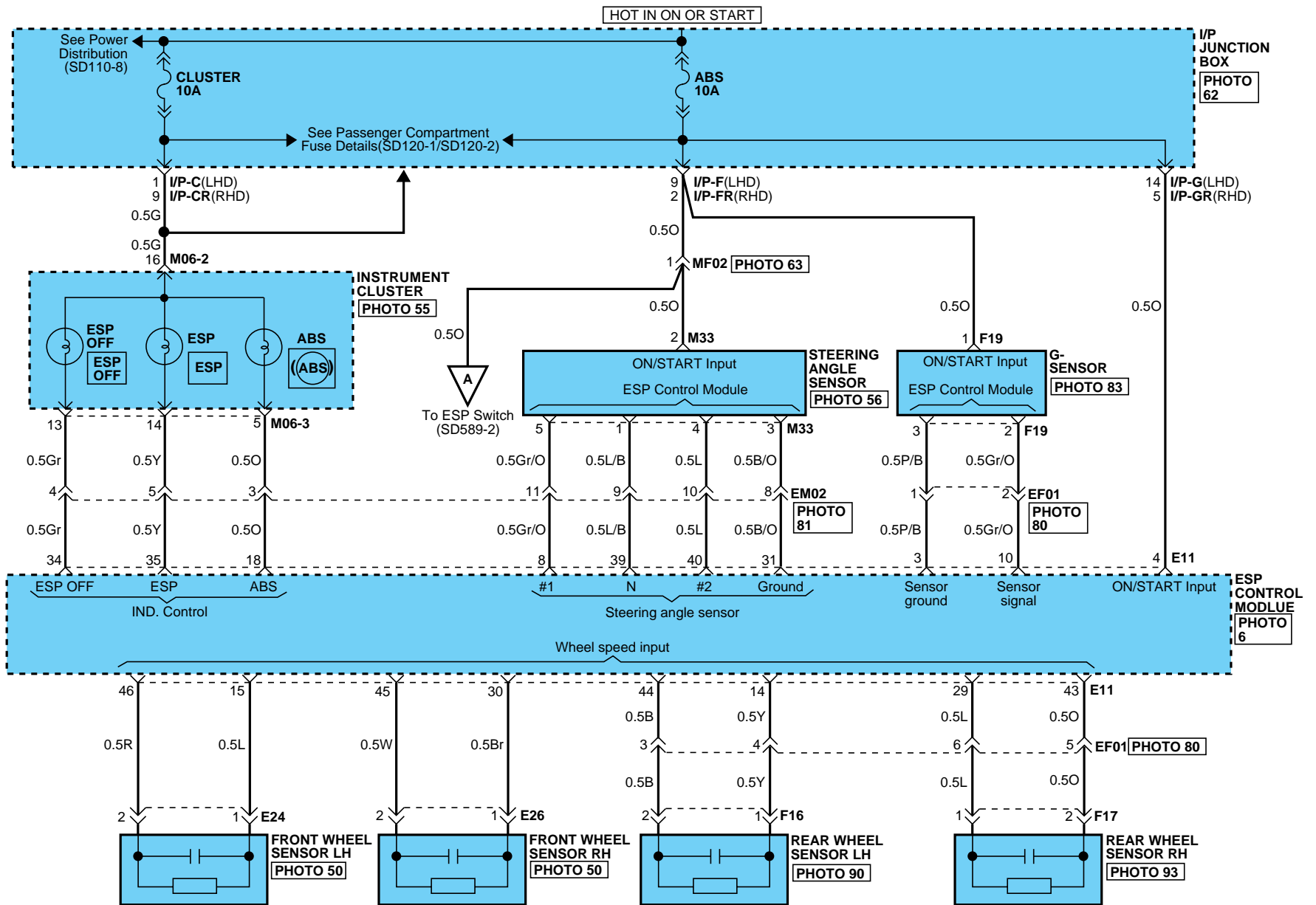

ELECTRONIC STABILITY PROGRAM (ESP) SYSTEM

ELECTRONIC STABILITY PROGRAM (ESP) SYSTEM (2)

SD589-2

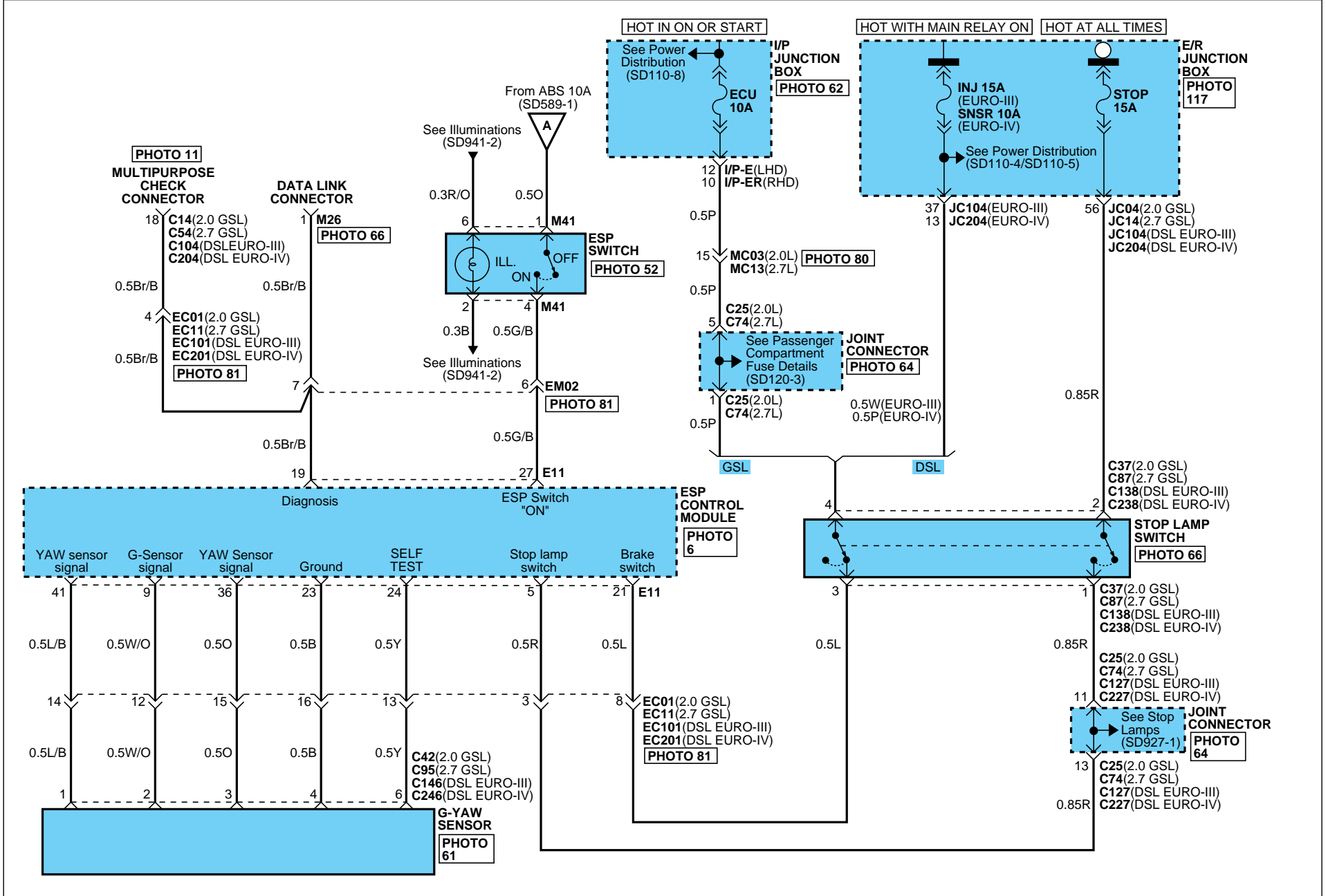

ELECTRONIC STABILITY PROGRAM (ESP) SYSTEM

ELECTRONIC STABILITY PROGRAM (ESP) SYSTEM (3)

SD589-3

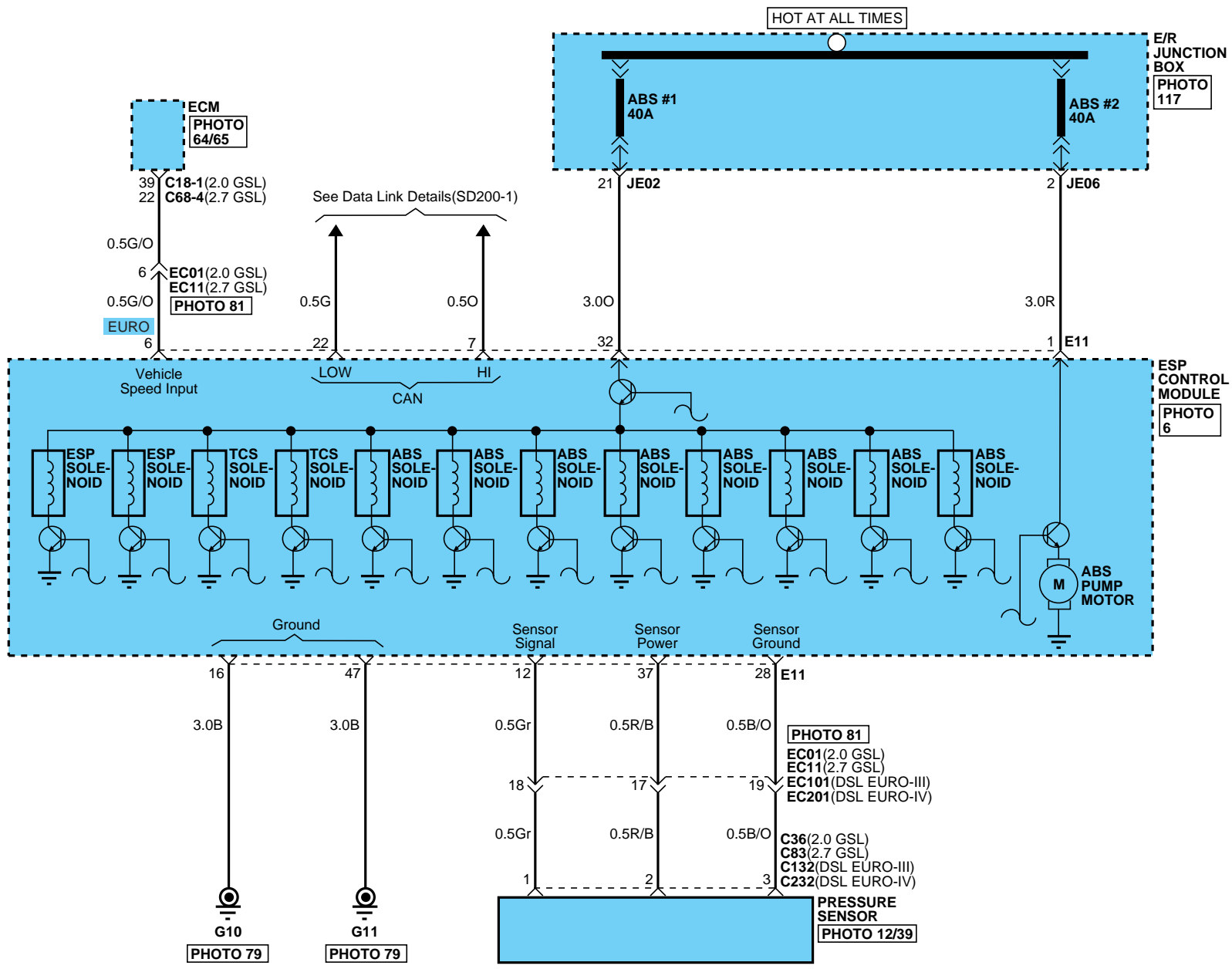

ELECTRONIC STABILITY PROGRAM (ESP) SYSTEM

ELECTRONIC STABILITY PROGRAM (ESP) SYSTEM (4)

SD589-4

C36/C83/C132/C232

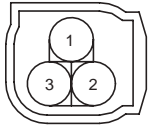

AMP_MQSWP_03F_B_1

C37/C87/C138/C238

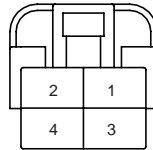

KET_250DL_04F_W

C42/C95

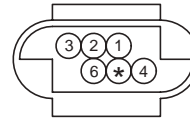

AMP_MQSWP_06F_B

C146/C246

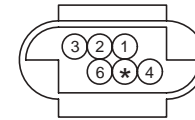

AMP_MQSWP_06F_GR_1

E11

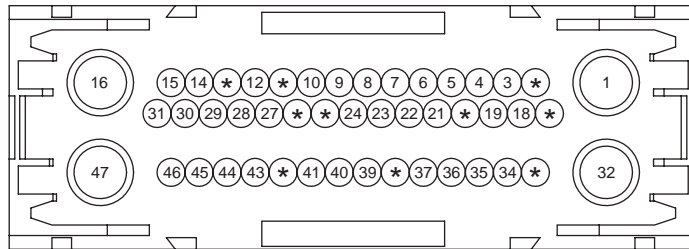

AMP_ABS_47F_B

E24

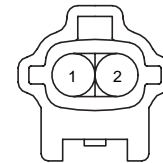

KET_090IWP_02M_B

E26

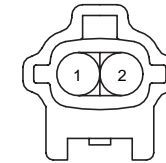

KET_090IWP_02M_B

F16

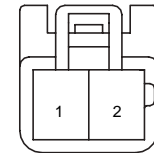

KET_090II_02M_W_L

F17

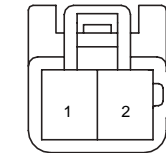

KET_090II_02M_W_L

F19

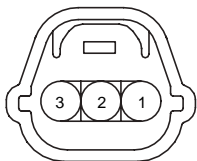

KET_SSD_03F_B_A

M33

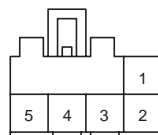

KUM_CDR_05F_B

M41

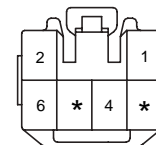

KET_090II_06F_W

BLANK

POWER DOOR LOCKS (1)

SD813-1

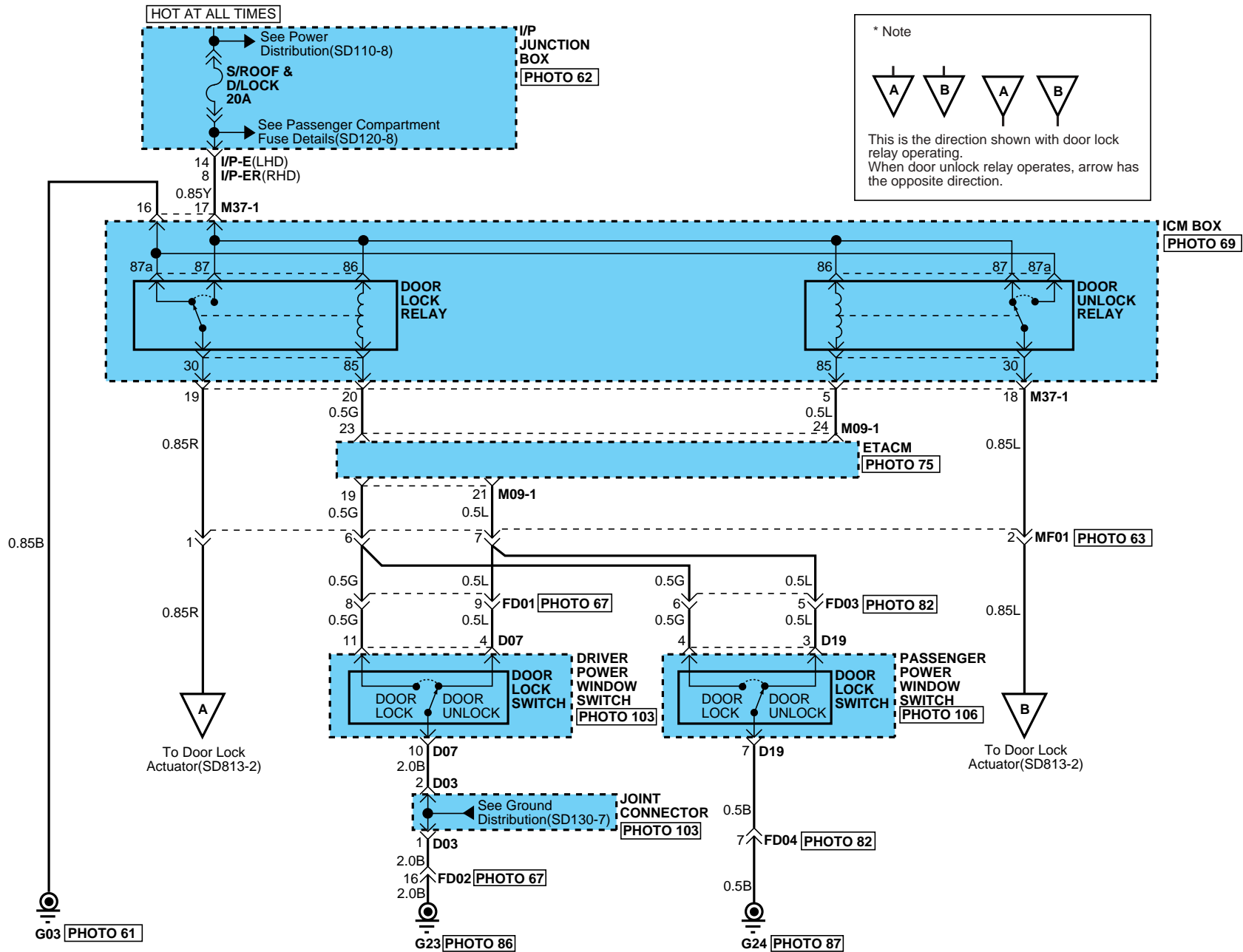







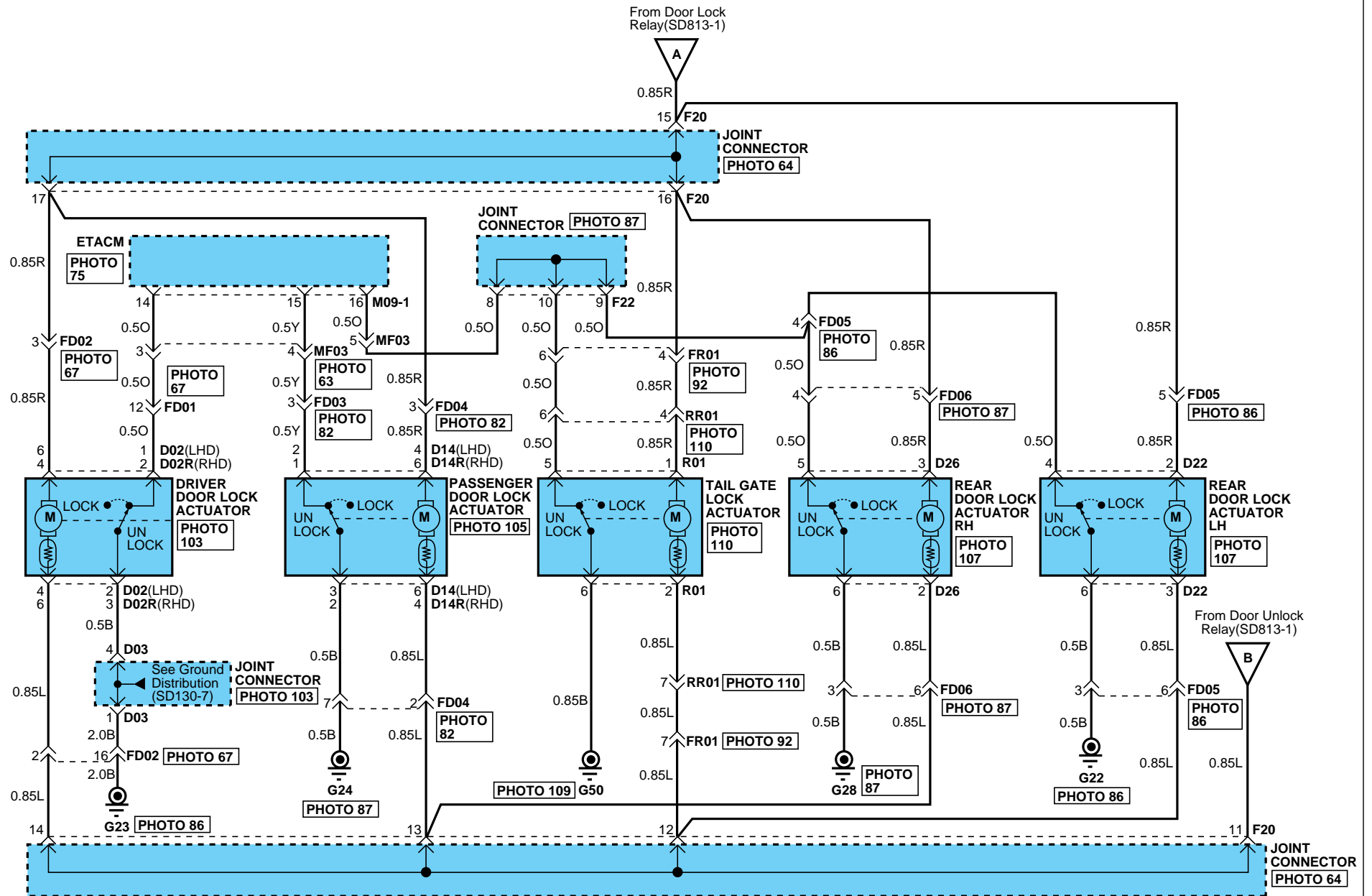

POWER DOOR LOCKS

POWER DOOR LOCKS (2)

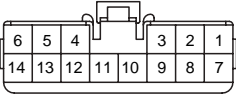
SD813-2

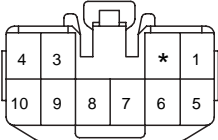

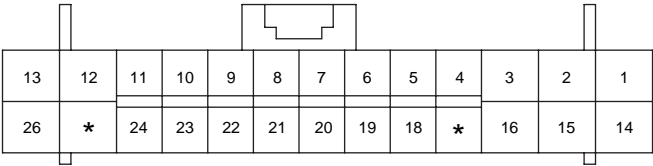
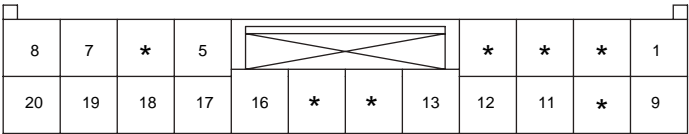
POWER DOOR LOCKS

POWER DOOR LOCKS (3)			SD813-3
<p>D02</p>  <p>KET_SSD_06F_B</p>	<p>D02R</p>  <p>KET_SSD_06F_B</p>	<p>D07</p>  <p>KET_090II_14F_W</p>	<p>D14</p>  <p>KET_SSD_06F_B</p>
<p>D14R</p>  <p>KET_SSD_06F_B</p>	<p>D19</p>  <p>KET_090II_10F_W</p>	<p>D22</p>  <p>KET_SSD_06F_B</p>	<p>D26</p>  <p>KET_SSD_06F_B</p>
<p>M09-1</p>  <p>AMP_0407_26F_W_HD</p>		<p>M37-1</p>  <p>AMP_0925_20F_W</p>	
<p>R01</p>  <p>KET_SSD_06F_B</p>	<p>BLANK</p>	<p>BLANK</p>	<p>BLANK</p>

POWER DOOR LOCKS

POWER DOOR LOCKS (4)

SD813-4

MEMO

KEYLESS ENTRY & BURGLAR ALARM SYSTEM (1)

SD814-1

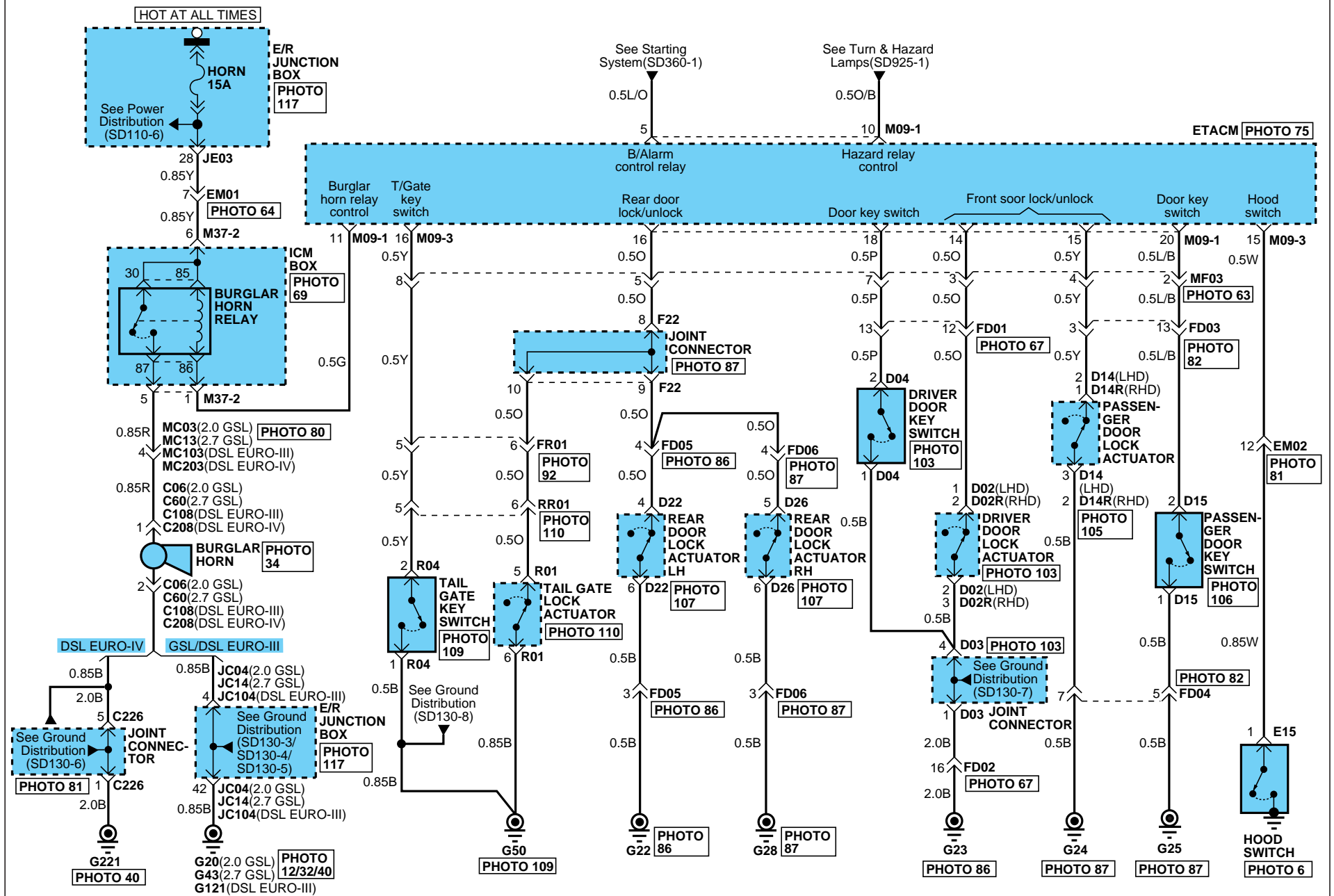

KEYLESS ENTRY & BURGLAR ALARM SYSTEM

KEYLESS ENTRY & BURGLAR ALARM SYSTEM (2)

SD814-2

C06/C60/C108/C208

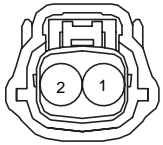

MLX_HORN_02F_B_FILT

D02/D14R



KET_SSD_06F_B

D04

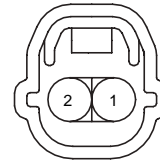

KET_SSD_02F_B

D02R/D14



KET_SSD_06F_B

D15

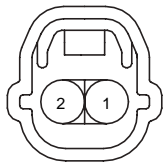

KET_SSD_02F_B

D22



KET_SSD_06F_B

D26



KET_SSD_06F_B

E15



KUM_NMWP_01F_B

M09-1

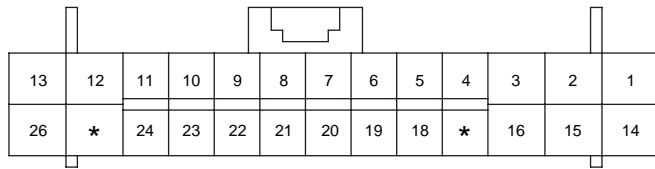

AMP_0407_26F_W_HD

M09-3

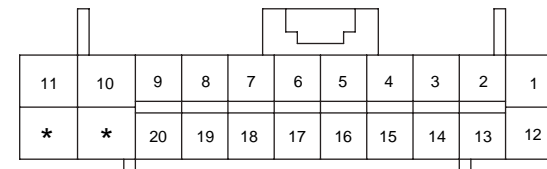

AMP_0407_22F_W_HD

M37-2

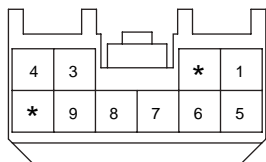

AMP_090III_10F_W

R01



KET_SSD_06F_B

R04

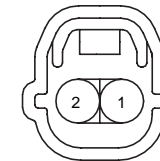

KET_SSD_02F_B

BLANK

SUNROOF (1)

SD816-1

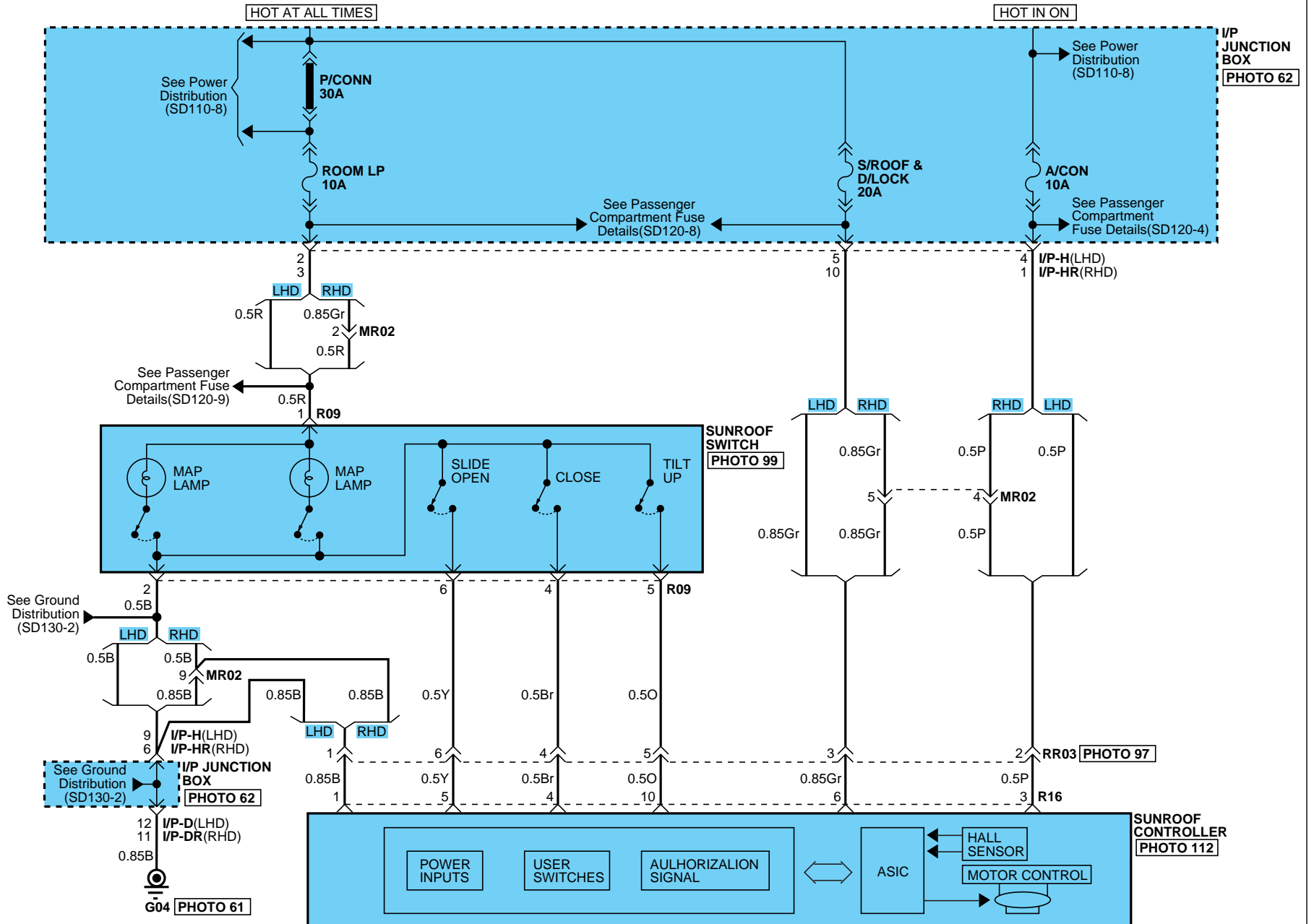

SUNROOF

SUNROOF (2)

SD816-2

R09

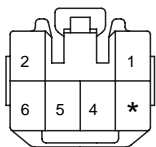

KET_090II_06F_W

R16

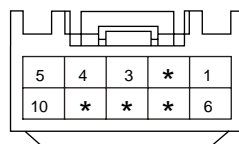

YAZ_1.5SYS_10F

BLANK

BLANK

POWER WINDOWS (1)

SD824-1

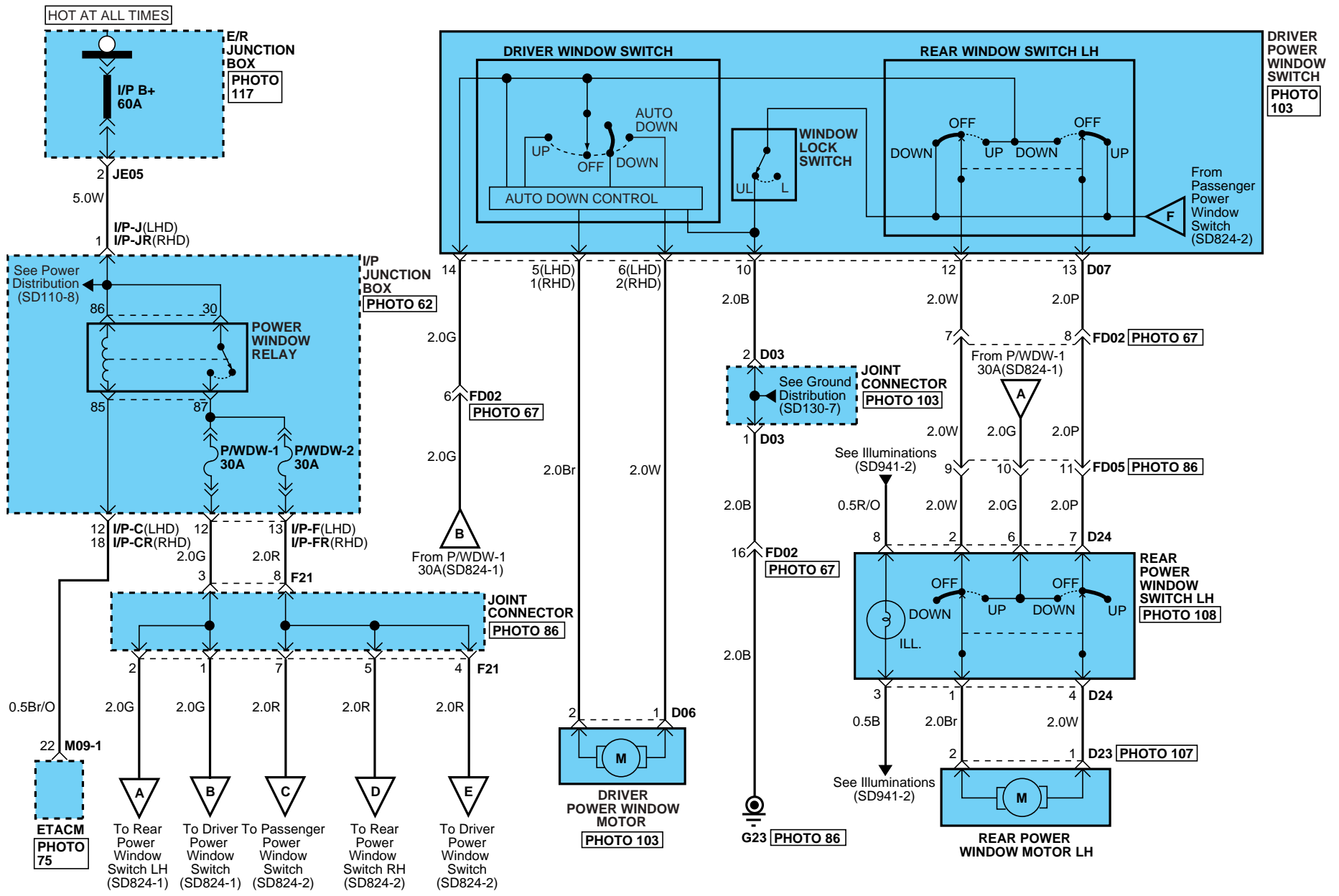

POWER WINDOWS

POWER WINDOWS (2)

SD824-2

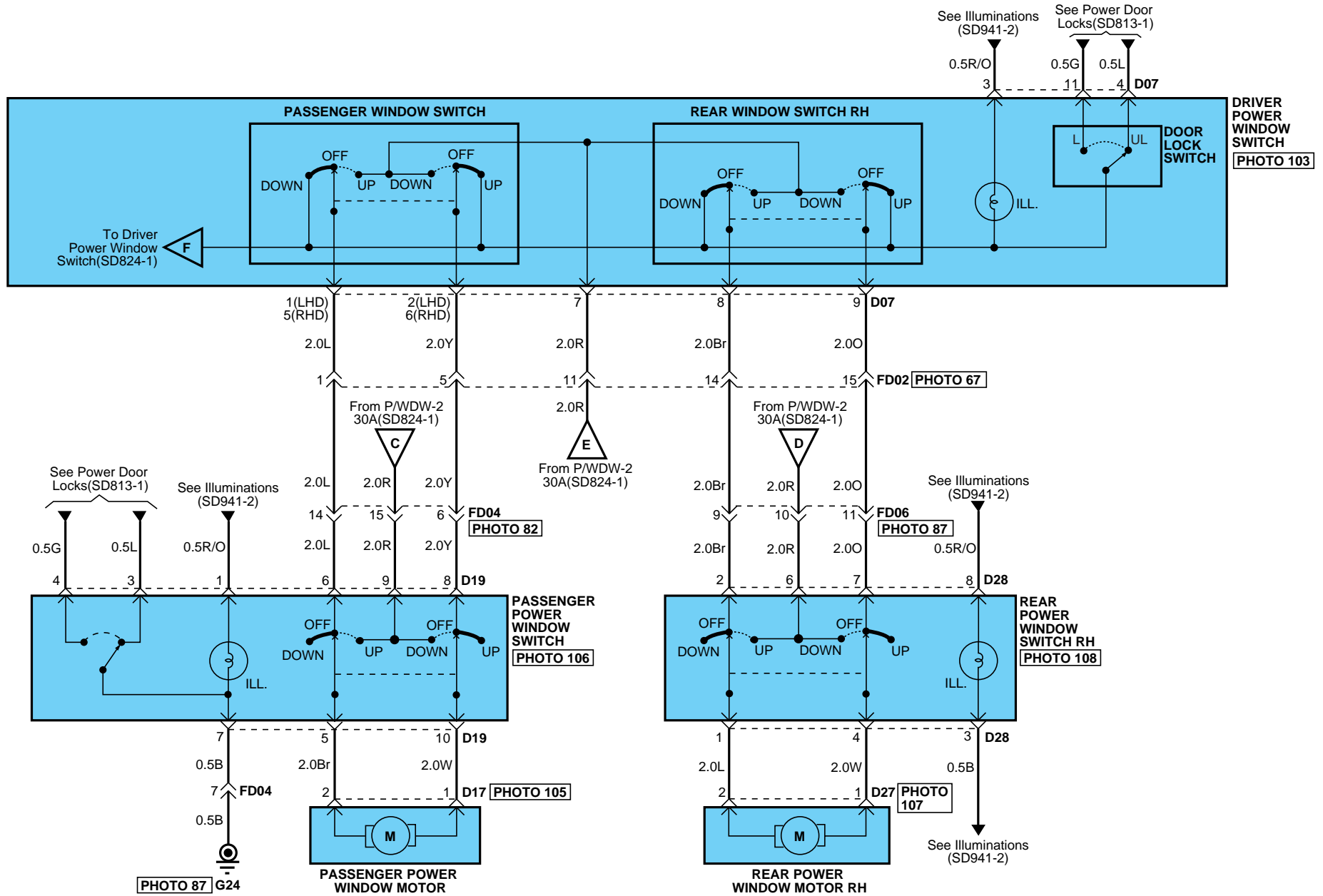

POWER WINDOWS

POWER WINDOWS (3)

SD824-3

D06

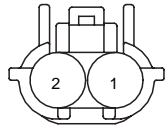

KET_SWP_02F_B

D07

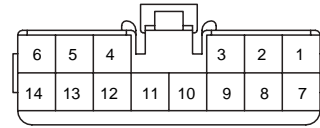

KET_090II_14F_W

D17

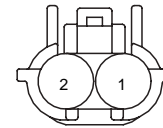

KET_SWP_02F_B

D19

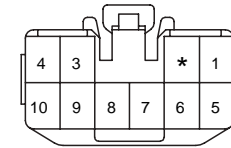

KET_090II_10F_W

D23

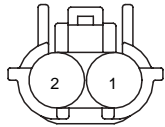

KET_SWP_02F_B

D24

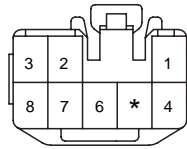

KET_090II_08F_W

D27

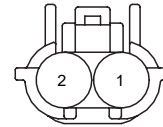

KET_SWP_02F_B

D28

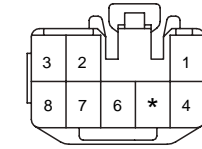

KET_SWP_08F_W

POWER WINDOWS

POWER WINDOWS (4)

SD824-4

MEMO

ELECTRO CHROME MIRROR & COMPASS SYSTEM (1)

SD851-1

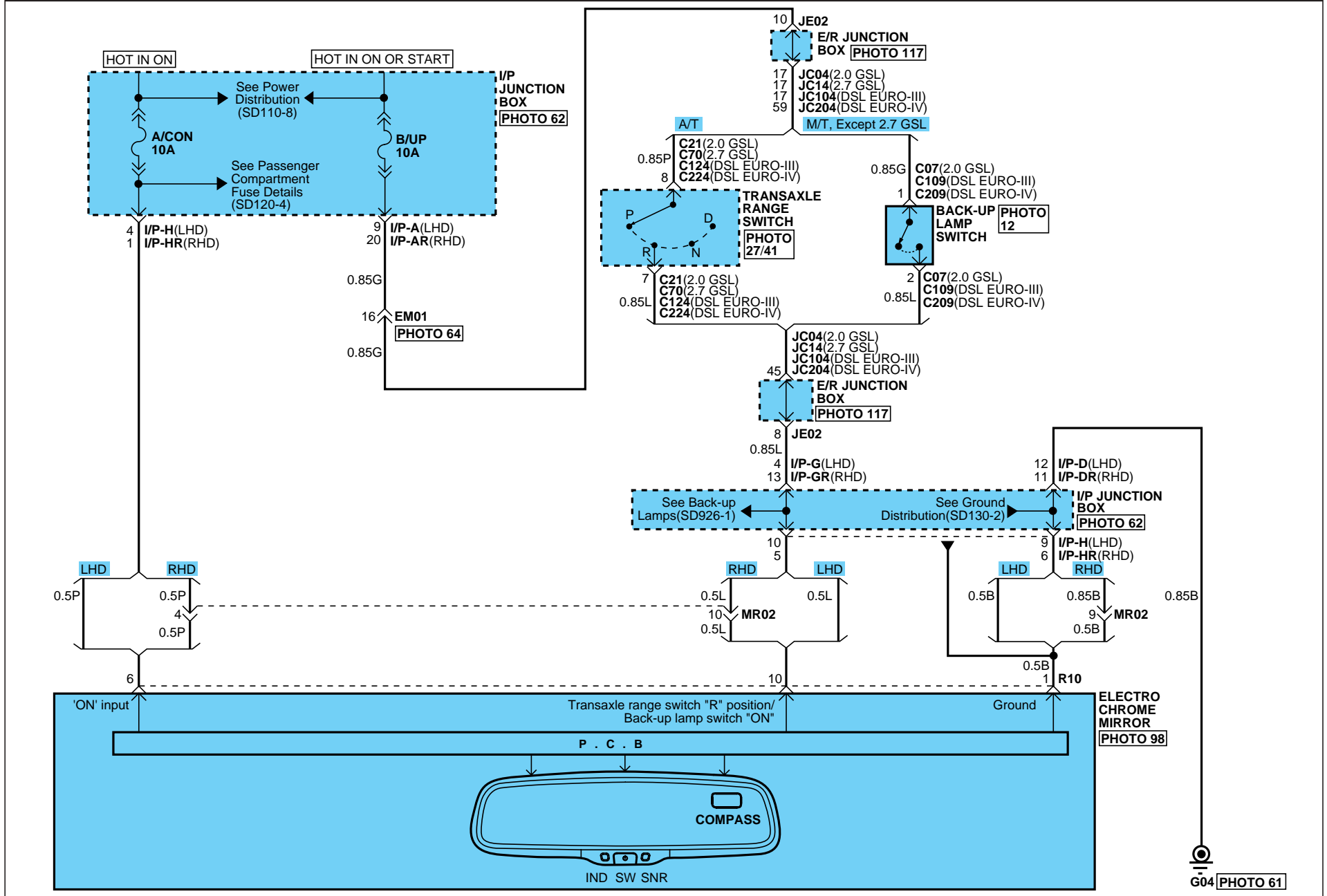

ELECTRO CHROME MIRROR & COMPASS SYSTEM

ELECTRO CHROME MIRROR & COMPASS SYSTEM (2)

SD851-2

C07/C109/C209

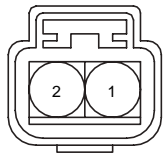

KUM_NMWP_02F_B

C21/C70/C124/C224



KET_SSD_10F_B_A

R10

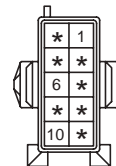

AMP_MQS_10F_B_A

BLANK

POWER OUTSIDE MIRRORS (1)

SD876-1

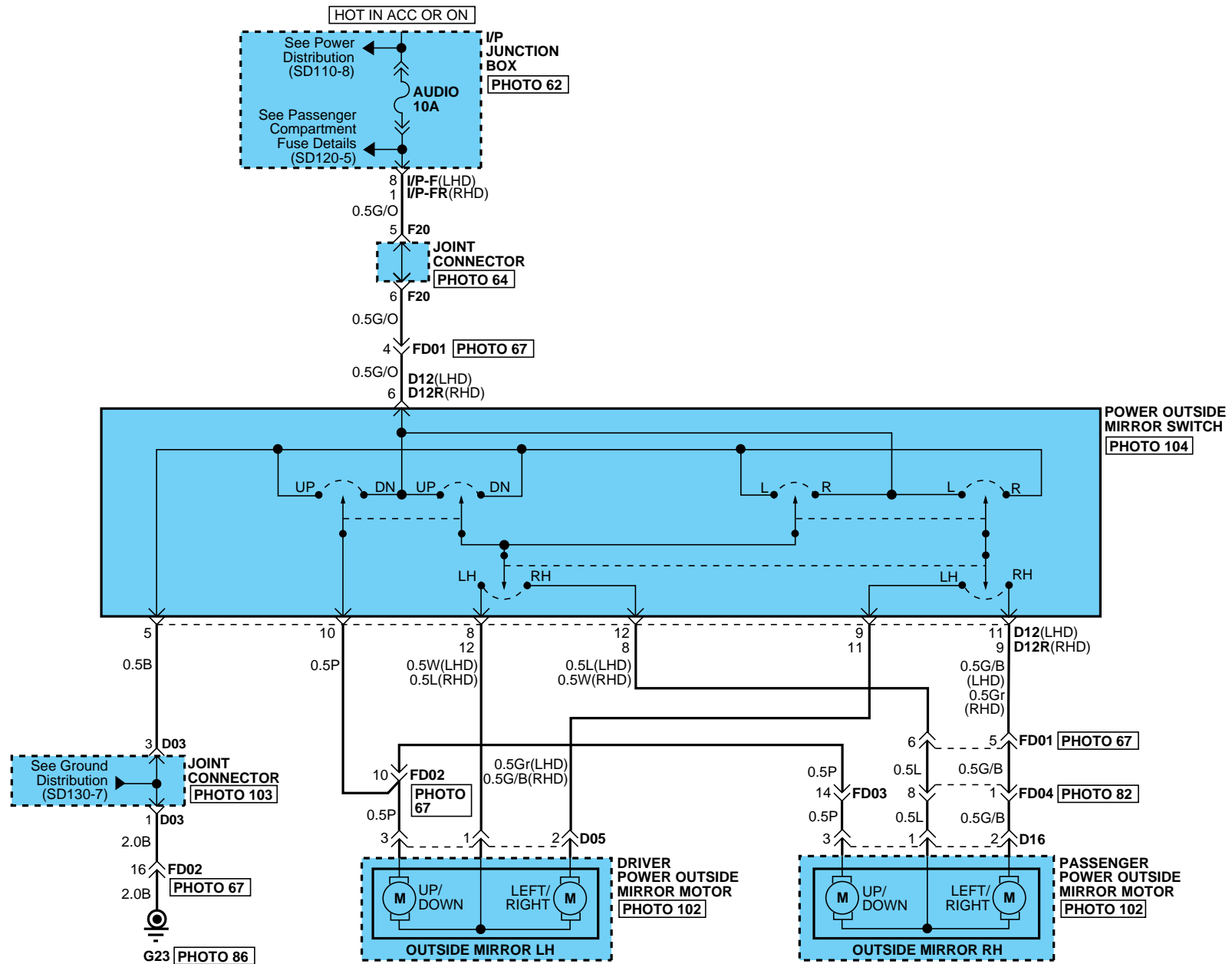

POWER OUTSIDE MIRRORS

POWER OUTSIDE MIRRORS (2)

SD876-2

D05

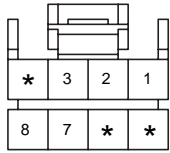

AMP_040M1_08F_B

D12/D12R

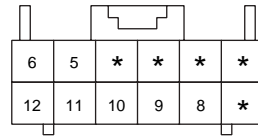

AMP_0407_12F_W_070

D16

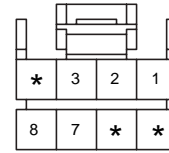

AMP_040M1_08F_B

BLANK

WINDSHIELD, REAR WINDOW & OUTSIDE MIRROR DEFOGGER SYSTEM

ECFECC0E

WINDSHIELD, REAR WINDOW & OUTSIDE MIRROR DEFOGGER SYSTEM (1)

SD879-1

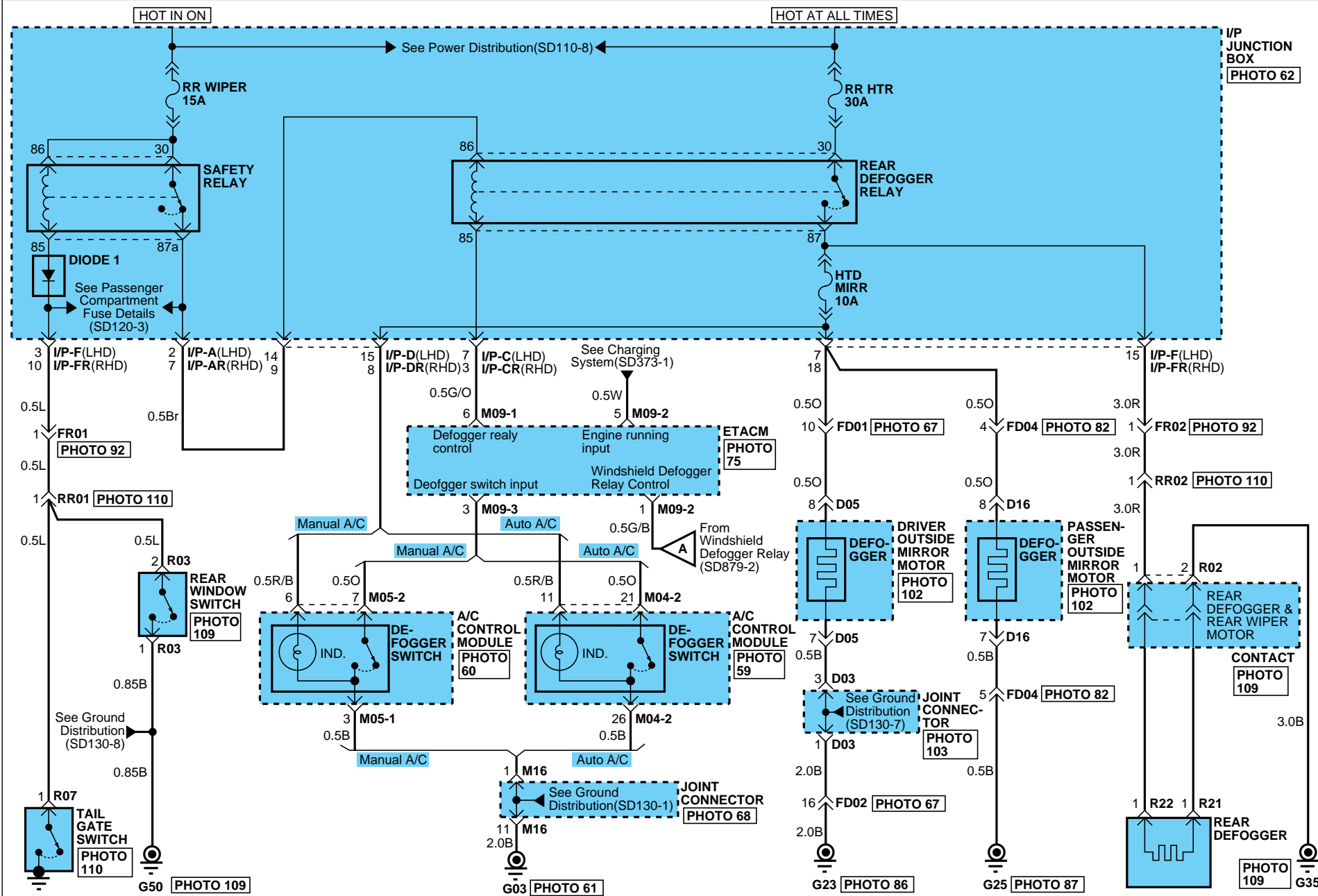

WINDSHIELD, REAR WINDOW & OUTSIDE MIRROR DEFOGGER SYSTEM

WINDSHIELD, REAR WINDOW & OUTSIDE MIRROR DEFOGGER SYSTEM (2)

SD879-2

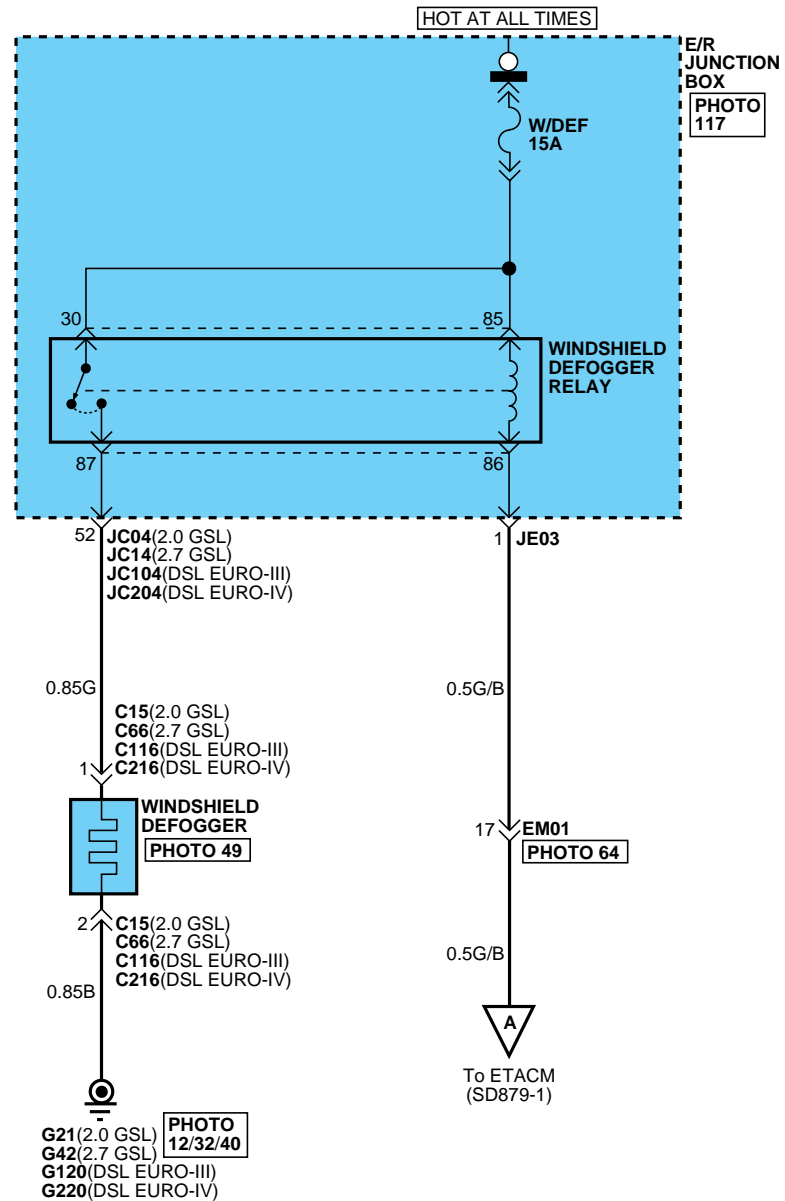

WINDSHIELD, REAR WINDOW & OUTSIDE MIRROR DEFOGGER SYSTEM

WINDSHIELD, REAR WINDOW & OUTSIDE MIRROR DEFOGGER SYSTEM (3)

SD879-3

C15/C66/C116/C216

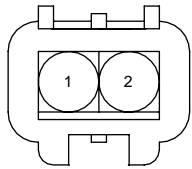

KUM_NMWP_02M_B

D05

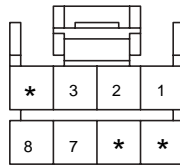

AMP_040M1_08F_B

D16

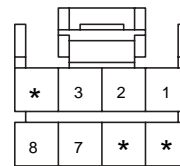

AMP_040M1_08F_B

BLANK

M04-2

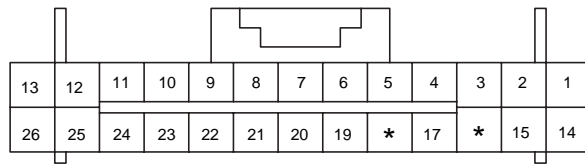

AMP_0407_26F_W_HD

M05-2

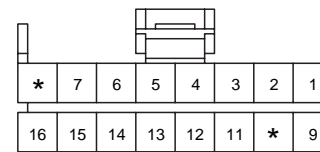

AMP_040M1_16F_B

BLANK

M09-1

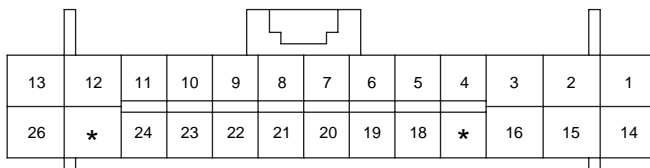

AMP_0407_26F_W_HD

M09-2

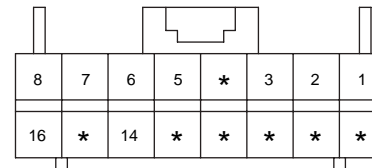

AMP_0407_16F_W_040

R02

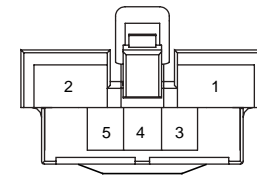

KET_2509_05F_W

R03

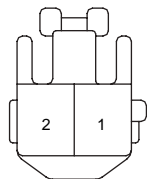

KET_090II_02F_B_R

R07



AMP_250DL_01F_B

R21/22

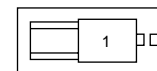

MG_630591

BLANK

WINDSHIELD, REAR WINDOW & OUTSIDE MIRROR DEFOGGER SYSTEM

WINDSHIELD, REAR WINDOW & OUTSIDE MIRROR DEFOGGER SYSTEM (4)

SD879-4

MEMO

SEAT WARMER (1)

SD889-1

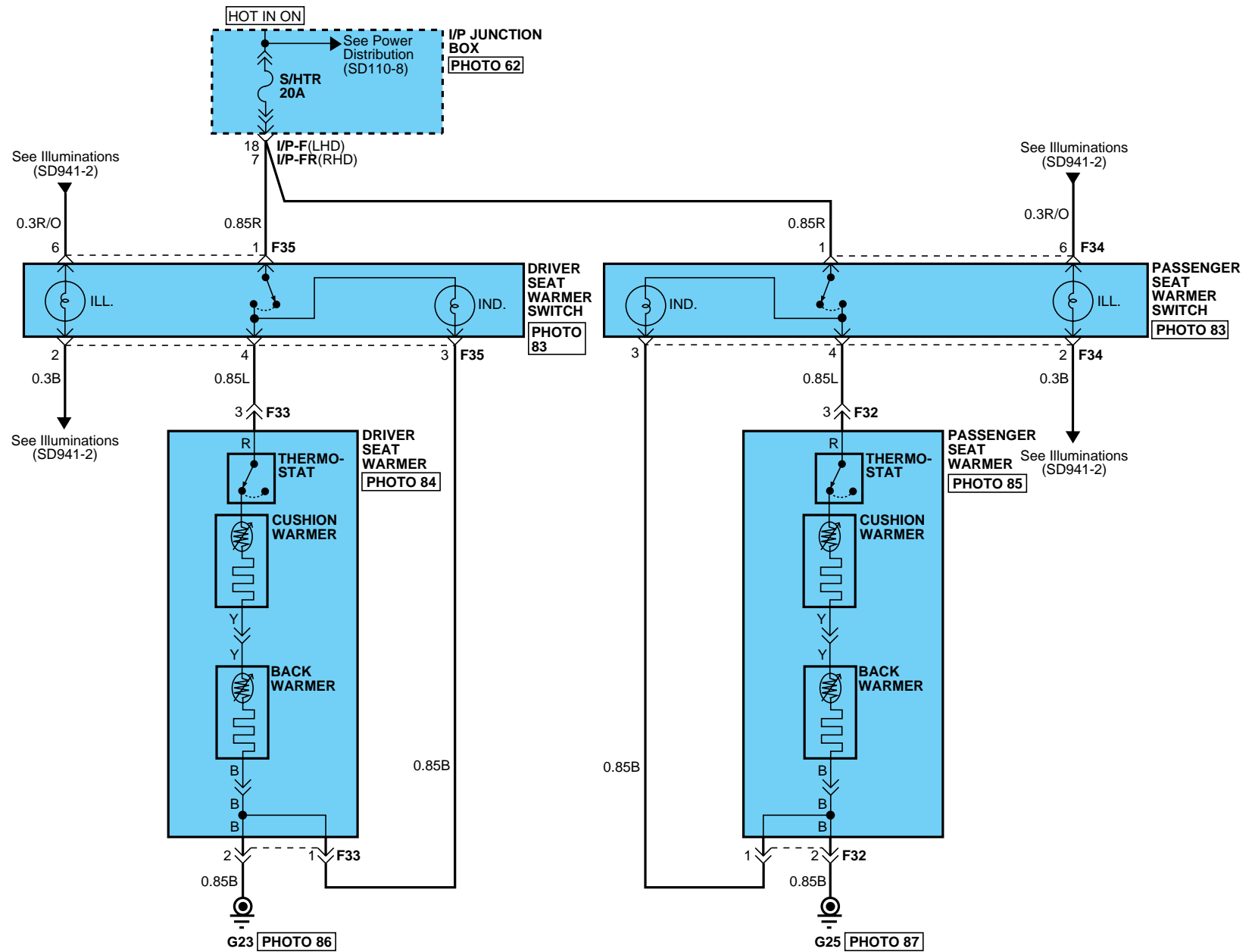

SEAT WARMER

SEAT WARMER (2)

SD889-2

F32

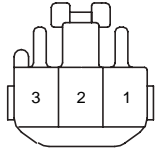

KET_090II_03F_W

F33

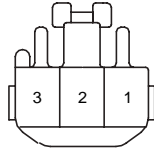

KET_090II_03F_W

F34

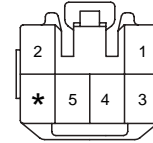

KET_090II_06F_W

F35

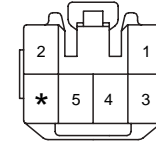

KET_090II_06F_W

HEAD LAMPS (1)

SD921-1

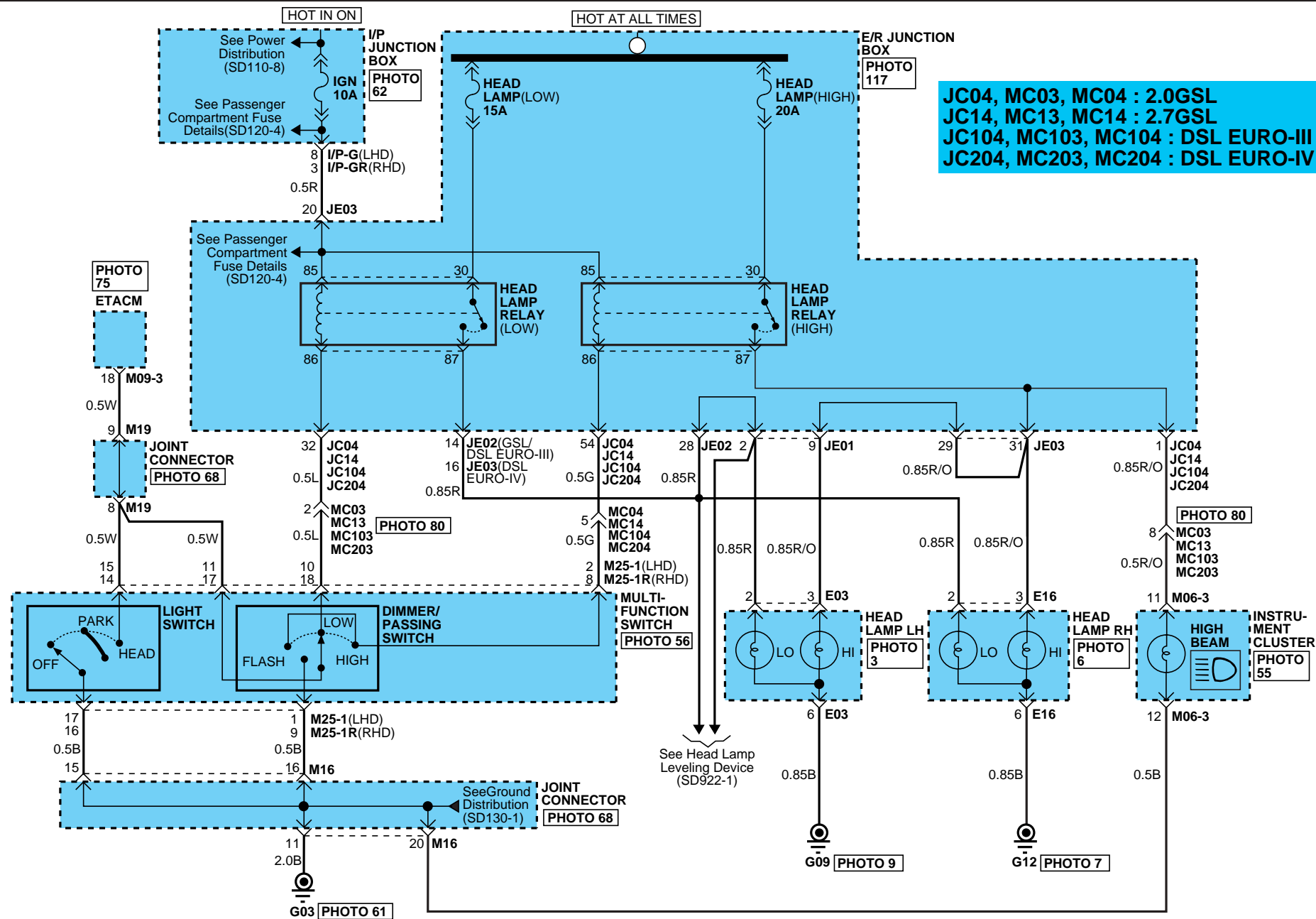

HEAD LAMPS

HEAD LAMPS (2)

SD921-2

E03

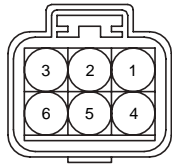

KUM_NMWP_06F_B

E16

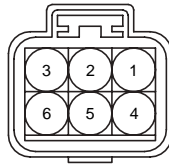

KUM_NMWP_06F_B

M06-3

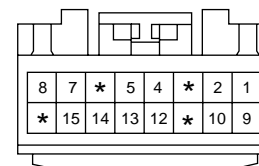

MLX_040III_16F_Gr

BLANK

M09-3

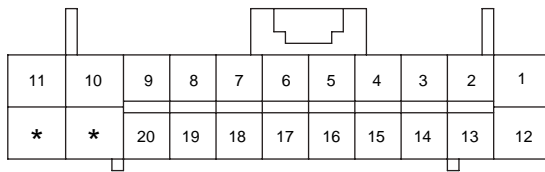

AMP_0407_22F_W_HD

M25-1

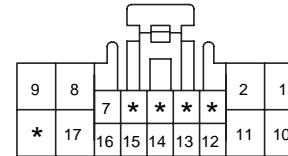

KET_0509_18F_W

M25-1R

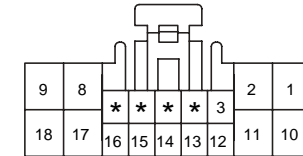

KET_0509_18F_W

HEAD LAMP LEVELING DEVICE (1)

SD922-1

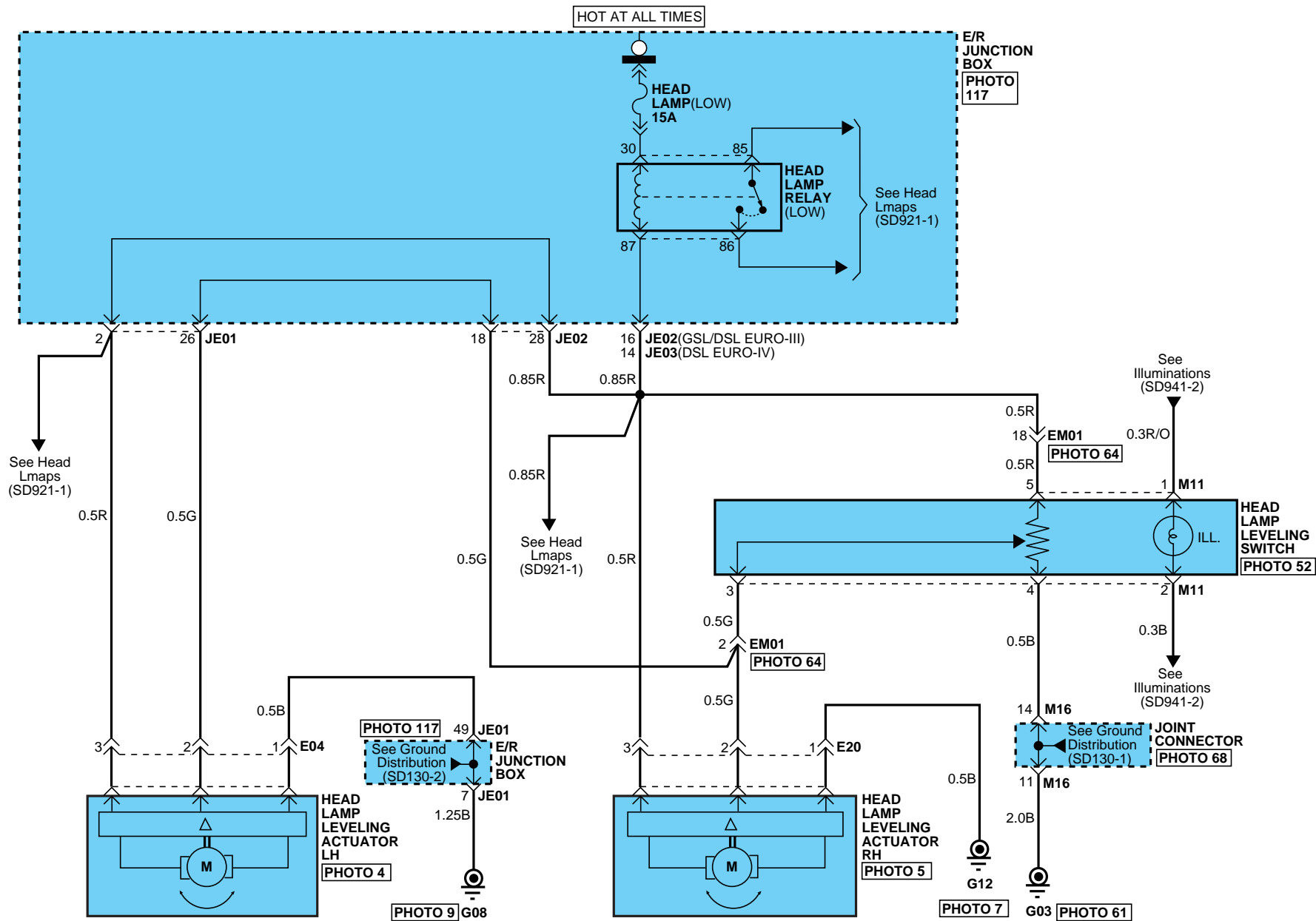

HEAD LAMP LEVELING DEVICE

HEAD LAMP LEVELING DEVICE (2)

SD922-2

E04

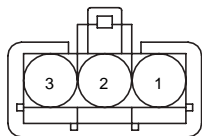

AMP_025_03F

E20

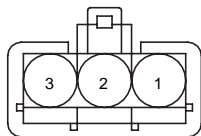

AMP_025_03F

M11

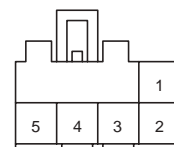

KUM_CDR_05F_W

BLANK

FRONT FOG & REAR FOG LAMPS

E8E8E99D

FRONT FOG & REAR FOG LAMPS (1)

SD924-1

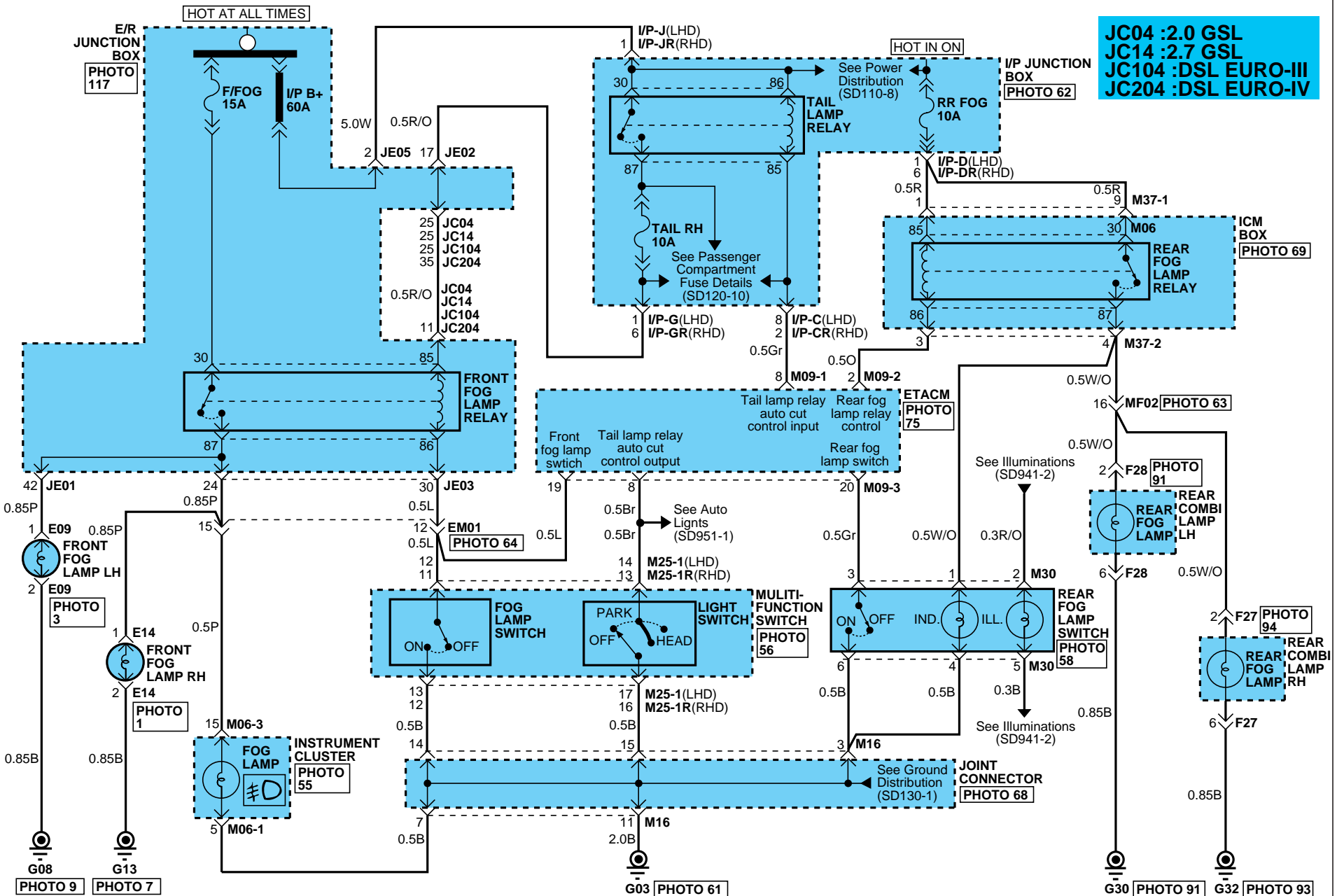

FRONT FOG & REAR FOG LAMPS

FRONT FOG & REAR FOG LAMPS (2)

SD924-2

E09

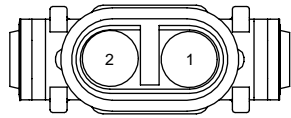

KET_110WP_02F_B

E14

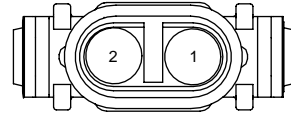

KET_110WP_02F_B

F27

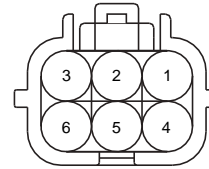

KET_SWP_06F_B

F28

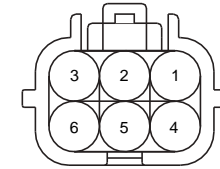

KET_SWP_06F_B

M06-3

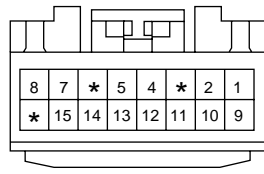

MLX_040III_16F_Gr

M09-2

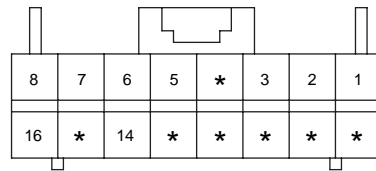

AMP_0407_16F_W_040

M09-3

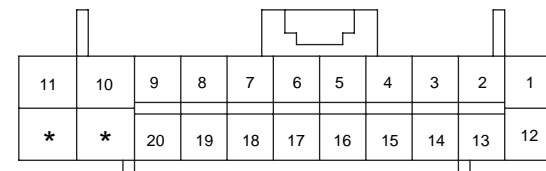

AMP_0407_22F_W_HD

M25-1

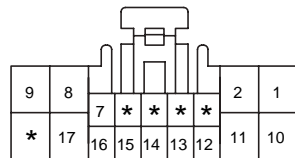

KET_0509_18F_W

M25-1R

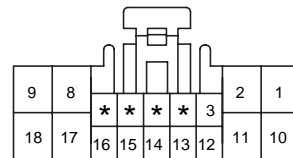

KET_0509_18F_W

M30

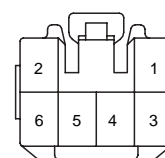

KET_090II_06F_W

BLANK

TURN & HAZARD LAMPS (1)

SD925-1

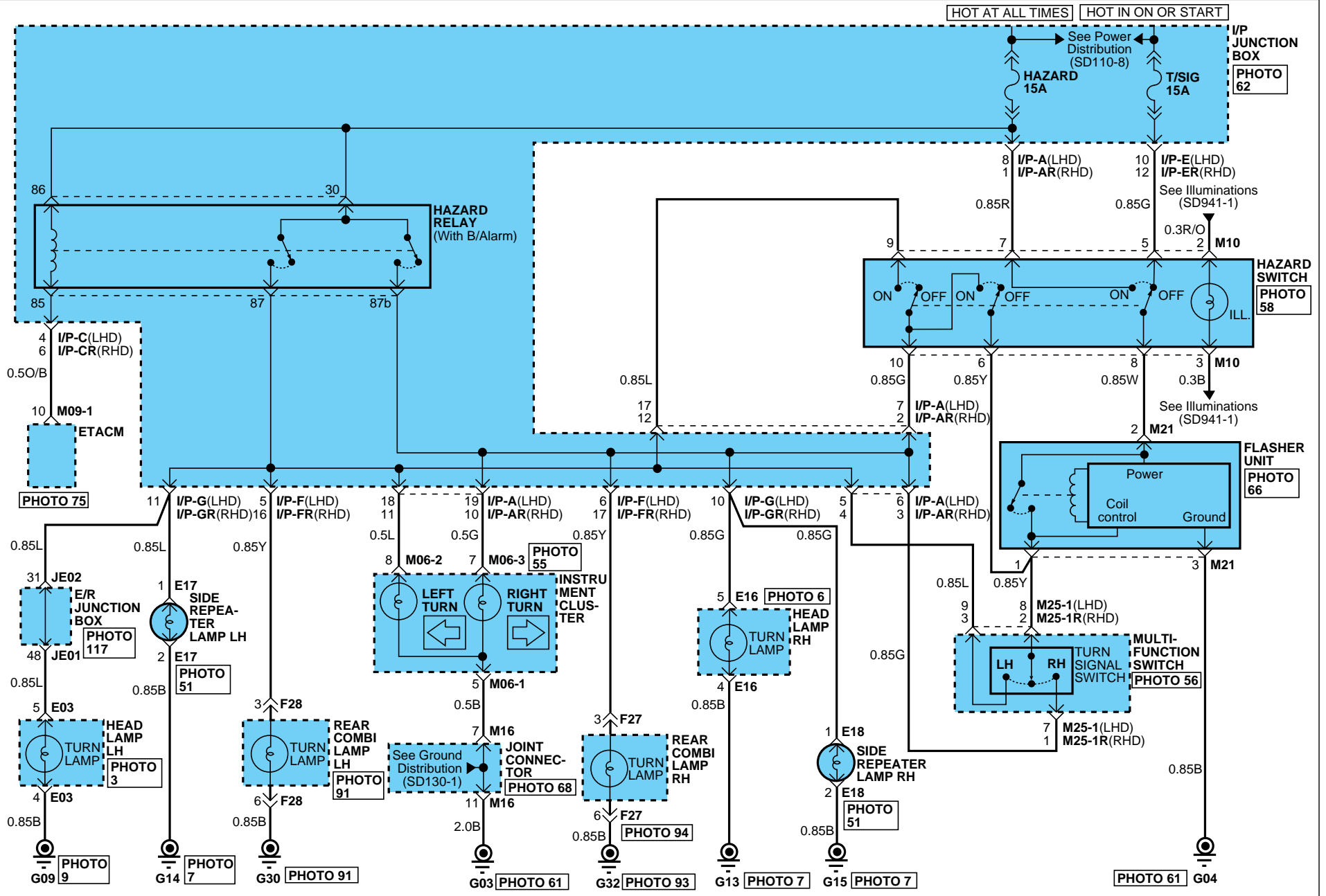

TURN & HAZARD LAMPS

TURN & HAZARD LAMPS (2)

SD925-2

E03

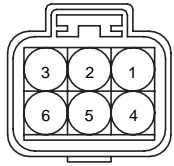

KUM_NMWP_06F_B

E16

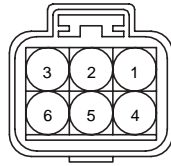

KUM_NMWP_06F_B

E17

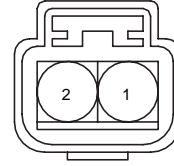

KUM_NMWP_02F_Gr

E18

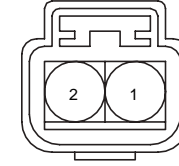

KUM_NMWP_02F_Gr

F27

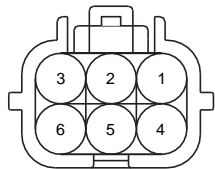

KET_SWP_06F_B

F28

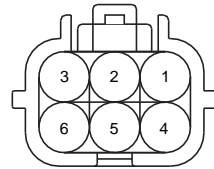

KET_SWP_06F_B

M06-2

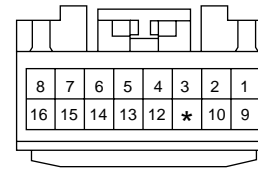

MLX_040III_16F_Gr

M06-3

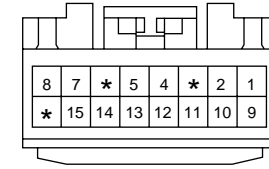

MLX_040III_16F_Gr

M09-1

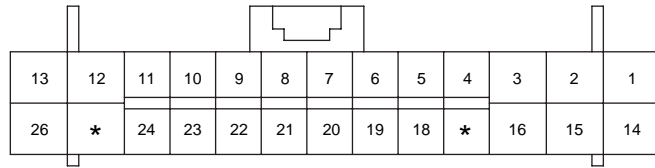

AMP_0407_26F_W_HD

M10

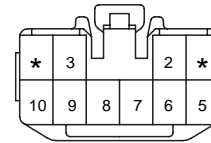

KET_090II_10F_W

M21

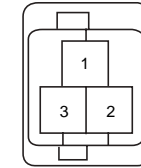

AMP_250_03F_B_RLY

M25-1

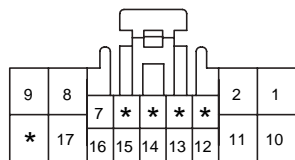

KET_0509_18F_W

M25-1R

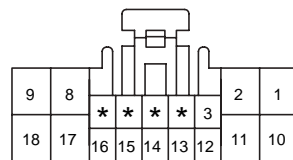

KET_0509_18F_W

BLANK

BLANK

BACK-UP LAMPS (1)

SD926-1

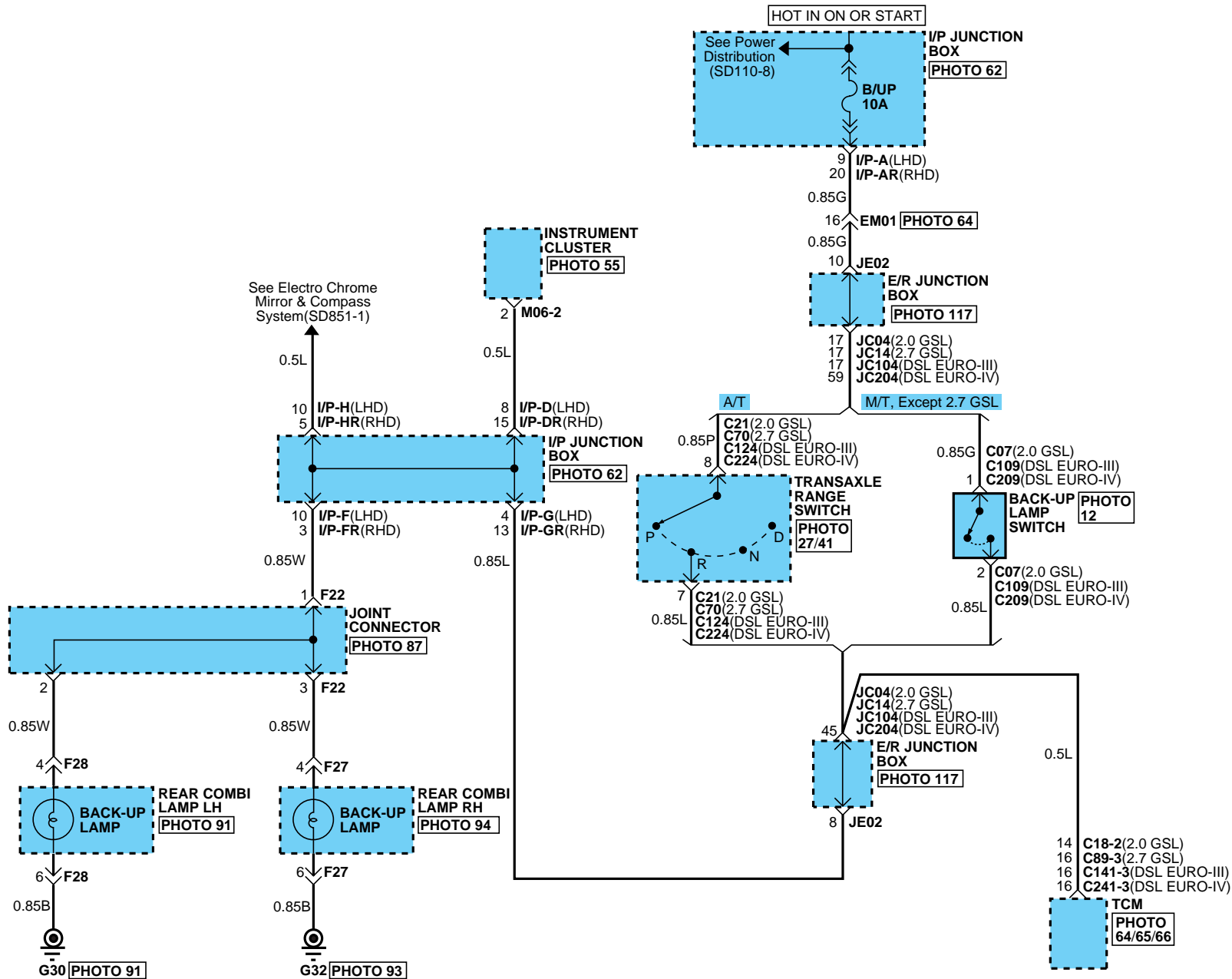

BACK-UP LAMPS

BACK-UP LAMPS (2)

SD926-2

C07/C109/C209

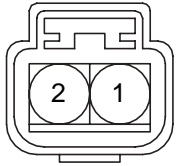

KUM_NMWP_02F_B

C21/C70/C124/C224



KET_SSD_10F_B_A

F27

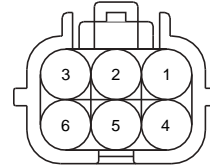

KET_SWP_06F_B

F28

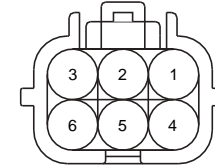

KET_SWP_06F_B

STOP LAMPS (1)

SD927-1

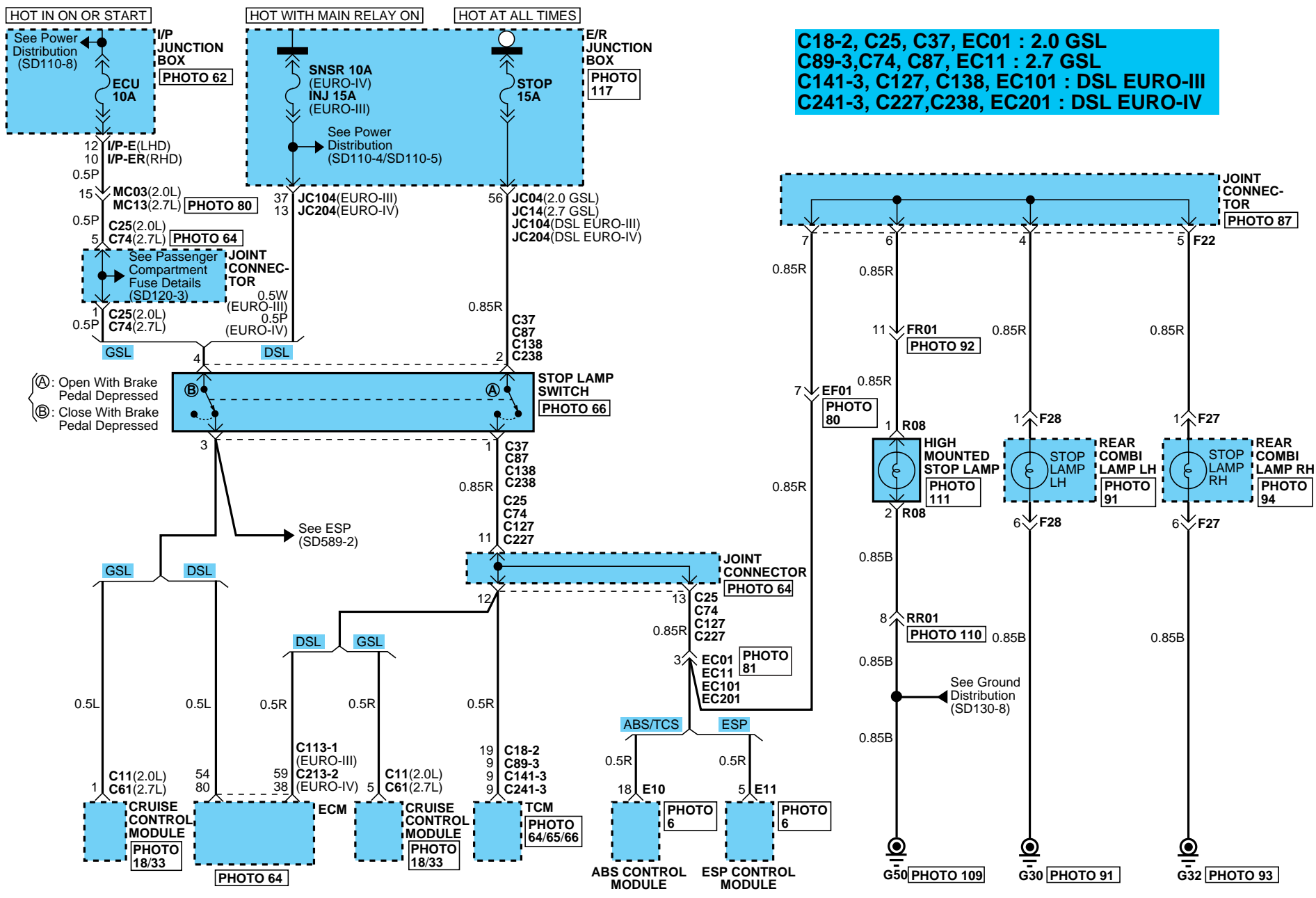

STOP LAMPS

STOP LAMPS (2)

SD927-2

C11/C61

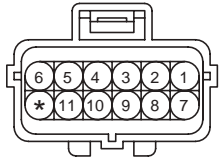

AMP_EJWP_12F_B

C37/C87/C138/C238

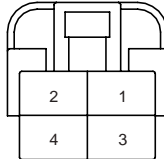

KET_250DL_04F_W

F27

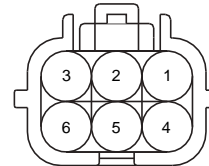

KET_SWP_06F_B

F28

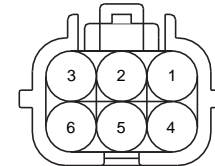

KET_SWP_06F_B

R08

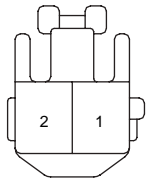

KET_090II_02F_B_R

BLANK

BLANK

BLANK

TAIL, PARKING & LICENSE LAMPS (1)

SD928-1

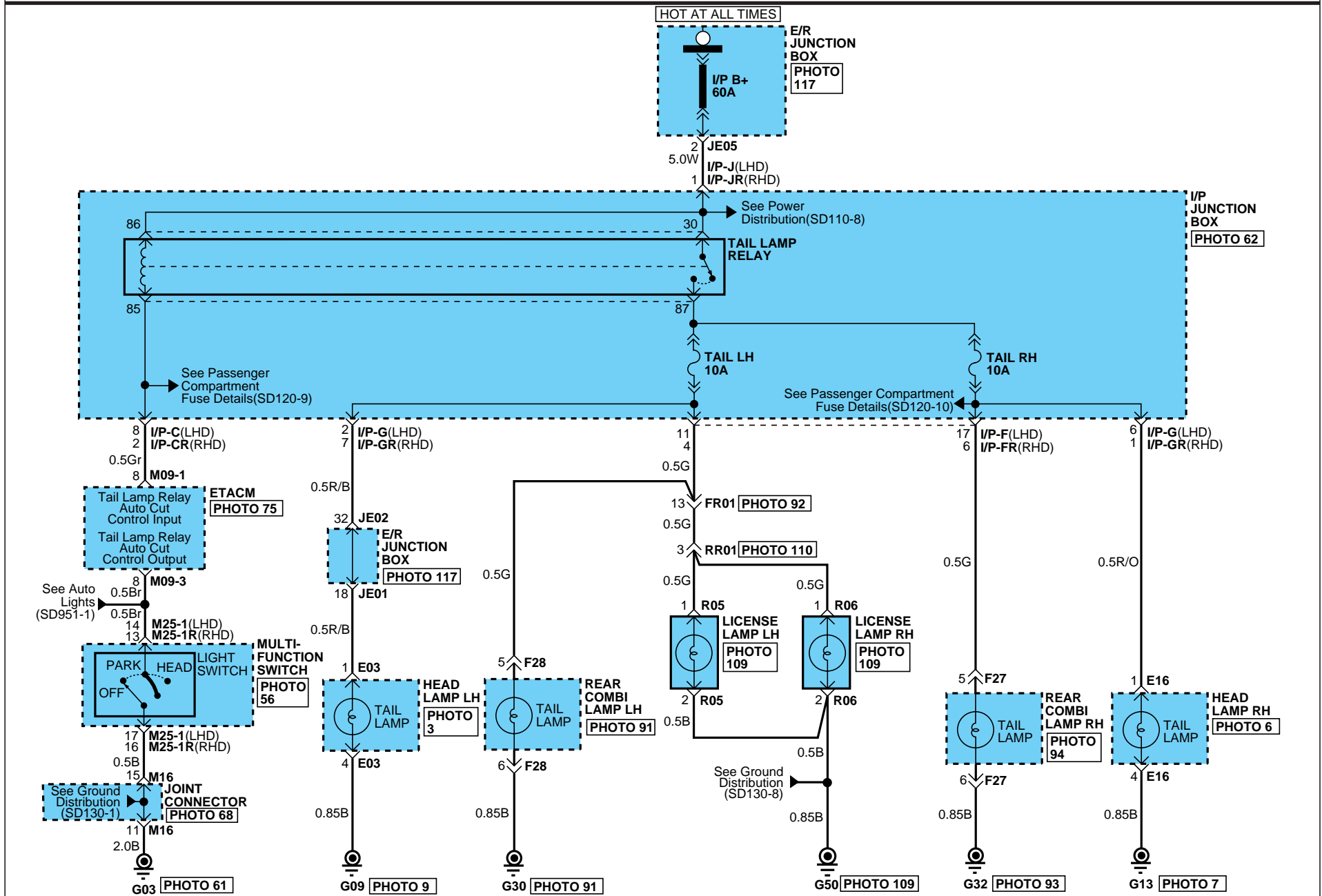

TAIL, PARKING & LICENSE LAMPS

TAIL, PARKING & LICENSE LAMPS (2)

SD928-2

E03

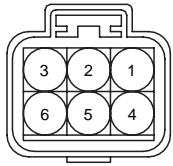

KUM_NMWP_06F_B

E16

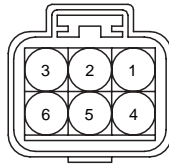

KUM_NMWP_06F_B

F27

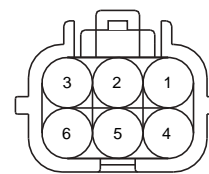

KET_SWP_06F_B

F28

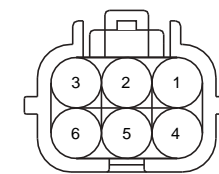

KET_SWP_06F_B

M09-1

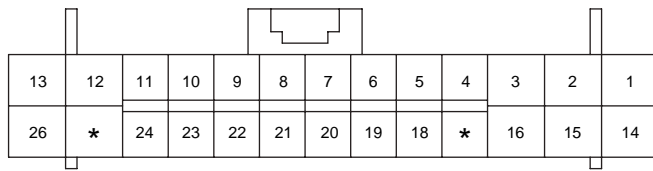

AMP_0407_26F_W_HD

M09-3

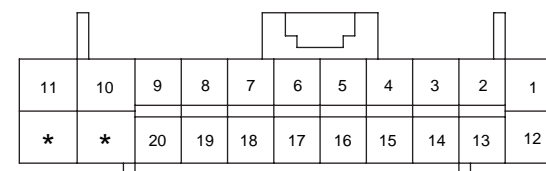

AMP_0407_22F_W_HD

M25-1

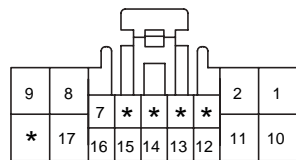

KET_0509_18F_W

M25-1R

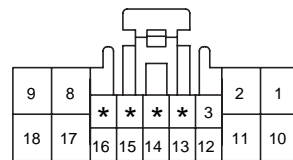

KET_0509_18F_W

R05

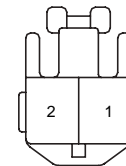

KET_090II_02F_Gr_T

R06

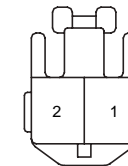

KET_090II_02F_Gr_T

COURTESY & TAIL GATE LAMPS (1)

SD929-1

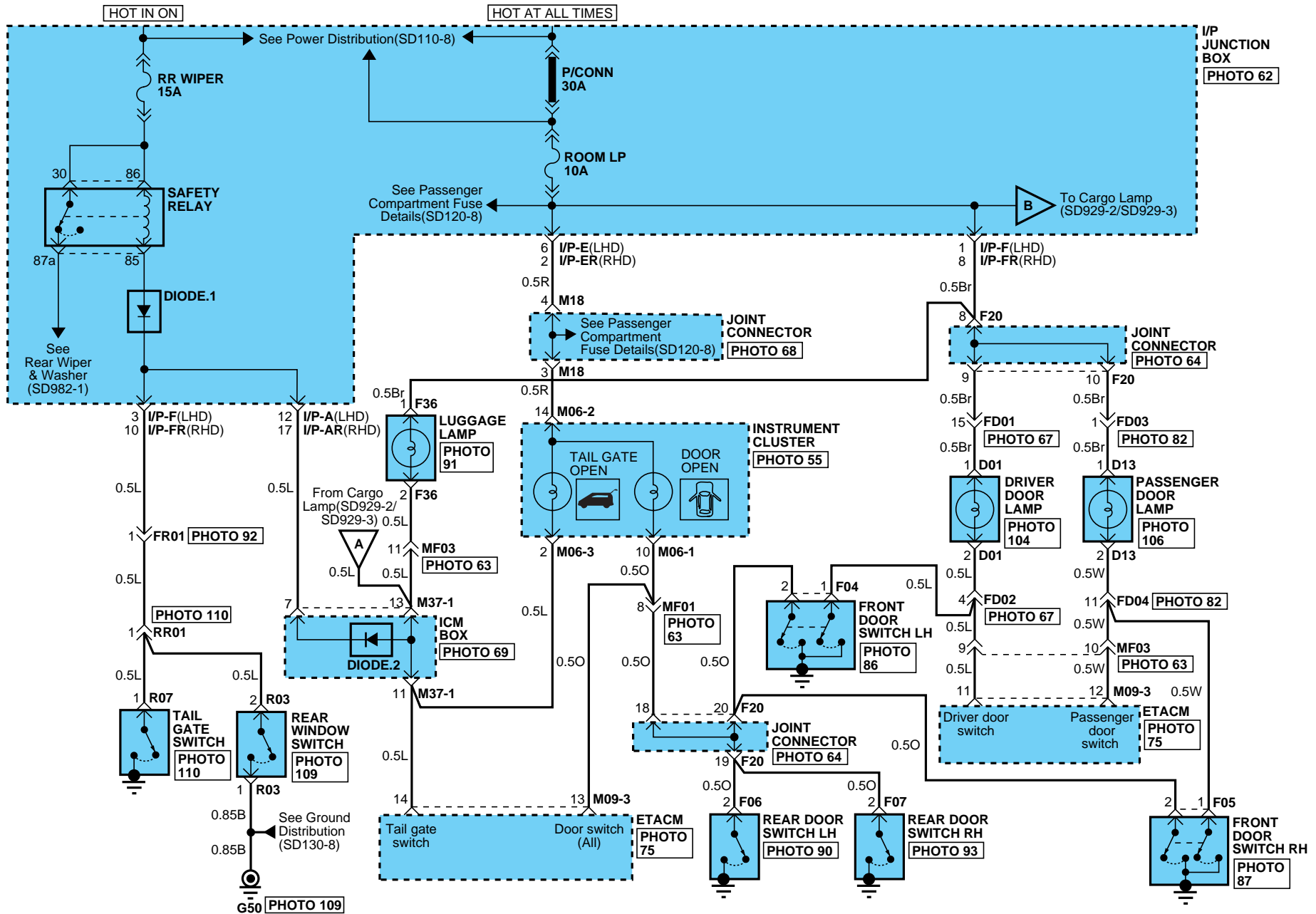

COURTESY & TAIL GATE LAMPS

COURTESY & TAIL GATE LAMPS (2)

SD929-2

LHD

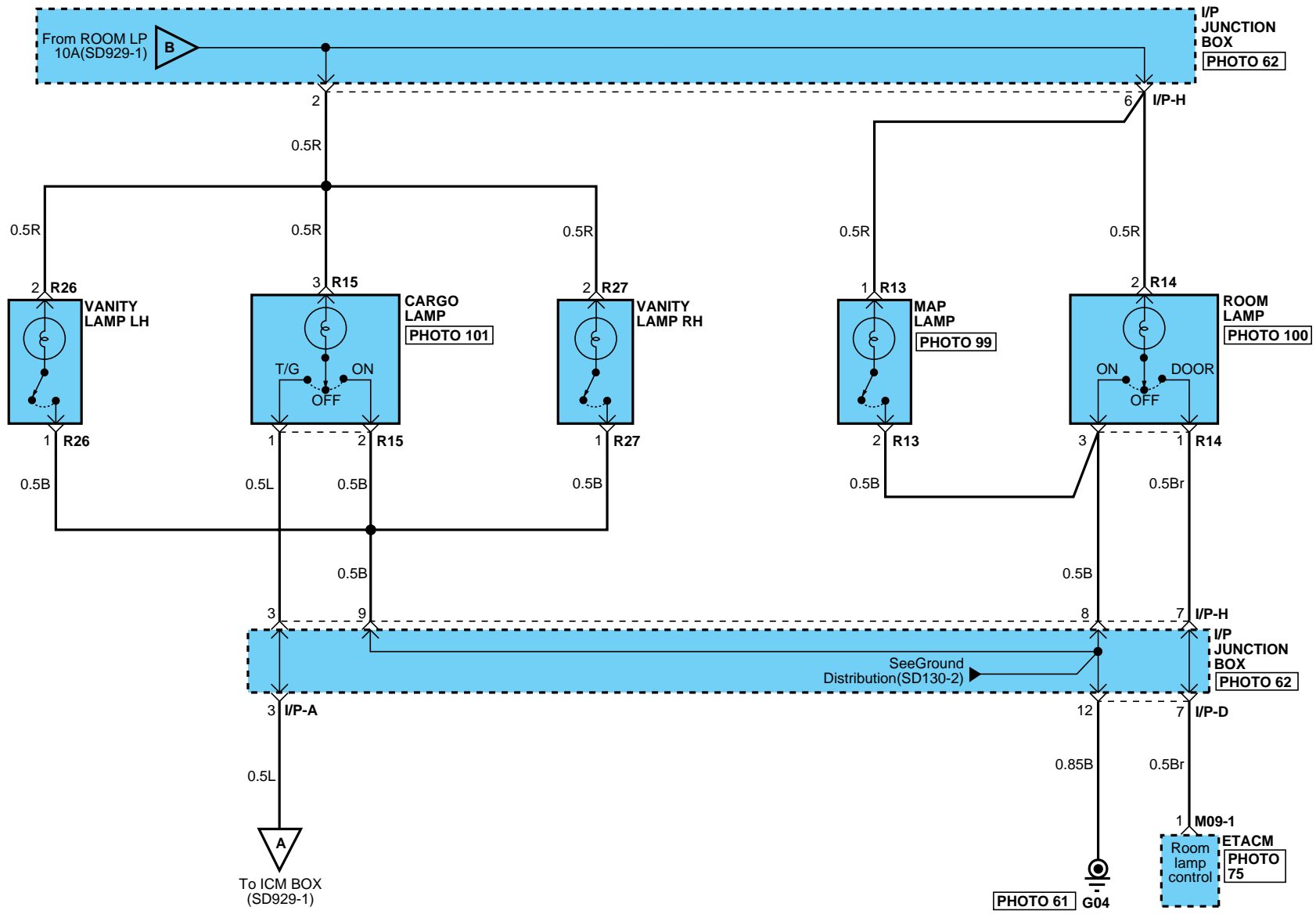

COURTESY & TAIL GATE LAMPS

COURTESY & TAIL GATE LAMPS (3)

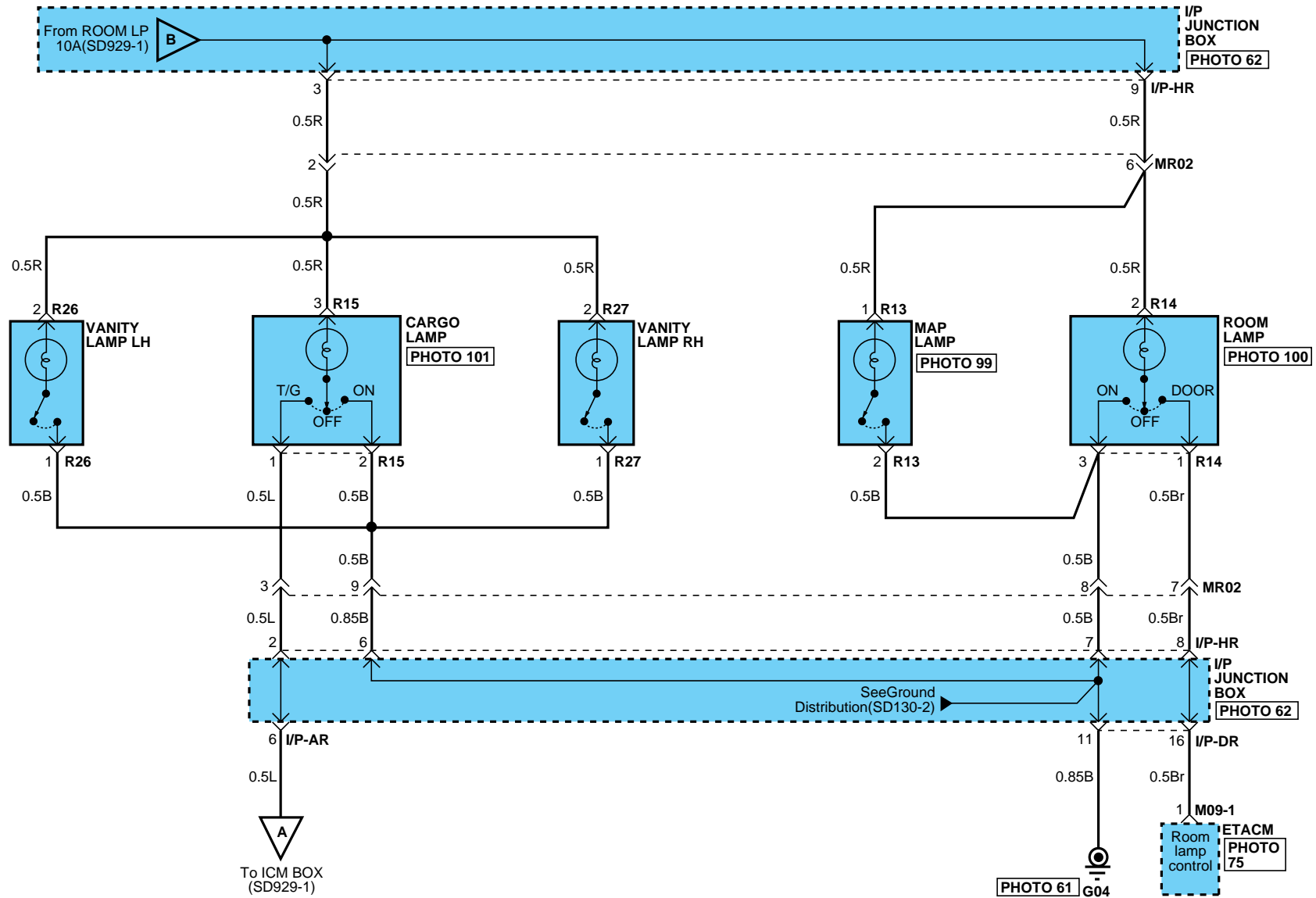

SD929-3

RHD

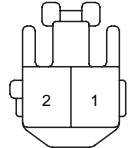
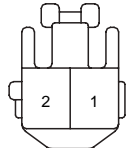
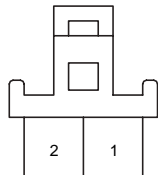
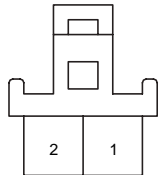
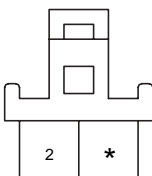
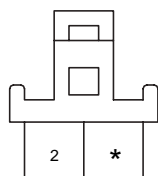
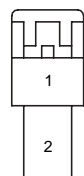
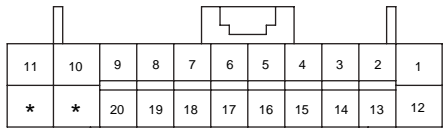
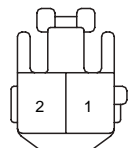

COURTESY & TAIL GATE LAMPS

COURTESY & TAIL GATE LAMPS (4) SD929-4

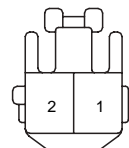
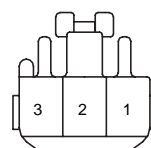
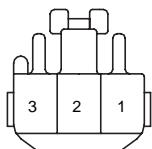
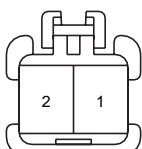
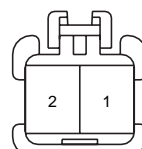
<p>D01</p>  <p>KET_090II_02F_W_L</p>	<p>D13</p>  <p>KET_090II_02F_W_L</p>	<p>F04</p>  <p>KET_070_02F_W</p>	<p>F05</p>  <p>KET_070_02F_W</p>
<p>F06</p>  <p>KET_070_02F_W</p>	<p>F07</p>  <p>KET_070_02F_W</p>	<p>F36</p>  <p>KUM_DSD_02F_B</p>	<p>M09-3</p>  <p>AMP_0407_22F_W_HD</p>
<p>R03</p>  <p>KET_090II_02F_B_R</p>	<p>R07</p>  <p>AMP_250DL_01F_B</p>	<p>R13</p>  <p>KET_090II_02F_W_L</p>	<p>R14</p>  <p>KET_090II_03F_W</p>
<p>R15</p>  <p>KET_090II_03F_W</p>	<p>R26</p>  <p>KET_09_02F_W_PBT</p>	<p>R27</p>  <p>KET_09_02F_W_PBT</p>	<p>BLANK</p>

INDICATORS & GAUGES (1)

SD940-1

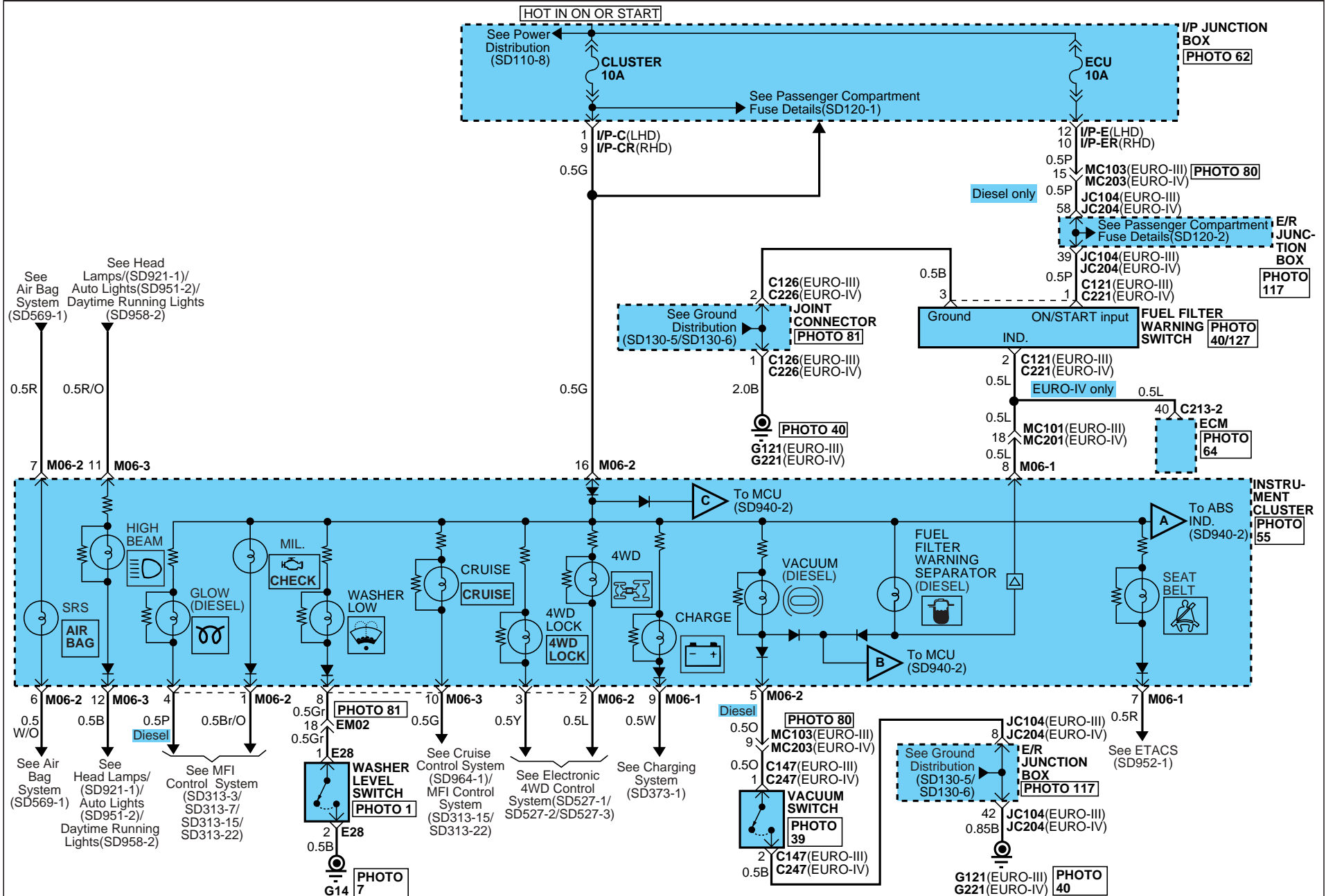

INDICATORS & GAUGES

INDICATORS & GAUGES (2)

SD940-2

C05, C31, MC02 : 2.0 GSL
 C59, C82, MC12 : 2.7 GSL
 C107, C131, MC102 : DSL EURO-III
 C201, C231, MC202 : DSL EURO-IV

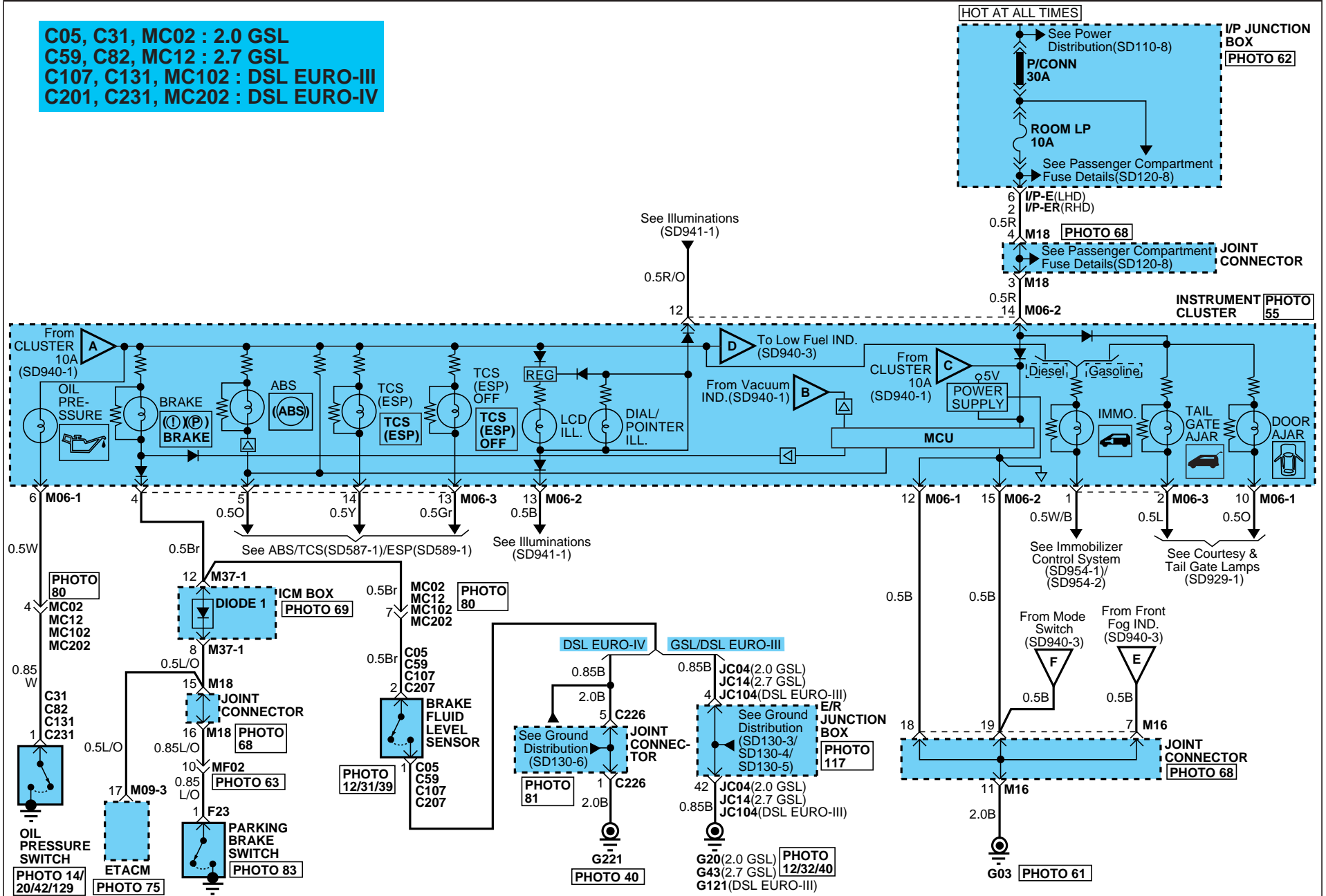



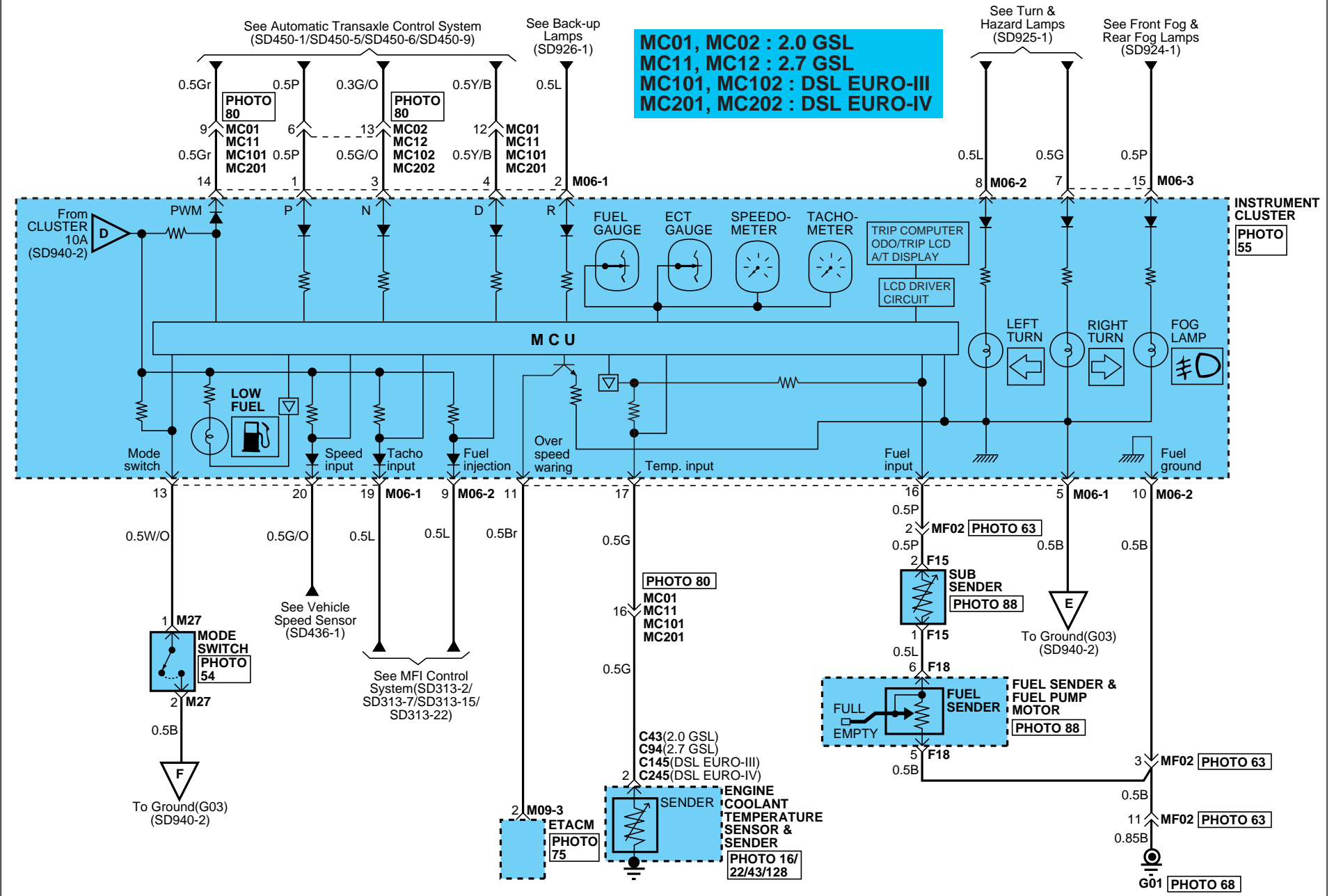

INDICATORS & GAUGES

INDICATORS & GAUGES (3)

SD940-3

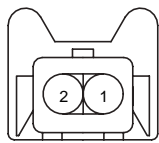
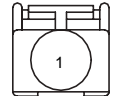
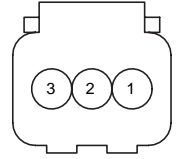

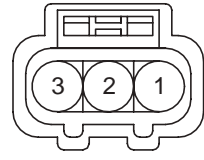
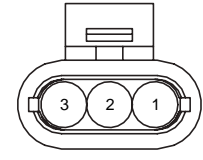
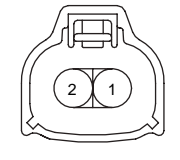
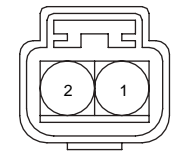
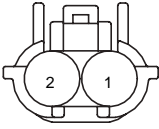
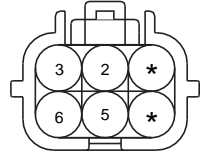
INDICATORS & GAUGES

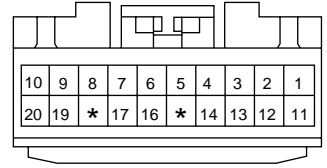
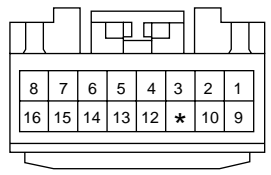
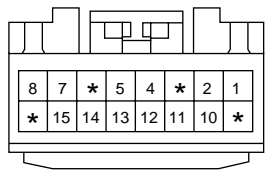
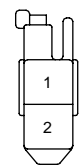
INDICATORS & GAUGES (4)			SD940-4
<p>C05/C59/C107/C207</p>  <p>AMP_JPT_02F_B</p>	<p>C31</p>  <p>AMP_PLM2_01F_B</p>	<p>C43/C145/C245</p>  <p>KUM_WTS_03F_B</p>	<p>C82/C131/C231</p>  <p>KUM_NMWP_01F_B</p>
<p>C94</p>  <p>KUM_62Z_03F_B_WTS</p>	<p>C121/C221</p>  <p>AMP_1.5WP_03F_W</p>	<p>C147/C247</p>  <p>KET_090WP_02F_B</p>	<p>E28</p>  <p>KUM_NMWP_02F_B</p>
<p>F15</p>  <p>KET_SWP_02F_B</p>	<p>F18</p>  <p>KET_SWP_06F_B</p>	<p>F23</p>  <p>AMP_250DL_01F_B</p>	<p>M06-1</p>  <p>MLX_040III_20F_Gr</p>
<p>M06-2</p>  <p>MLX_040III_16F_Gr</p>	<p>M06-3</p>  <p>MLX_040III_16F_Gr</p>	<p>M27</p>  <p>KET_090II_02F_W_SPK</p>	<p>BLANK</p>

ILLUMINATIONS (1)

SD941-1

C17, EC01, MC02 : 2.0 GSL
 C65, EC11, MC12 : 2.7 GSL
 C112, EC101, MC102 : DSL EURO-III
 C212, EC201, MC202 : DSL EURO-IV

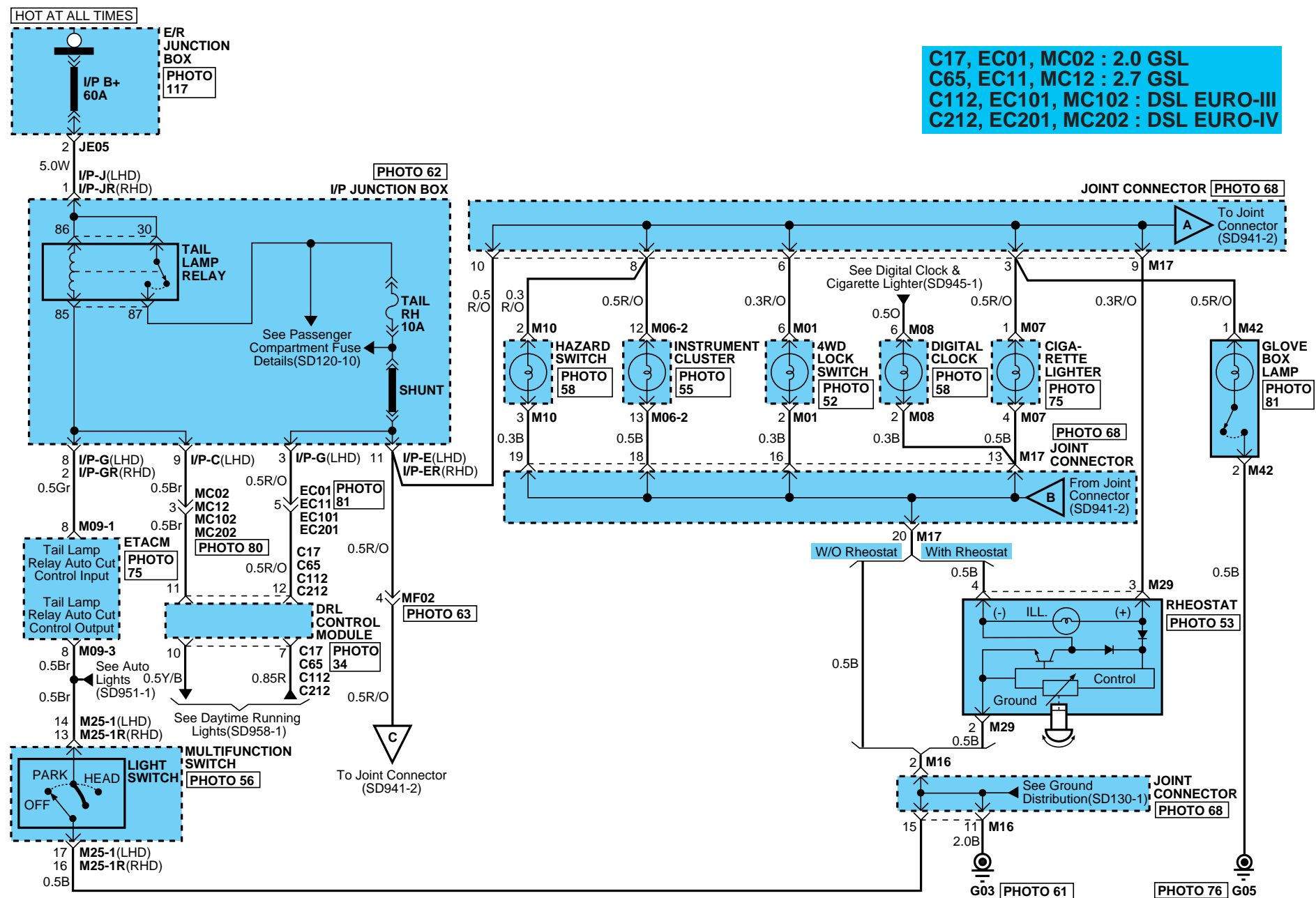

ILLUMINATIONS

ILLUMINATIONS (2)

SD941-2

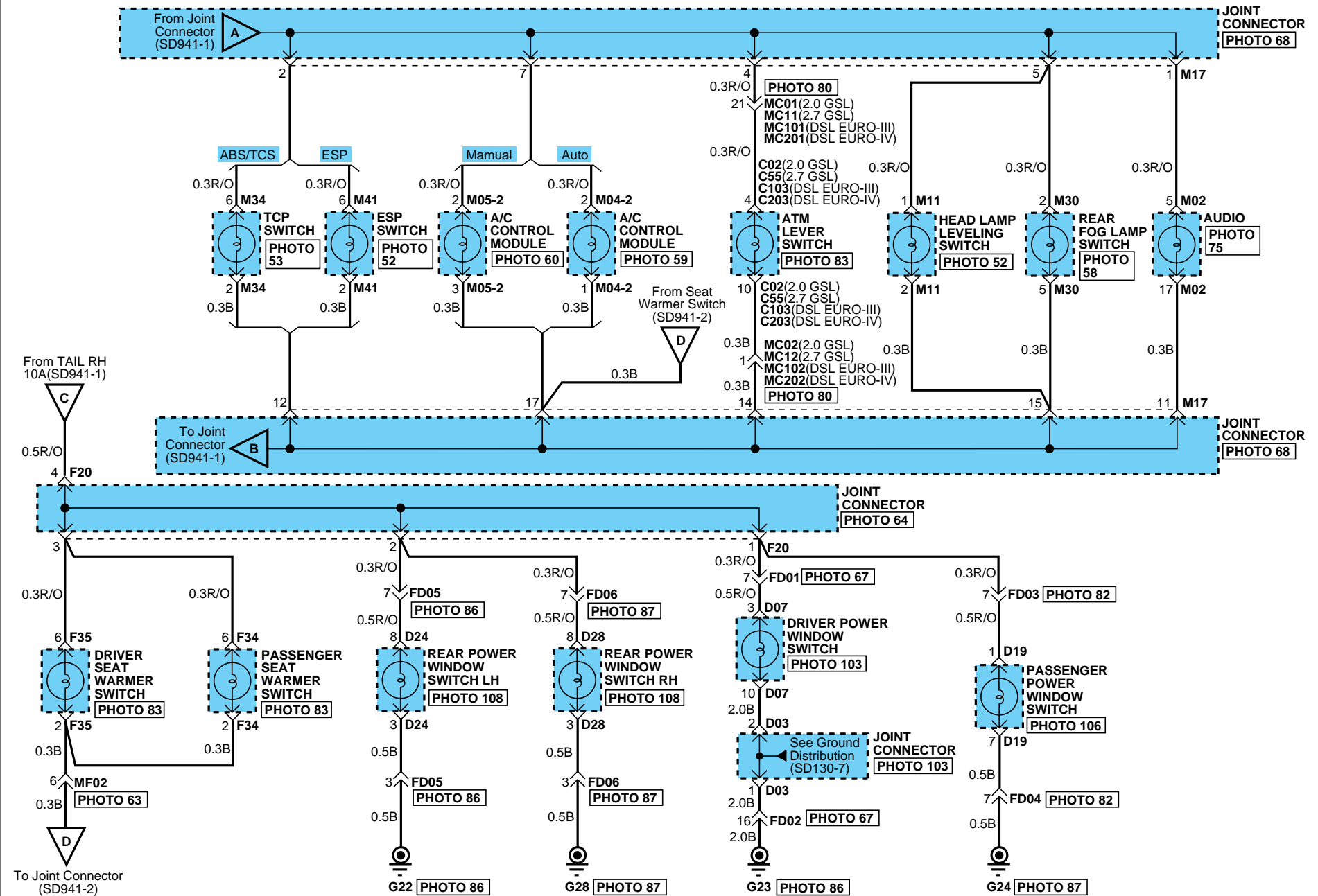

ILLUMINATIONS

ILLUMINATIONS (3)			SD941-3
<p>C02/C55/C103/C203</p> <p>KET_090II_10F_W</p>	<p>C17/C65/C112/C212</p> <p>KET_1809WP_12F_Gr</p>	<p>D07</p> <p>KET_090II_14F_W</p>	<p>D19</p> <p>KET_090II_10F_W</p>
<p>D24/D28</p> <p>KET_090II_08F_W</p>	<p>F34/F35</p> <p>KET_090II_06F_L</p>	<p>M01</p> <p>KET_090II_06F_L</p>	<p>M02</p> <p>KET_0409_24F_W</p>
<p>M04-2</p> <p>AMP_0407_26F_W_HD</p>		<p>M05-2</p> <p>AMP_040M1_16F_B</p>	<p>M06-2</p> <p>MLX_040III_16F_Gr</p>
<p>M07</p> <p>AMP_090III_04F_W</p>	<p>M08</p> <p>MLX_165_06F_W</p>	<p>M10</p> <p>KET_090II_10F_W</p>	<p>M11</p> <p>KUM_CDR_05F_W</p>
<p>M25-1</p> <p>KET_0509_18F_W</p>	<p>M25-1R</p> <p>KET_0509_18F_W</p>	<p>M29</p> <p>KET_PA_05F_W</p>	<p>M30</p> <p>KET_090II_06F_W</p>

ILLUMINATIONS

ILLUMINATIONS (4)

SD941-4

M34

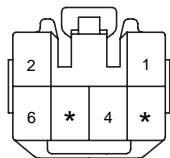

KET_090II_06F_W

M41

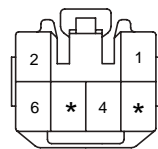

KET_090II_06F_W

M42

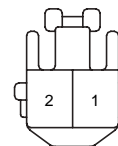

KET_090II_02F_W_L

BLANK

DIGITAL CLOCK & CIGARETTE LIGHTER (POWER OUTLET) (1)

SD945-1

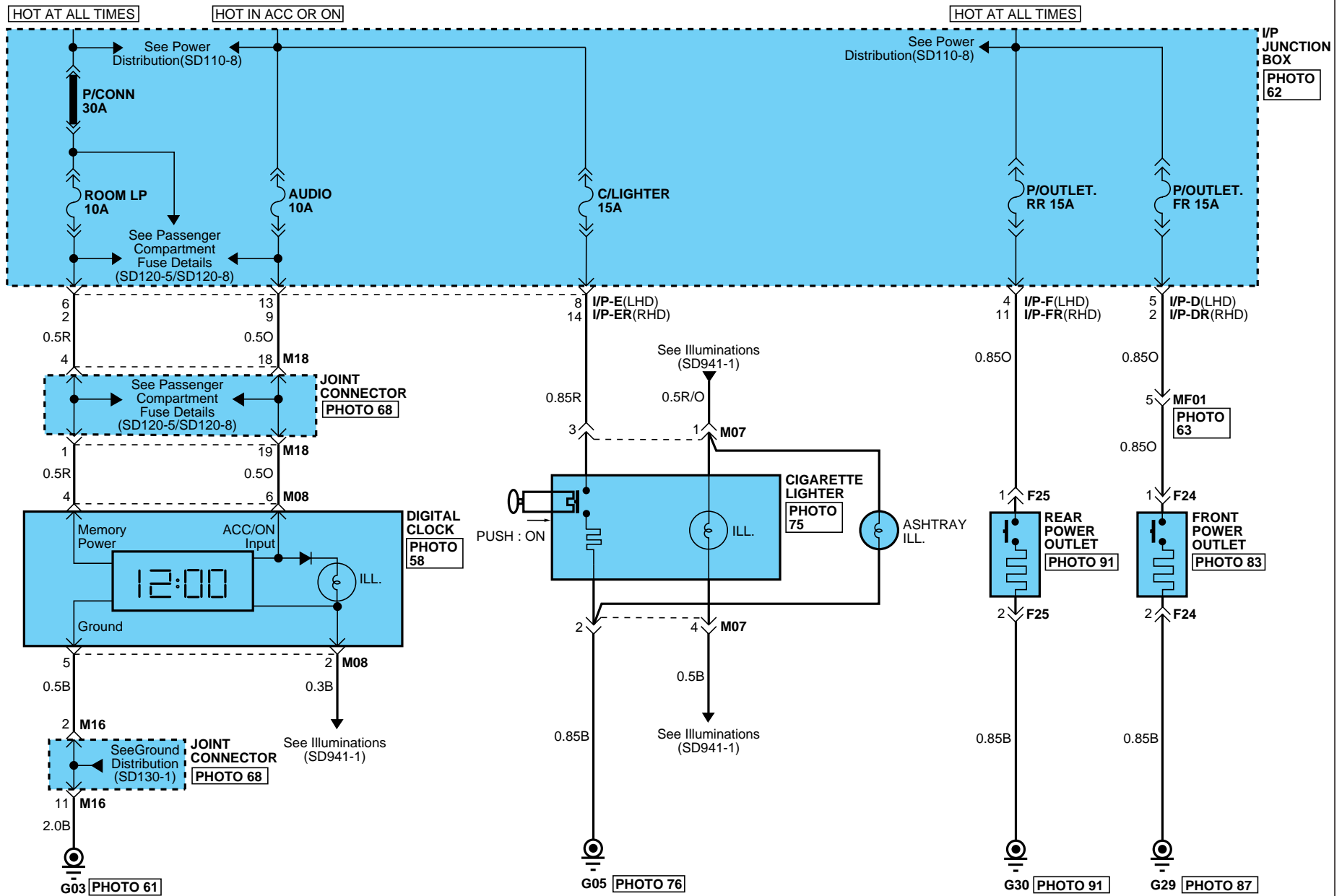

DIGITAL CLOCK & CIGARETTE LIGHTER (POWER OUTLET)

DIGITAL CLOCK & CIGARETTE LIGHTER (POWER OUTLET) (2)

SD945-2

F24

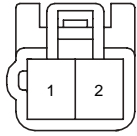

KET_090II_02M_B_R

F25

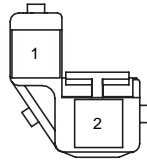

KET_2505_02F_B_CIGAR

M07

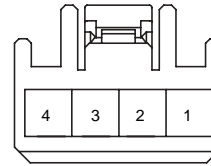

AMP_090III_04F_W

M08

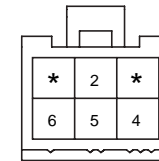

MLX_165_06F_W

AUTO LIGHTS (1)

SD951-1

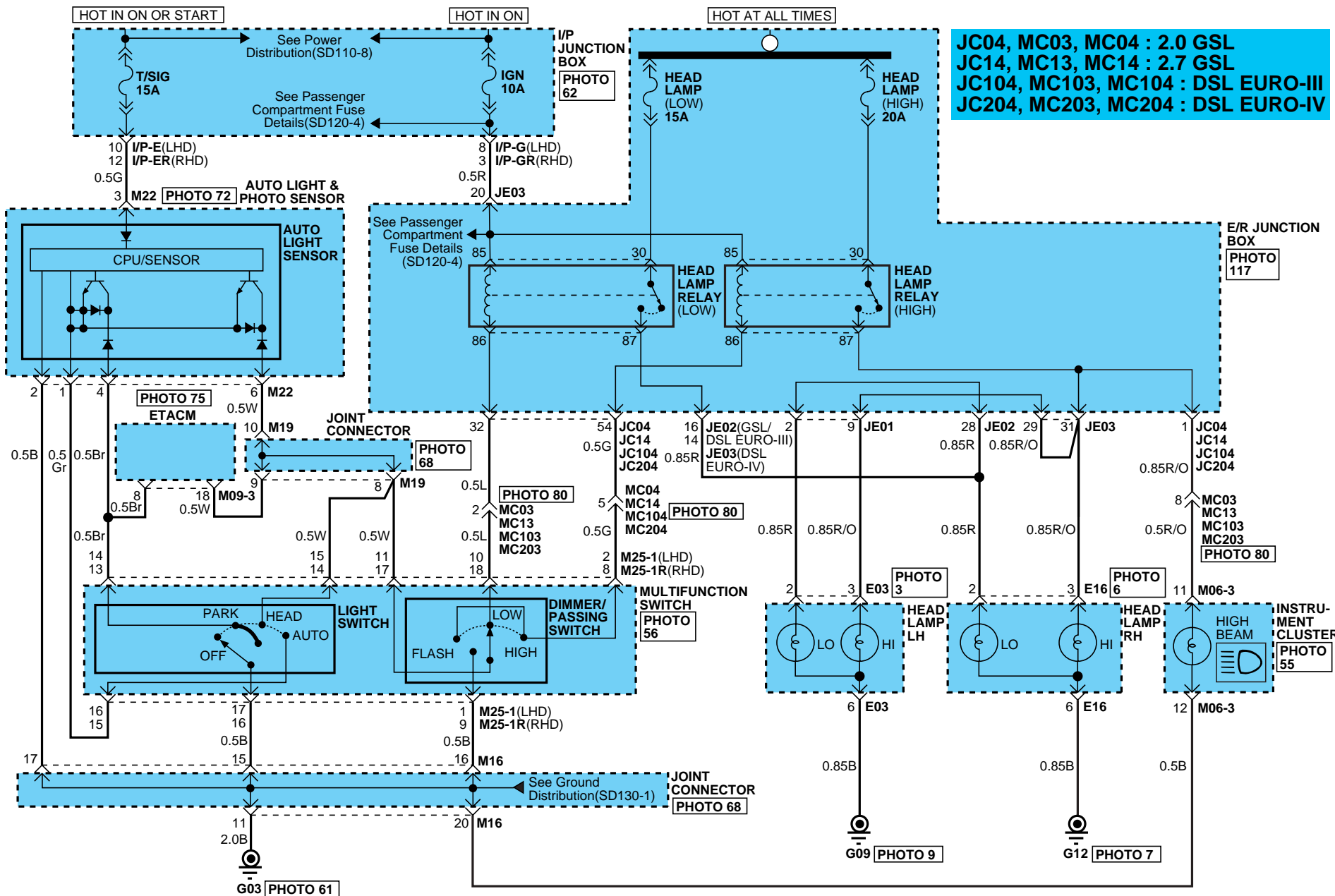

AUTO LIGHTS

AUTO LIGHTS (2)

SD951-2

E03

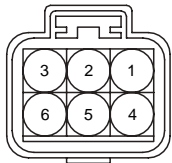

KUM_NMWP_06F_B

E16

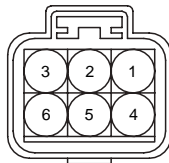

KUM_NMWP_06F_B

M06-3

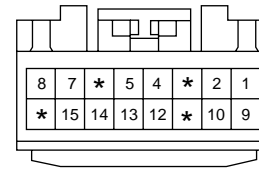

MLX_040III_16F_Gr

M09-3

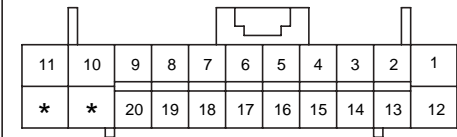

AMP_0407_22F_W_HD

M22

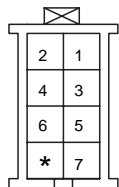

KET_030_08F_GR

M25-1

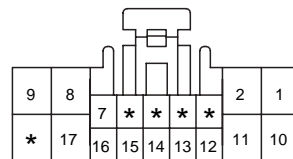

AMP_0509_18F_W

M25-1R

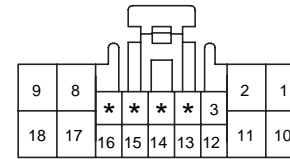

AMP_0509_18F_W

BLANK

ETACS(ELECTRONIC TIME & ALARM CONTROL SYSTEM) (1)

SD952-1

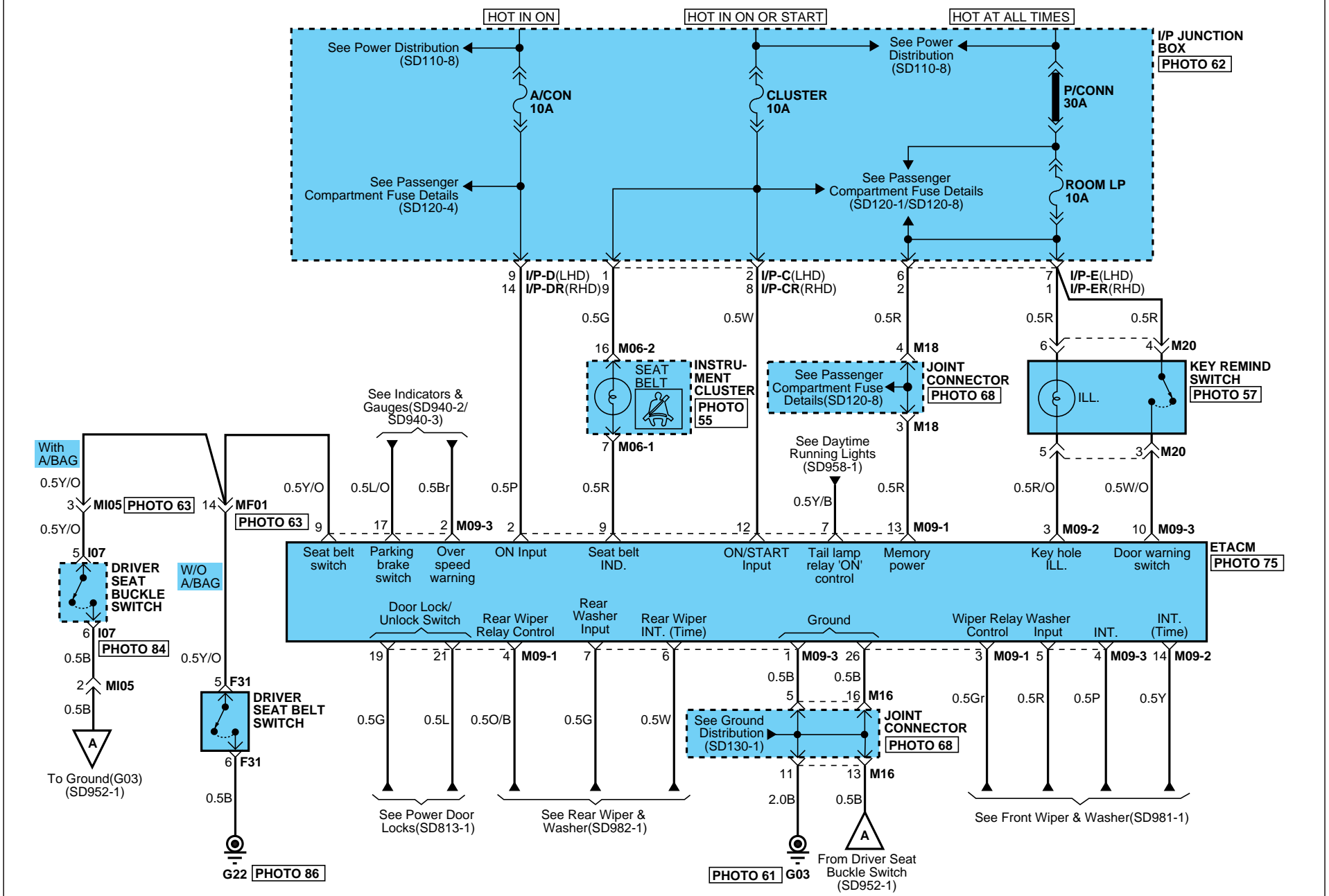

ETACS (ELECTRONIC TIME & ALARM CONTROL SYSTEM)

ETACS(ELECTRONIC TIME & ALARM CONTROL SYSTEM) (2)

SD952-2

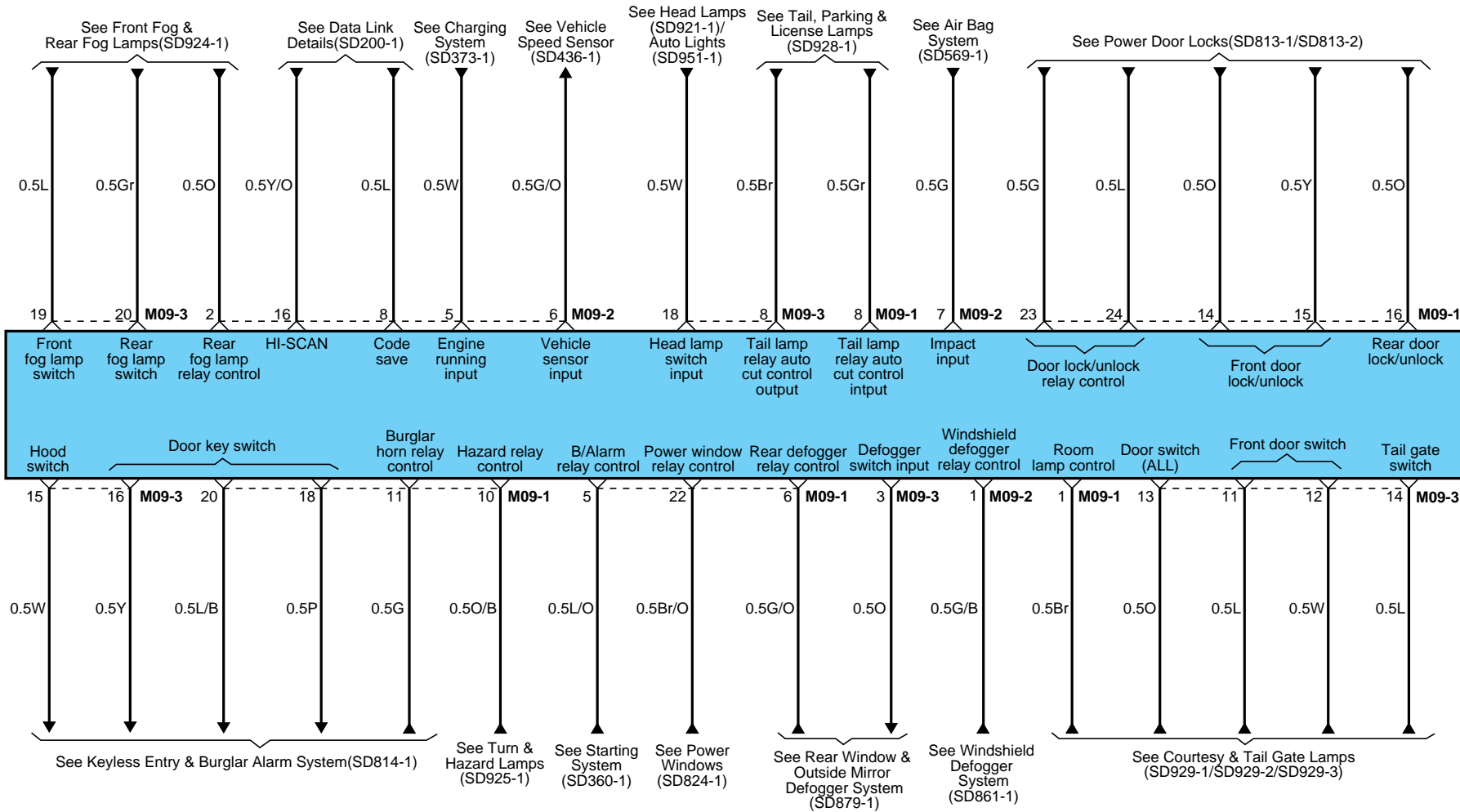

ETACM PHOTO 75

ETACS (ELECTRONIC TIME & ALARM CONTROL SYSTEM)

ETACS(ELECTRONIC TIME & ALARM CONTROL SYSTEM) (3)

SD952-3

I07

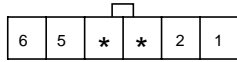

AMP_MQS_6F

F31

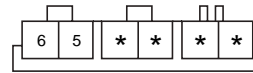

AMP_040_06F

M09-1

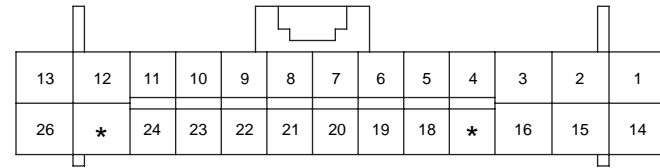

AMP_0407_26F_W_HD

M09-2

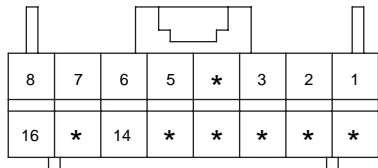

AMP_0407_16F_W_040

M09-3

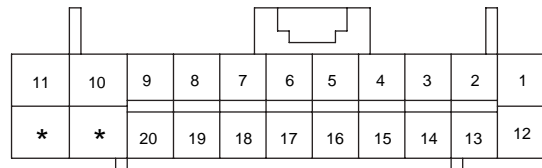

AMP_0407_22F_W_HD

M20

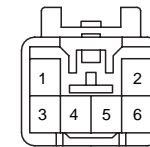

KET_090II_06M_W

ETACS (ELECTRONIC TIME & ALARM CONTROL SYSTEM)

ETACS(ELECTRONIC TIME & ALARM CONTROL SYSTEM) (4)

SD952-4

MEMO

IMMOBILIZER CONTROL SYSTEM (1)

2.0 GASOLINE/DIESEL

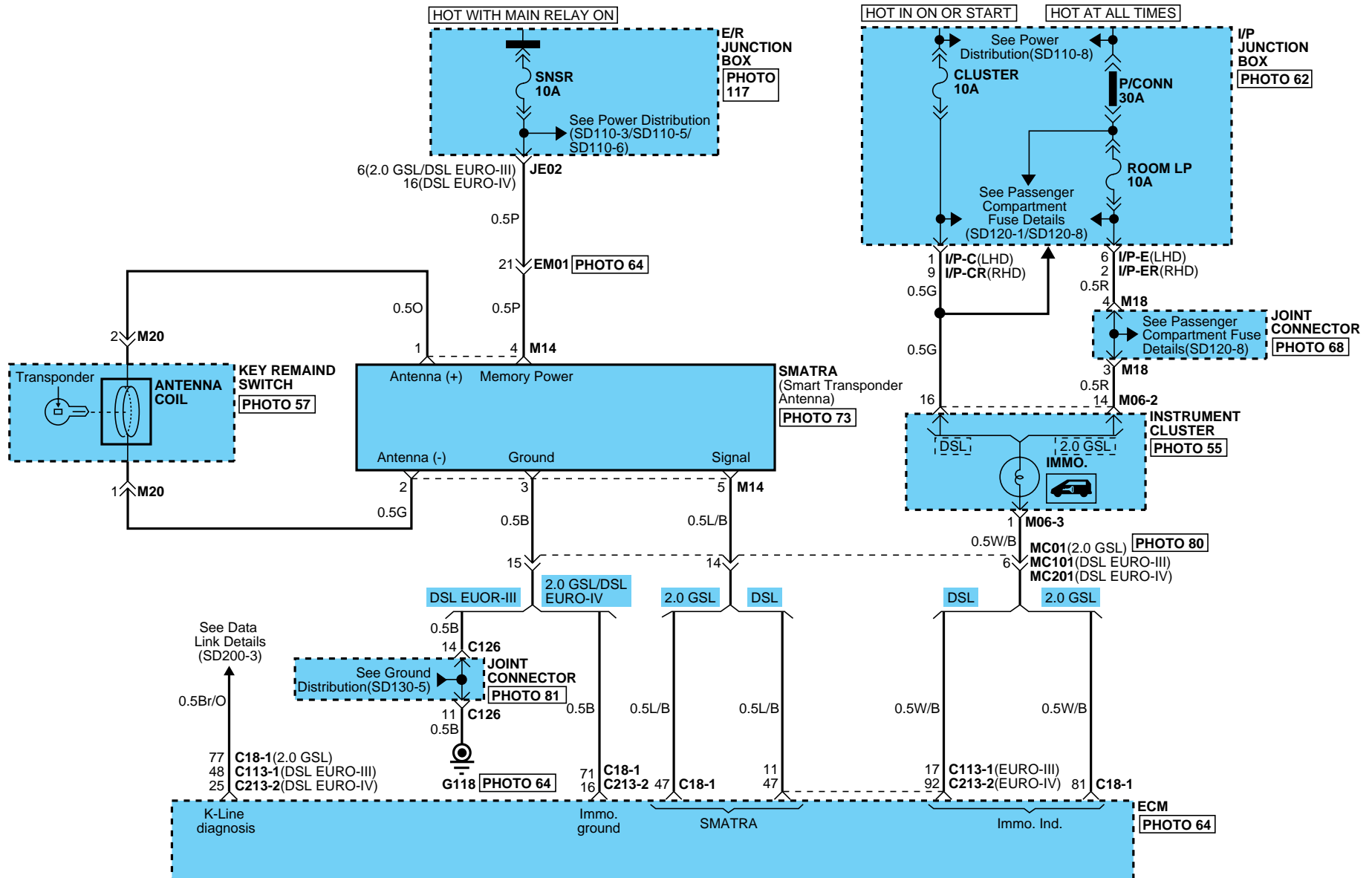

IMMOBILIZER CONTROL SYSTEM

IMMOBILIZER CONTROL SYSTEM (2)

SD954-2

2.7 GASOLINE

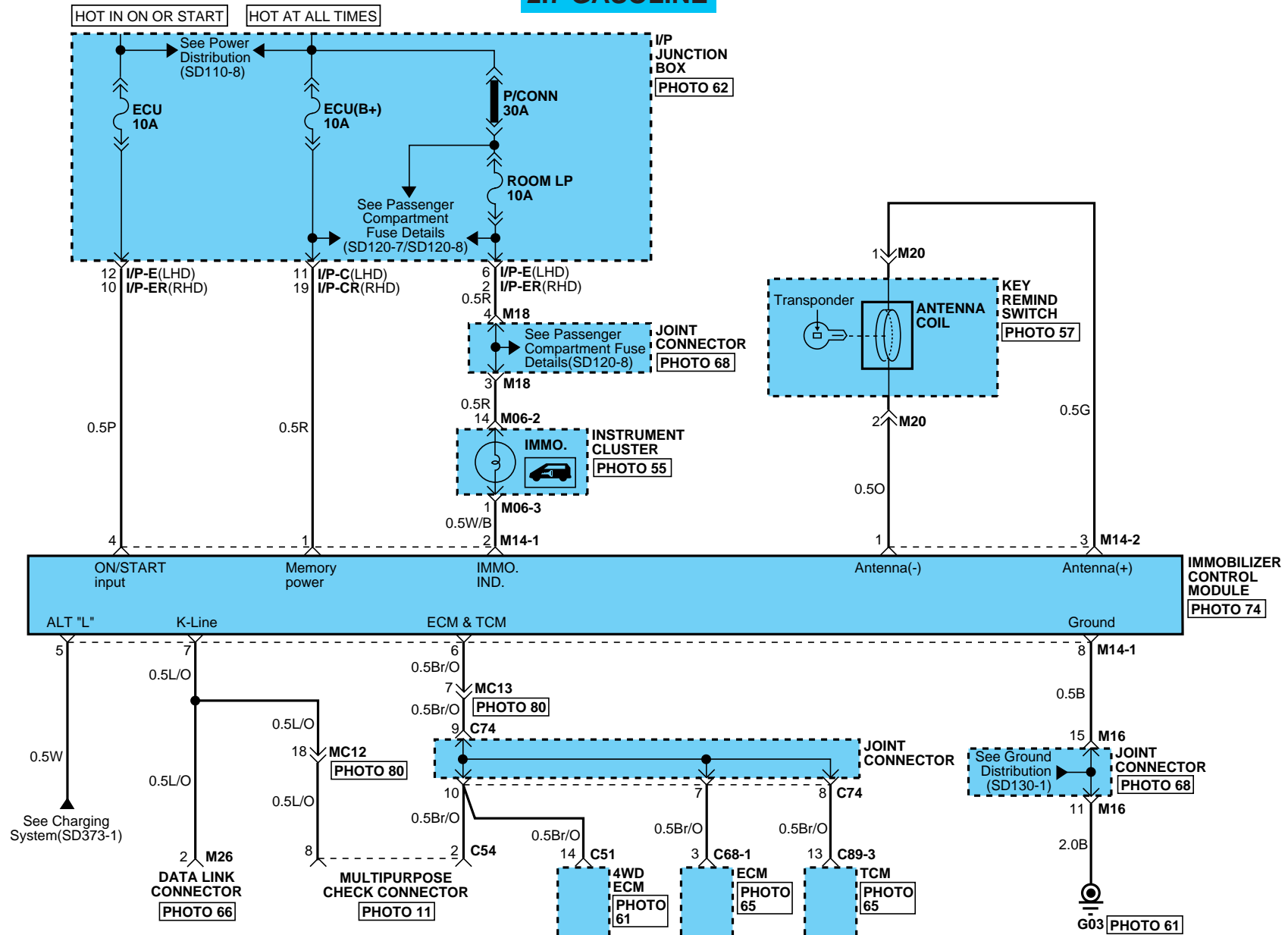

IMMOBILIZER CONTROL SYSTEM

IMMOBILIZER CONTROL SYSTEM (3)

SD954-3

M14

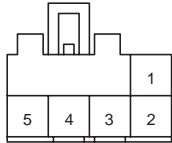

KUM_CDR_05F_W

M14-1

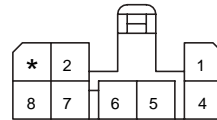

AMP_070_08F_W

M14-2

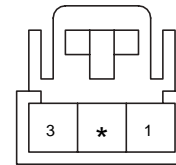

AMP_070_03F_W

M20

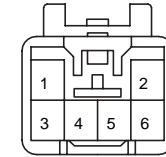

KET_090II_06M_W

C54

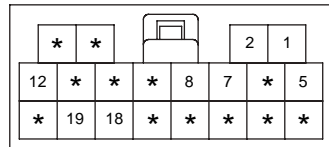

KET_DIAG_20F_B_CLIP

M06-2

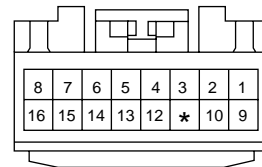

MLX_040III_16F_Gr

M06-3

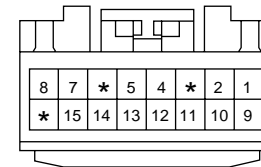

MLX_040III_16F_Gr

BLANK

IMMOBILIZER CONTROL SYSTEM

IMMOBILIZER CONTROL SYSTEM (4)

SD954-4

MEMO

DAYTIME RUNNING LIGHTS (1)

SD958-1

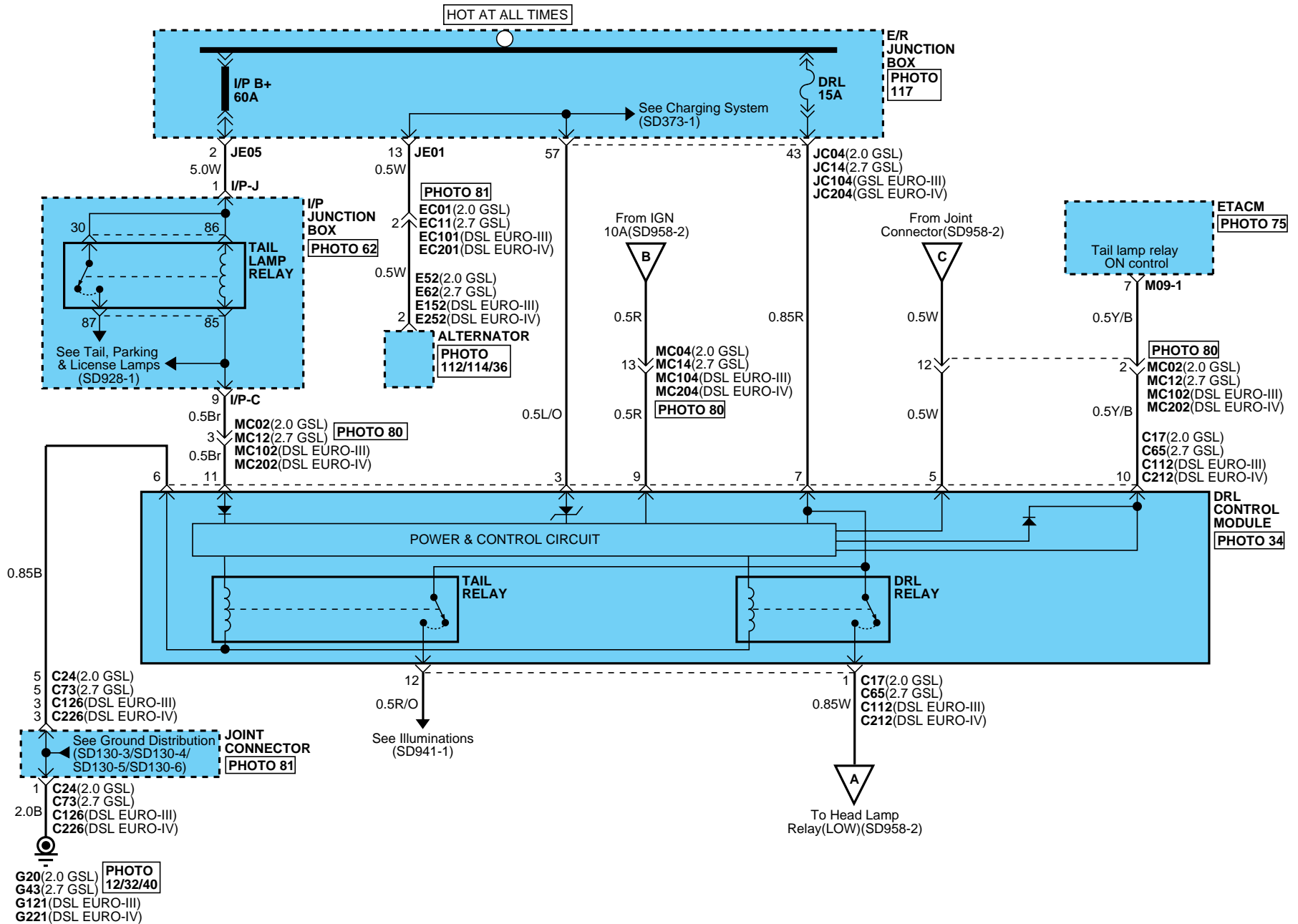

DAYTIME RUNNING LIGHTS

DAYTIME RUNNING LIGHTS (2)

SD958-2

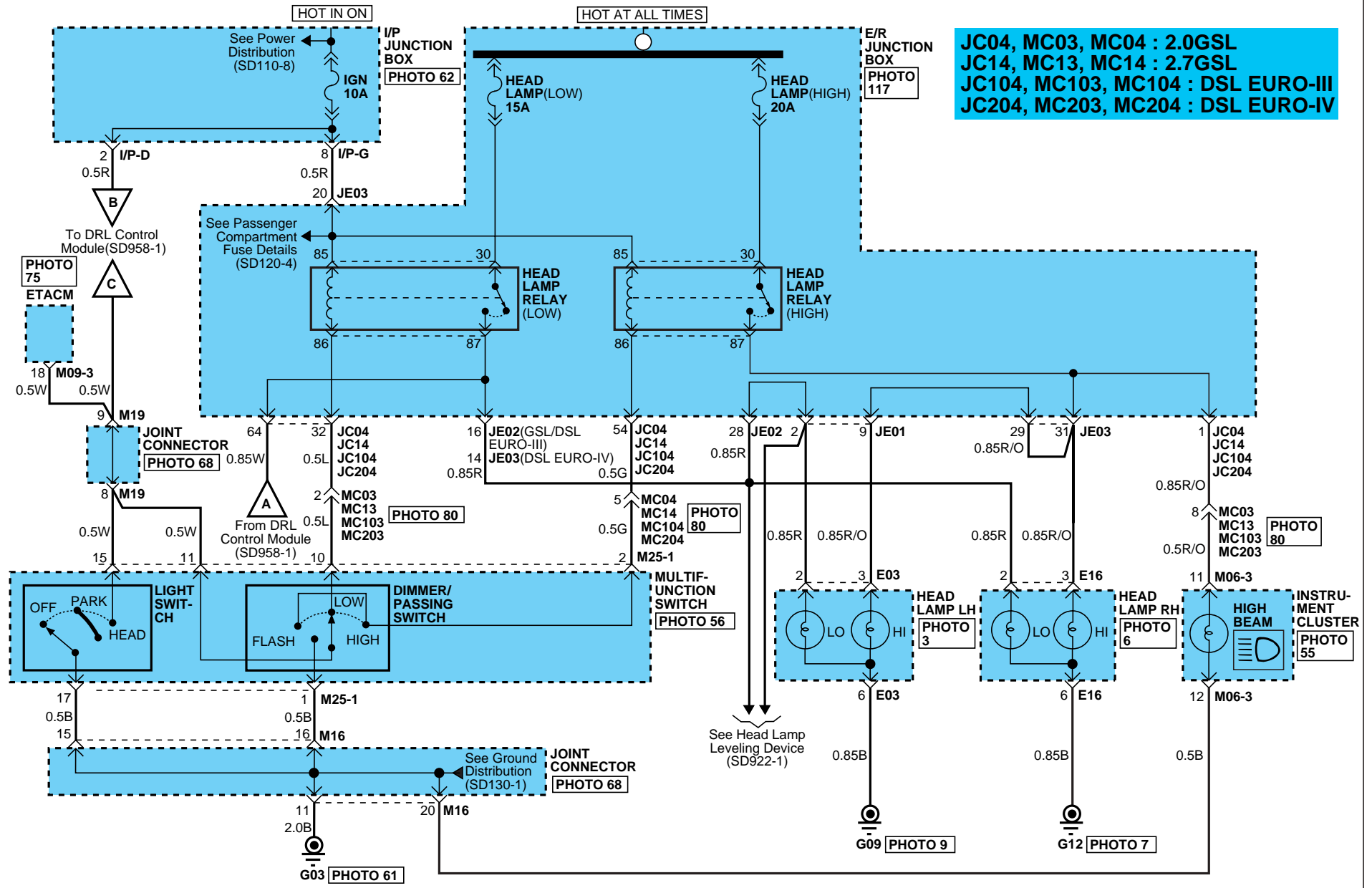

DAYTIME RUNNING LIGHTS

DAYTIME RUNNING LIGHTS (3)

SD958-3

C17/C65/C112/C212

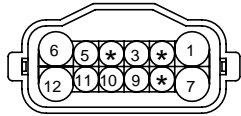

KET_1809WP_12F_Gr

E03

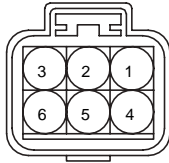

KUM_NMWP_06F_B

E16

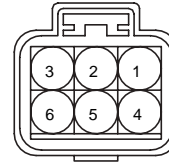

KUM_NMWP_06F_B

E52/E62/E152/E252

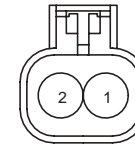

KET_58X_02F_B

M06-3

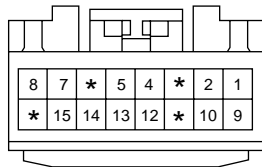

MLX_040III_16F_Gr

M09-3

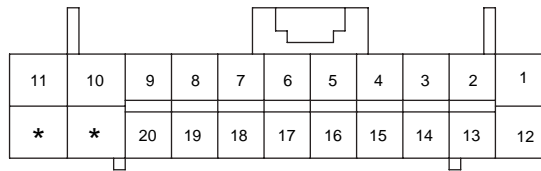

AMP_0407_22F_W_HD

M25-1

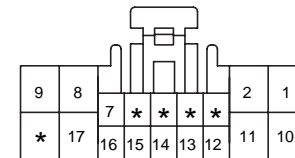

KET_0509_18F_W

DAYTIME RUNNING LIGHTS

DAYTIME RUNNING LIGHTS (4)

SD958-4

MEMO

AUDIO SYSTEM (1)

SD961-1

AMP SPEAKERS

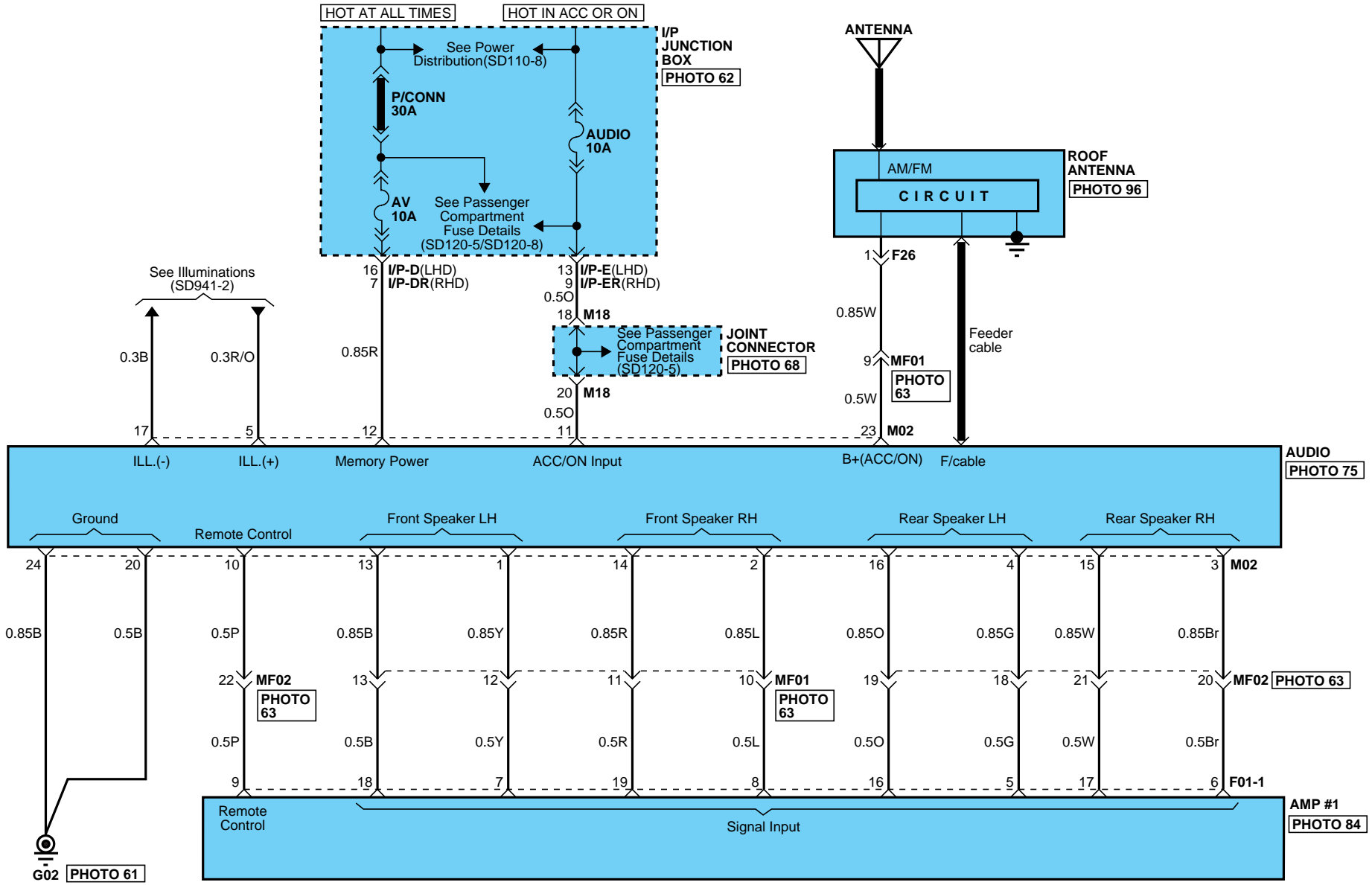

SPEAKERS

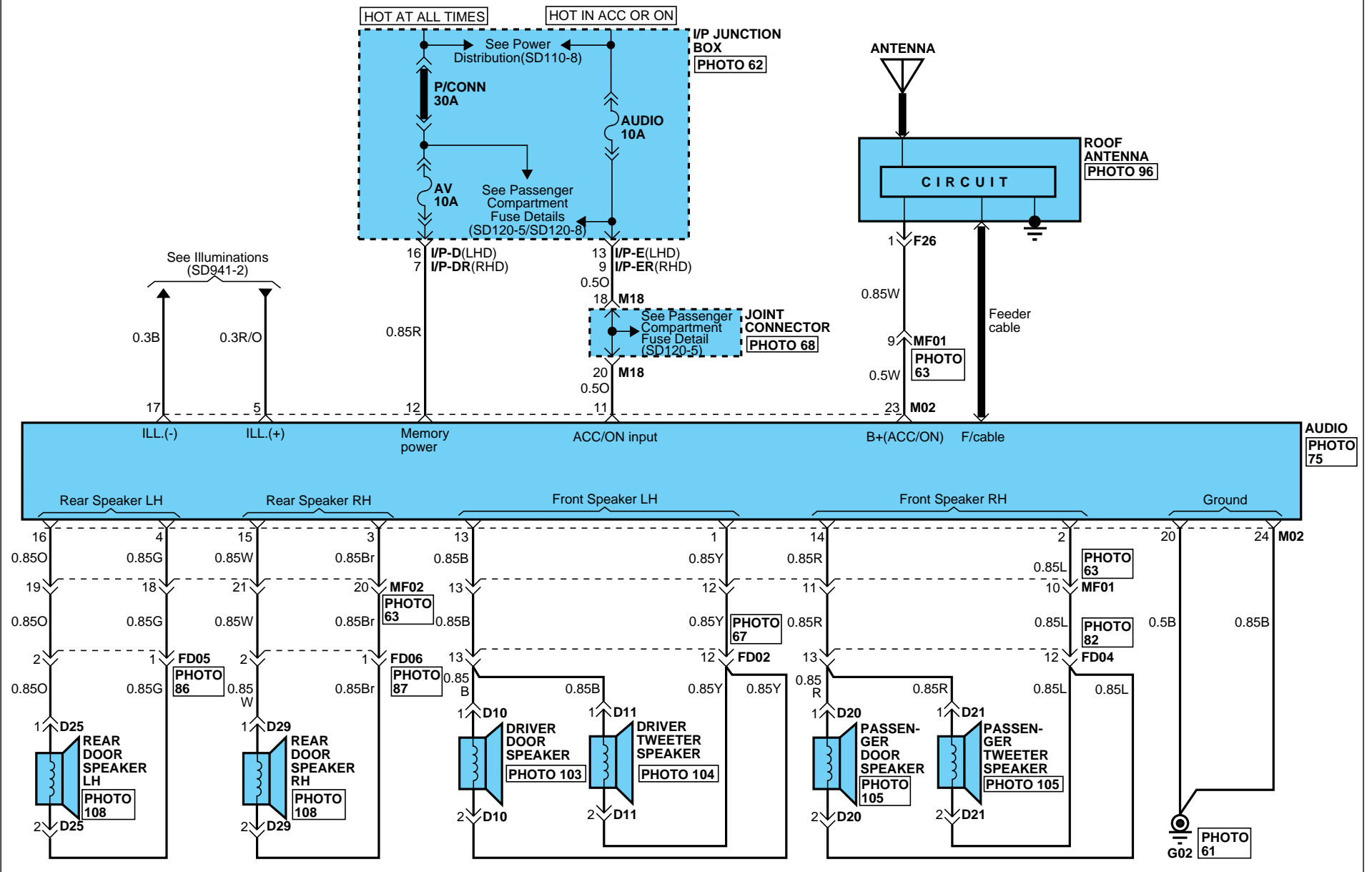

AUDIO SYSTEM

AUDIO SYSTEM (4)

SD961-4

D10

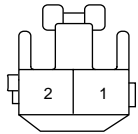

KET_090II_02F_W_L

D11

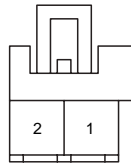

KUM_CDR_02F_B

D20

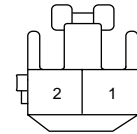

KET_090II_02F_W_L

D21

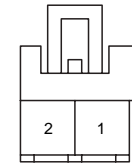

KUM_CDR_02F_B

D25

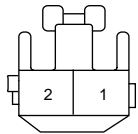

KET_090II_02F_W_L

D29

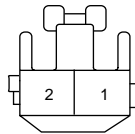

KET_090II_02F_W_L

F01-1

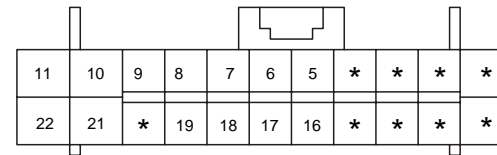

AMP_0407_22F_W_HD

F01-2

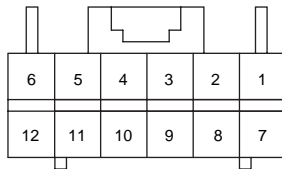

AMP_0407_12F_W_070

F26



AMP_PLM1_01F_B

F30

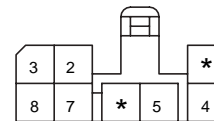

AMP_070_08F_W

M02

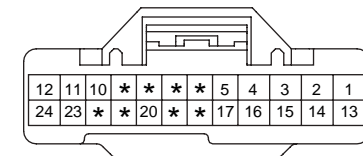

KET_0409_24F_W

CRUISE CONTROL SYSTEM

CRUISE CONTROL SYSTEM (GASOLINE) (2)

SD964-2

C10

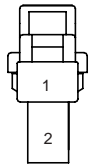

KET_250DL_02F_W

C11/C61

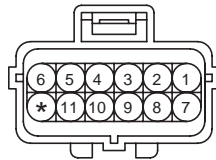

AMP_EJWP_12F_B

C21/C70

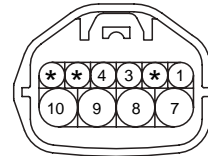

KET_SSD_10F_B_A

C37/C87

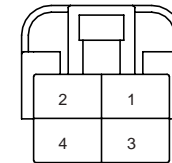

KET_250DL_04F_W

M06-2

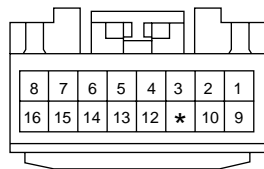

MLX_040III_16F_Gr

M06-3

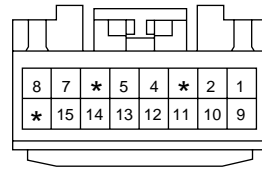

MLX_040III_16F_Gr

M32

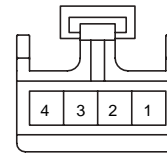

FUR_FA_04F_B_AB

BLANK

HORNS (1)

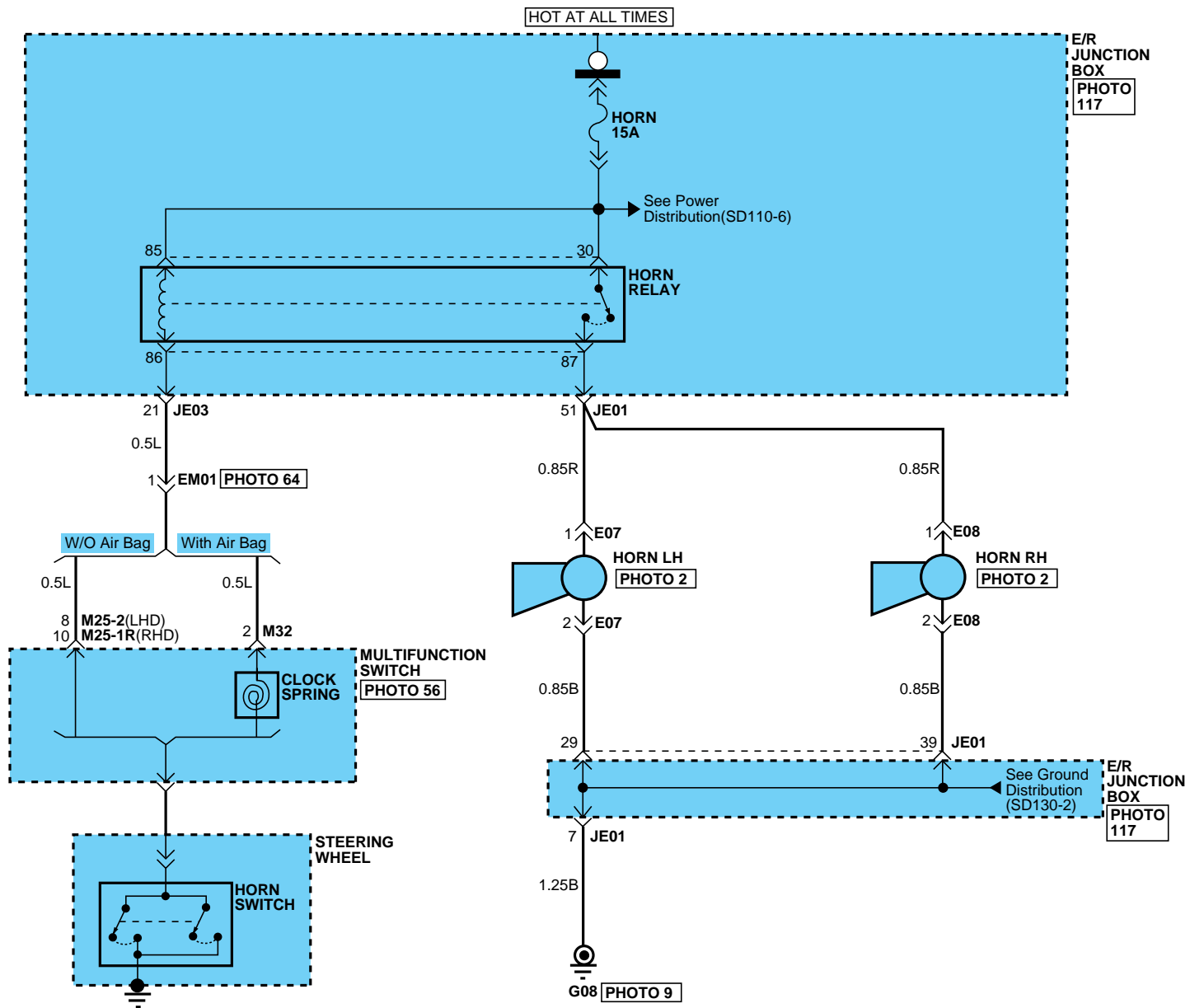

HORNS

HORNS (2)

SD968-2

E07

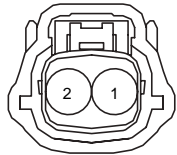

MLX_HORN_02F_B_FILT

E08

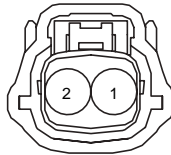

MLX_HORN_02F_B_FILT

M25-1R

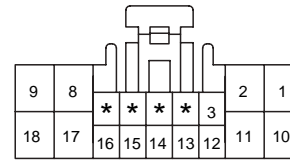

KET_0509_18F_W

M25-2

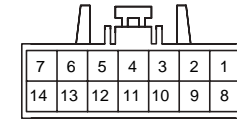

KET_0901L_14F_W_SW

M32

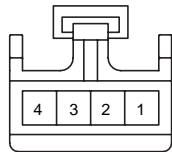

FUR_FA_04F_B_AB

BLANK

BLANK

BLANK

BLOWER & A/C CONTROLS (AUTO) (1)

SD971-1

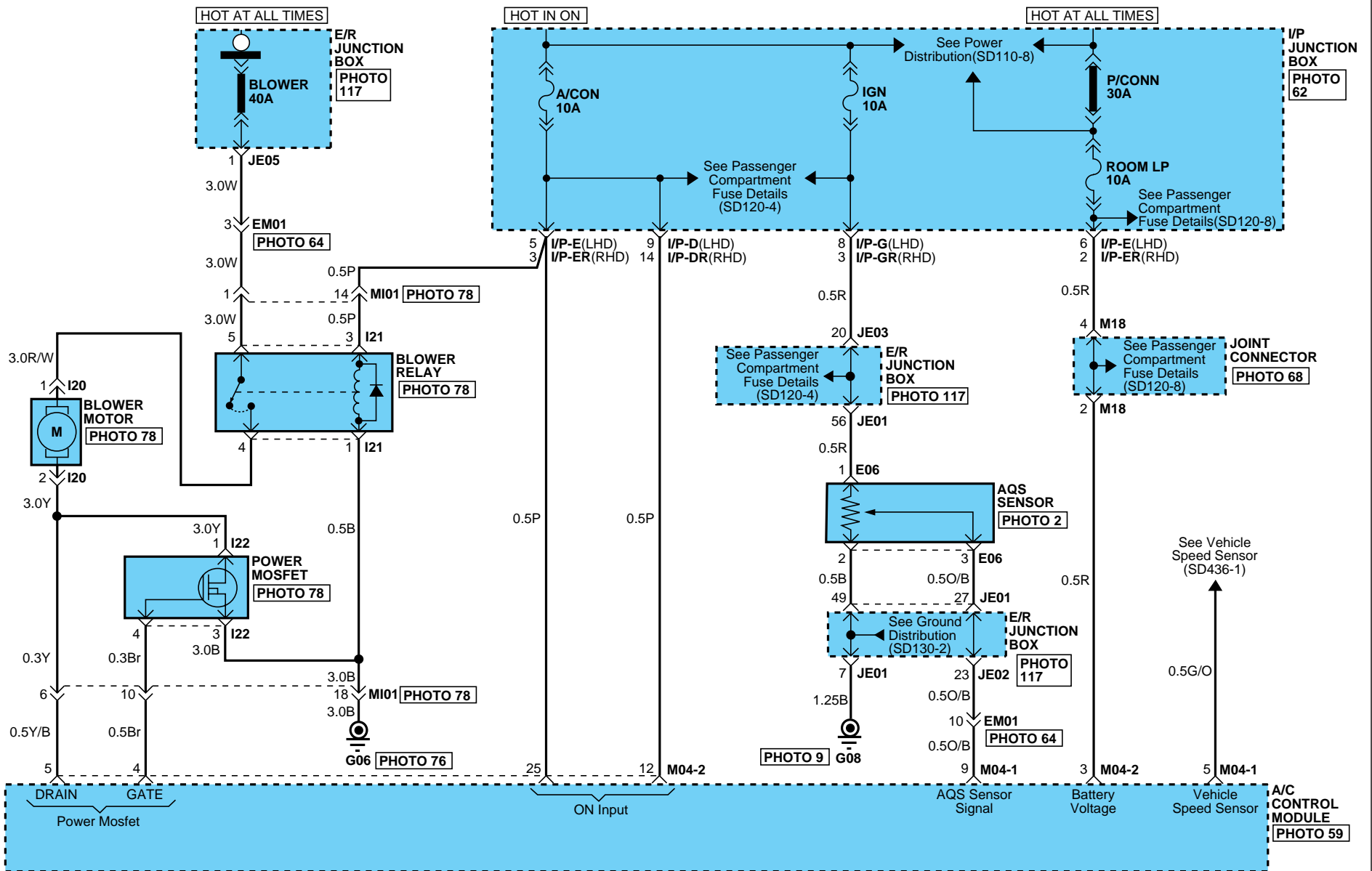

BLOWER & A/C CONTROLS

BLOWER & A/C CONTROLS (AUTO) (2)

SD971-2

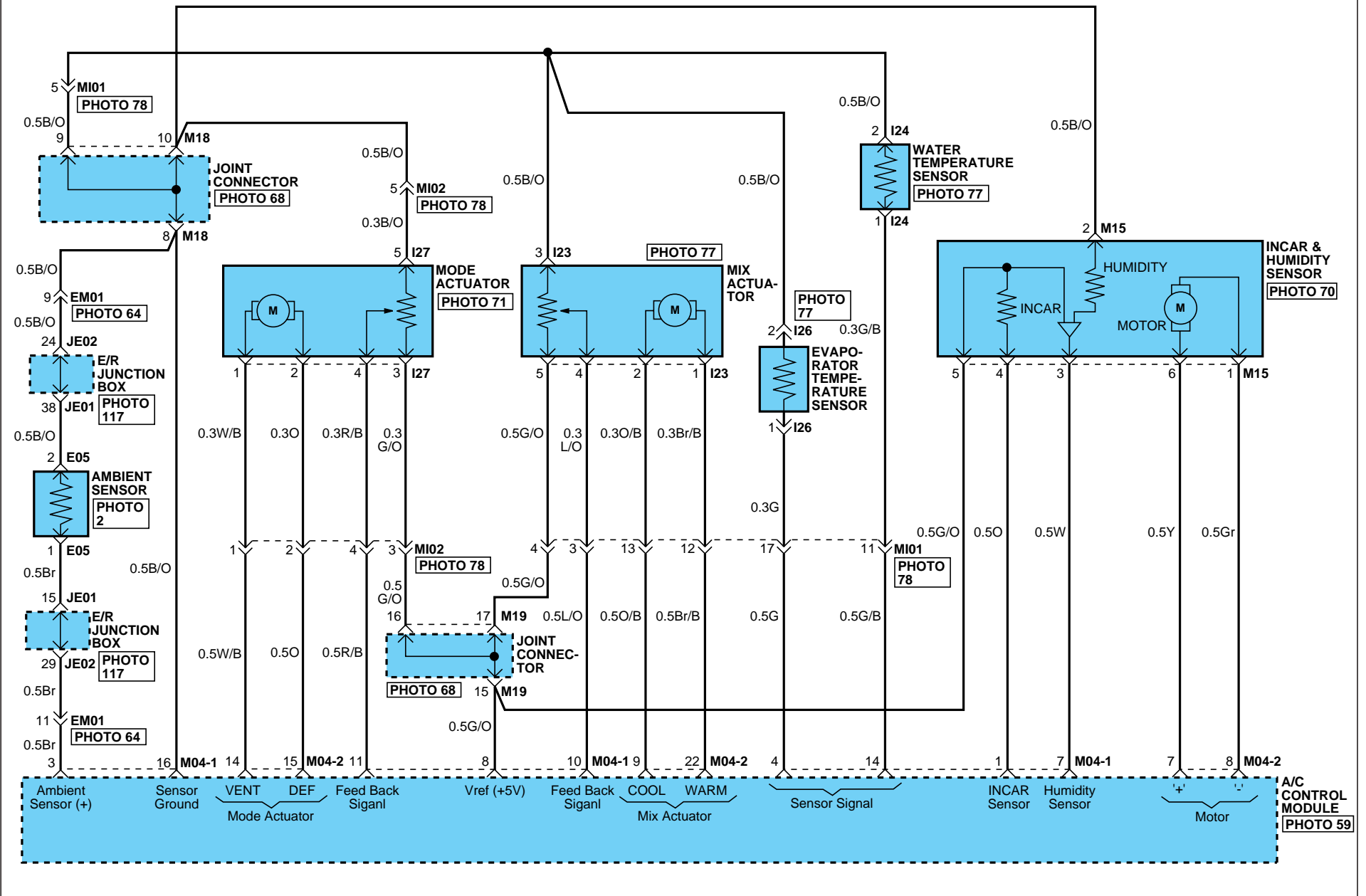

BLOWER & A/C CONTROLS

BLOWER & A/C CONTROLS (AUTO) (3)

SD971-3

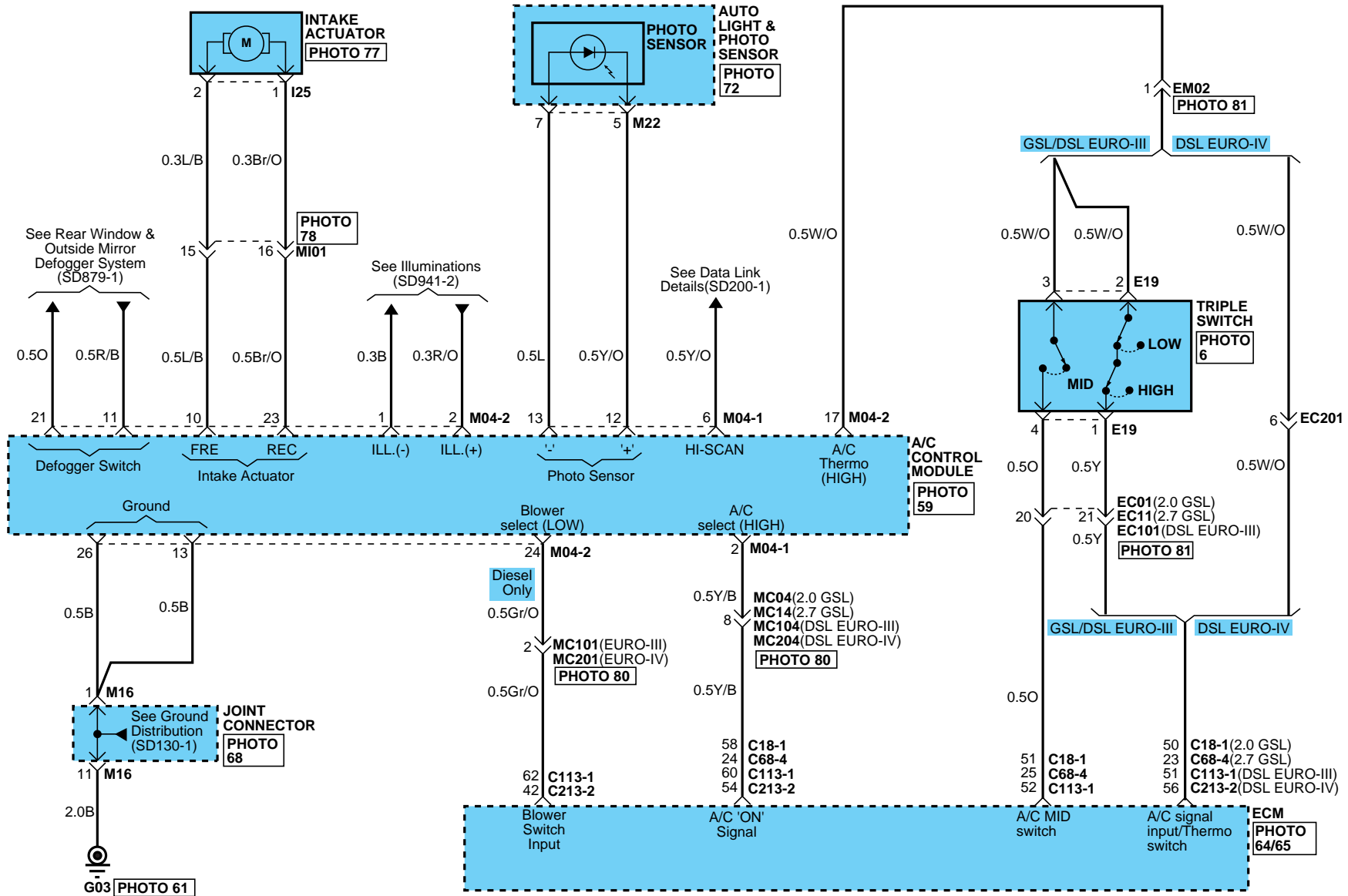

BLOWER & A/C CONTROLS

BLOWER & A/C CONTROLS (AUTO) (4)

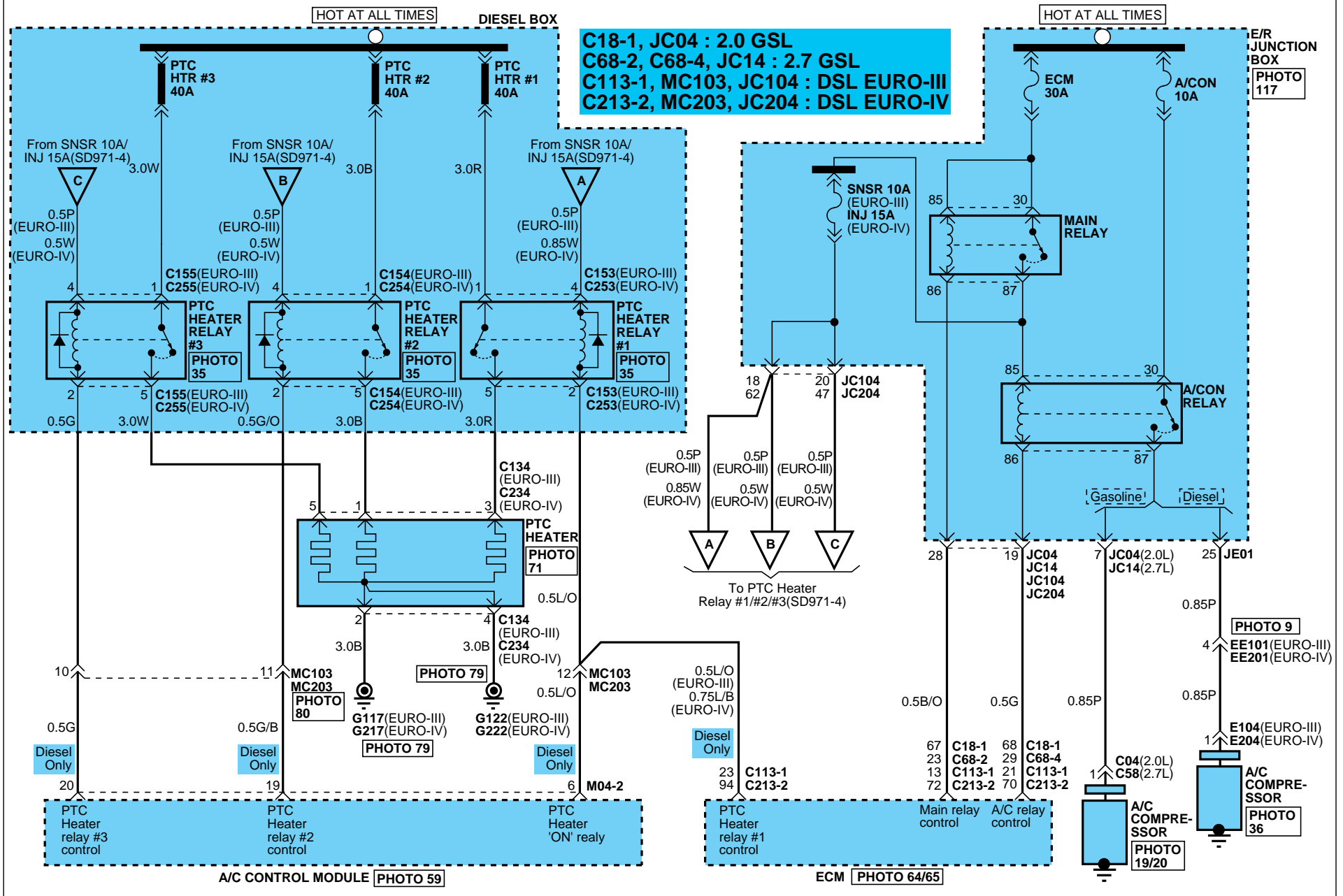

SD971-4



BLOWER & A/C CONTROLS

BLOWER & A/C CONTROLS (AUTO) (5)

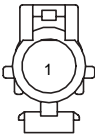
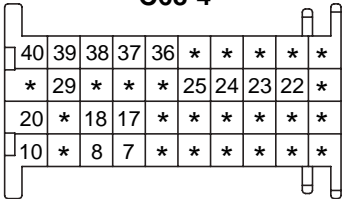
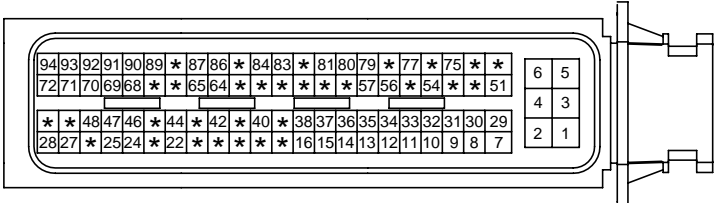
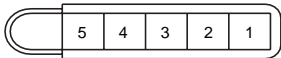
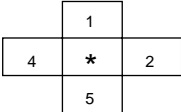
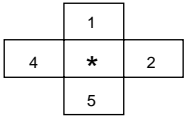
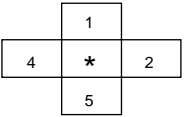
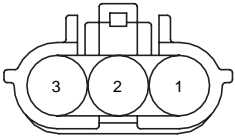
SD971-5

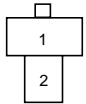
<p>C04</p>  <p>KUM_NMWP_01F_B</p>	<p>C18-1</p> <table border="1" style="width:100%; border-collapse: collapse; text-align: center;"> <tr><td>6</td><td>7</td><td>8</td><td>9</td><td>10</td><td>11</td><td>*</td><td>*</td><td>14</td><td>*</td><td>*</td><td>17</td><td>18</td><td>*</td><td>*</td><td>21</td><td>22</td><td>23</td><td>24</td><td>5</td><td>4</td></tr> <tr><td>*</td><td>26</td><td>27</td><td>*</td><td>29</td><td>30</td><td>31</td><td>32</td><td>*</td><td>*</td><td>*</td><td>*</td><td>37</td><td>38</td><td>39</td><td>*</td><td>*</td><td>42</td><td>43</td><td colspan="2" rowspan="3">3</td></tr> <tr><td>*</td><td>45</td><td>*</td><td>47</td><td>48</td><td>*</td><td>50</td><td>51</td><td>52</td><td>*</td><td>54</td><td>55</td><td>56</td><td>*</td><td>58</td><td>59</td><td>60</td><td>61</td><td>62</td></tr> <tr><td>*</td><td>64</td><td>65</td><td>66</td><td>67</td><td>68</td><td>69</td><td>70</td><td>71</td><td>72</td><td>73</td><td>*</td><td>75</td><td>76</td><td>77</td><td>78</td><td>*</td><td>80</td><td>81</td><td>2</td><td>1</td></tr> </table> <p>KET_ECU_81F</p>	6	7	8	9	10	11	*	*	14	*	*	17	18	*	*	21	22	23	24	5	4	*	26	27	*	29	30	31	32	*	*	*	*	37	38	39	*	*	42	43	3		*	45	*	47	48	*	50	51	52	*	54	55	56	*	58	59	60	61	62	*	64	65	66	67	68	69	70	71	72	73	*	75	76	77	78	*	80	81	2	1	<p>C58</p>  <p>KET_SWP_01F_B</p>																									
6	7	8	9	10	11	*	*	14	*	*	17	18	*	*	21	22	23	24	5	4																																																																																									
*	26	27	*	29	30	31	32	*	*	*	*	37	38	39	*	*	42	43	3																																																																																										
*	45	*	47	48	*	50	51	52	*	54	55	56	*	58	59	60	61	62																																																																																											
*	64	65	66	67	68	69	70	71	72	73	*	75	76	77	78	*	80	81			2	1																																																																																							
<p>C68-2</p> <table border="1" style="width:100%; border-collapse: collapse; text-align: center;"> <tr><td>24</td><td>23</td><td>22</td><td>21</td><td>20</td><td>19</td></tr> <tr><td>18</td><td>17</td><td>16</td><td>15</td><td>14</td><td>13</td></tr> <tr><td>*</td><td>*</td><td>*</td><td>*</td><td>*</td><td>7</td></tr> <tr><td>*</td><td>*</td><td>*</td><td>*</td><td>*</td><td>1</td></tr> </table> <p>AMP_ECU_24F_B_134P</p>	24	23	22	21	20	19	18	17	16	15	14	13	*	*	*	*	*	7	*	*	*	*	*	1	<p>C68-4</p>  <p>AMP_ECU_40F_B_134P</p>	<p>C113-1</p> <table border="1" style="width:100%; border-collapse: collapse; text-align: center;"> <tr><td>*</td><td>*</td><td>*</td><td>9</td><td>10</td><td>11</td><td>12</td><td>13</td><td>14</td><td>15</td><td>16</td><td>17</td><td>18</td><td>19</td><td>20</td><td>21</td><td>*</td><td>23</td><td>24</td><td>5</td><td>4</td></tr> <tr><td>*</td><td>*</td><td>*</td><td>*</td><td>*</td><td>*</td><td>*</td><td>*</td><td>*</td><td>*</td><td>*</td><td>*</td><td>*</td><td>*</td><td>*</td><td>40</td><td>*</td><td>*</td><td>*</td><td colspan="2" rowspan="3">3</td></tr> <tr><td>*</td><td>*</td><td>*</td><td>47</td><td>48</td><td>49</td><td>*</td><td>51</td><td>52</td><td>53</td><td>54</td><td>*</td><td>56</td><td>*</td><td>58</td><td>59</td><td>60</td><td>61</td><td>62</td></tr> <tr><td>*</td><td>*</td><td>*</td><td>*</td><td>*</td><td>*</td><td>*</td><td>*</td><td>*</td><td>*</td><td>*</td><td>74</td><td>75</td><td>76</td><td>77</td><td>78</td><td>79</td><td>80</td><td>81</td><td>2</td><td>1</td></tr> </table> <p>KET_ECU_81F</p>		*	*	*	9	10	11	12	13	14	15	16	17	18	19	20	21	*	23	24	5	4	*	*	*	*	*	*	*	*	*	*	*	*	*	*	*	40	*	*	*	3		*	*	*	47	48	49	*	51	52	53	54	*	56	*	58	59	60	61	62	*	*	*	*	*	*	*	*	*	*	*	74	75	76	77	78	79	80	81	2	1
24	23	22	21	20	19																																																																																																								
18	17	16	15	14	13																																																																																																								
*	*	*	*	*	7																																																																																																								
*	*	*	*	*	1																																																																																																								
*	*	*	9	10	11	12	13	14	15	16	17	18	19	20	21	*	23	24	5	4																																																																																									
*	*	*	*	*	*	*	*	*	*	*	*	*	*	*	40	*	*	*	3																																																																																										
*	*	*	47	48	49	*	51	52	53	54	*	56	*	58	59	60	61	62																																																																																											
*	*	*	*	*	*	*	*	*	*	*	74	75	76	77	78	79	80	81			2	1																																																																																							
<p>C213-2</p>  <p>AMP_ECU_94F_B</p>		<p>C134/C234</p>  <p>PRONER_980103_89129</p>	<p>C153/C253</p> 																																																																																																										
<p>C154/C254</p> 	<p>C155/C255</p> 	<p>BLANK</p>																																																																																																											
<p>E06</p>  <p>KET_SWP_03F_B</p>	<p>E19</p>  <p>AMP_EJMP_04F_B</p>	<p>E104/E204</p>  <p>KUM_NMWP_01F_B</p>	<p>I20</p>  <p>KUM_PH776_02025</p>																																																																																																										

BLOWER & A/C CONTROLS

BLOWER & A/C CONTROLS (AUTO) (6)

SD971-6

I21

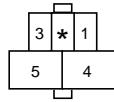

KET_MG612109

I22

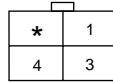

KUM_PH776_04027

I23

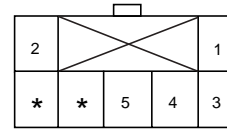

KUM_PH845_07020

I25

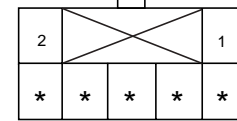

KUM_PH845_07020

I26

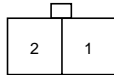

AMP_174463_1

I27

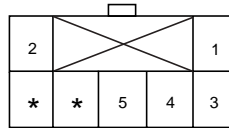

KUM_PH845_07020

M04-2

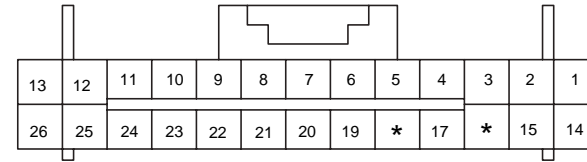

AMP_0407_26F_W_HD

M04-1

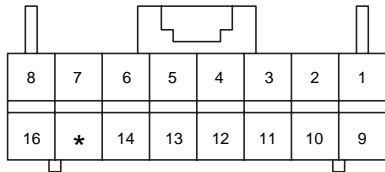

AMP_0407_16F_W_040

M15

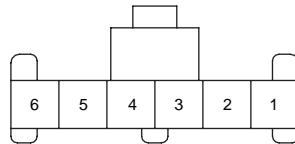

KET_91A_06F_W

M22

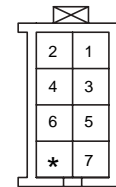

KET_030_08F_GR

BLANK

BLOWER & A/C CONTROLS (MANUAL) (1)

SD971-7

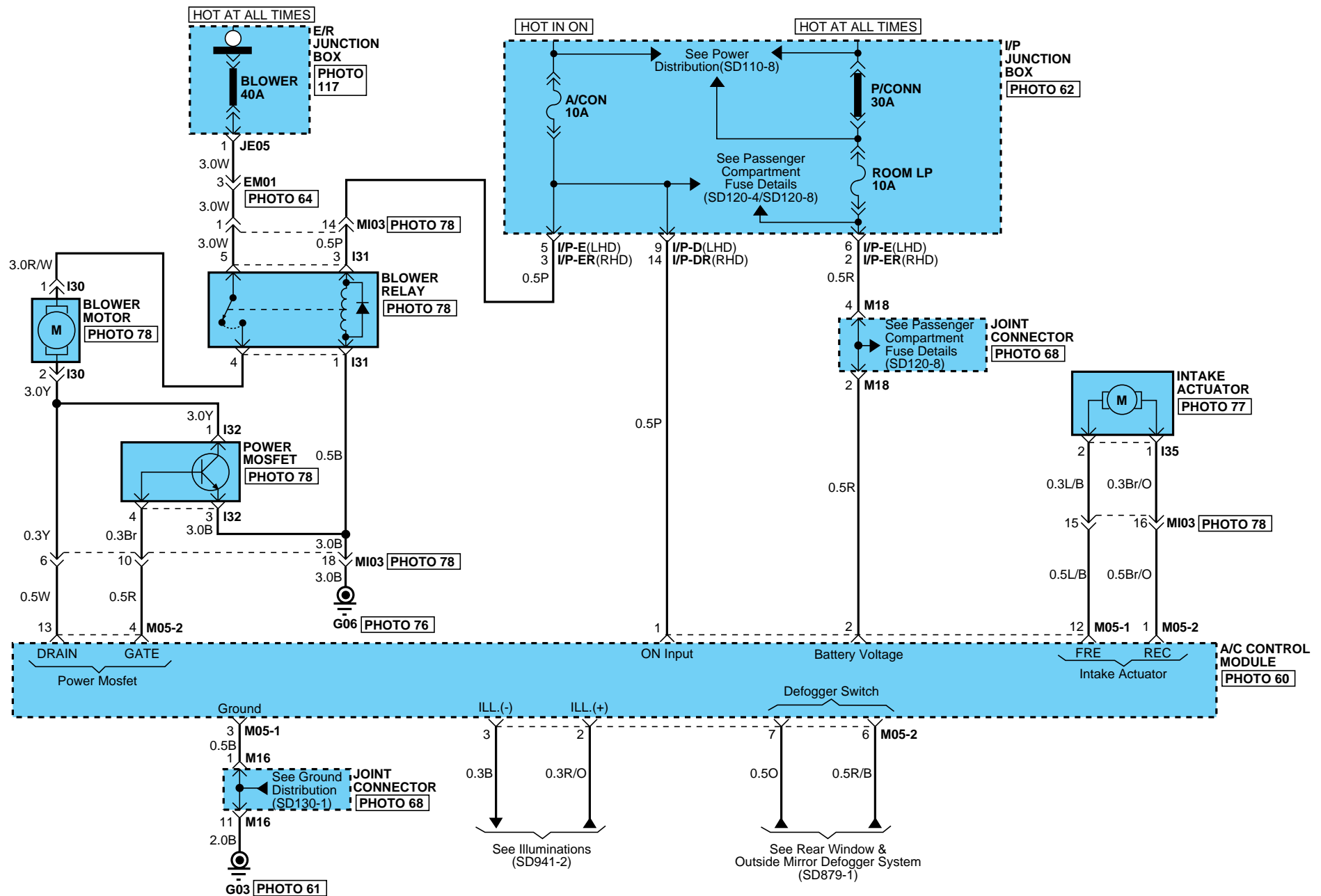

BLOWER & A/C CONTROLS

BLOWER & A/C CONTROLS (MANUAL) (2)

SD971-8

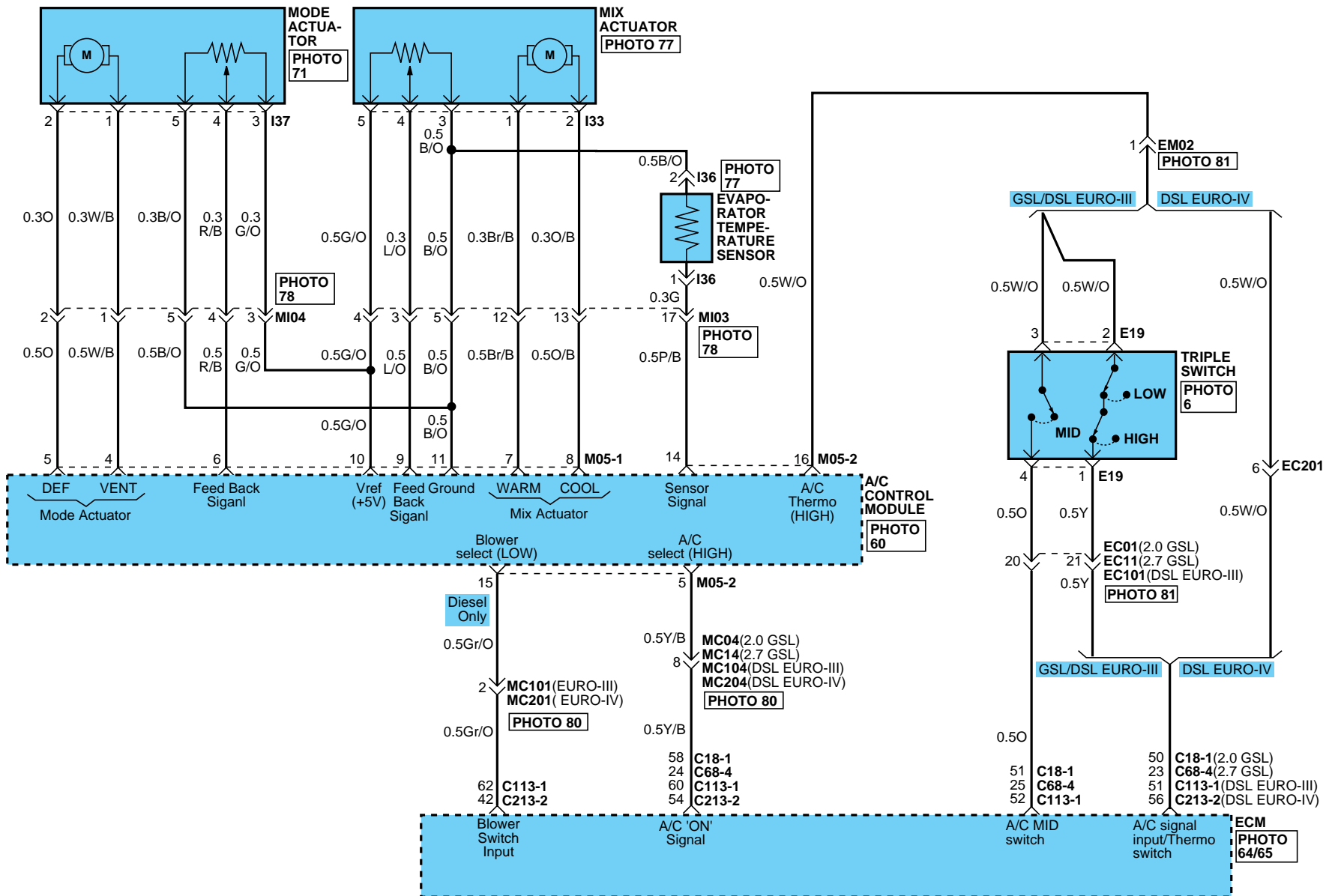

BLOWER & A/C CONTROLS

BLOWER & A/C CONTROLS (MANUAL) (3)

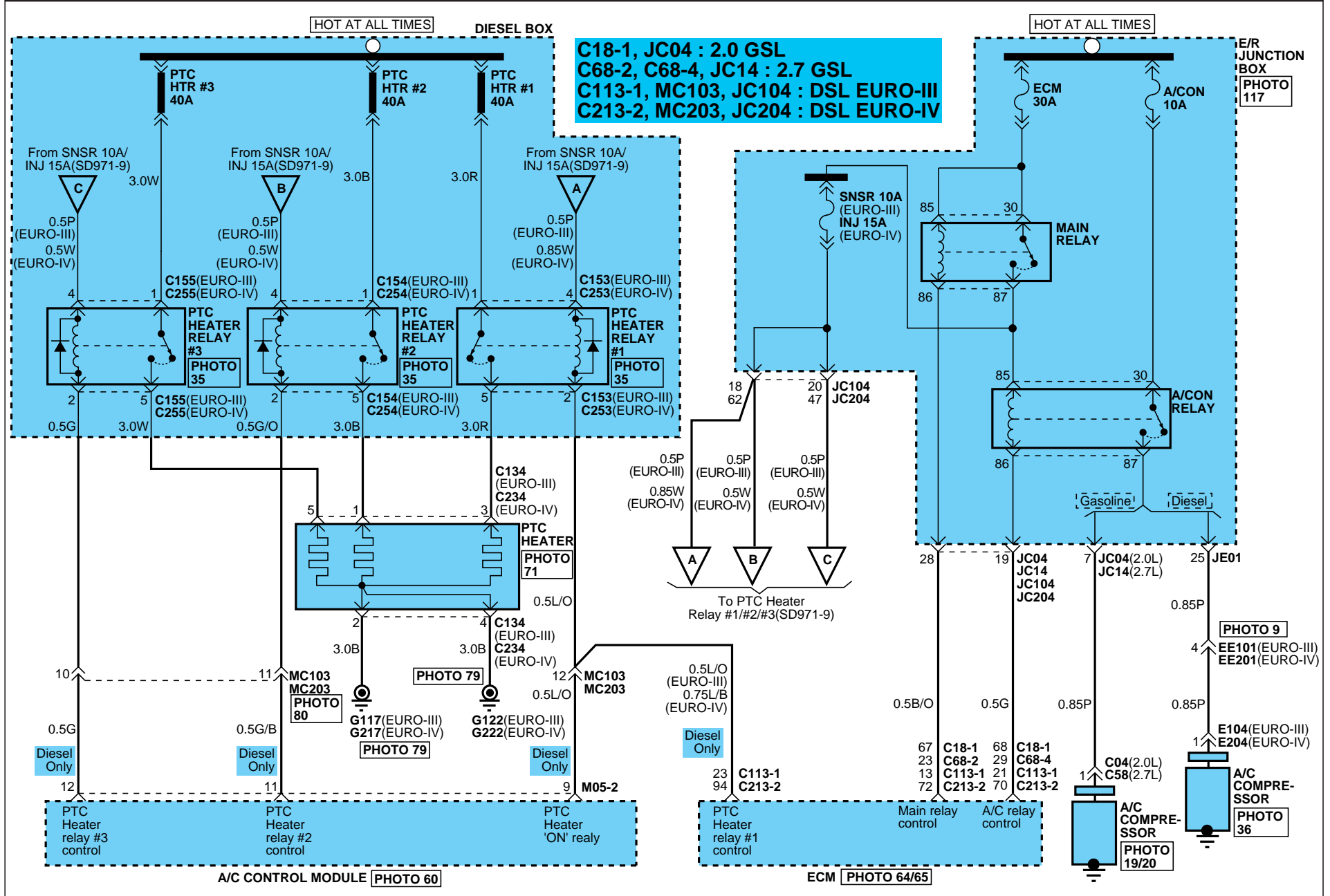

SD971-9



BLOWER & A/C CONTROLS

BLOWER & A/C CONTROLS (MANUAL) (4)

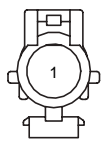
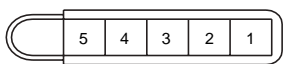
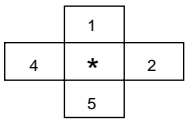
SD971-10

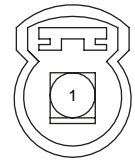
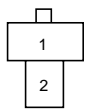
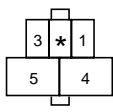
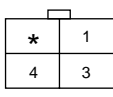
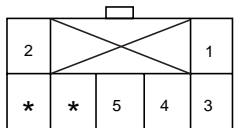
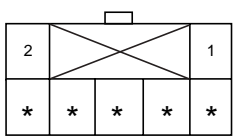
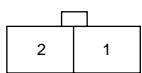
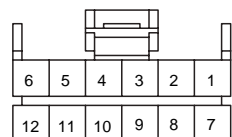
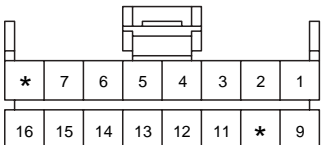
<p>C04</p>  <p style="text-align: center;">KUM_NMWP_01F_B</p>	<p>C18-1</p> <table border="1" style="width:100%; border-collapse: collapse; text-align: center;"> <tr><td>6</td><td>7</td><td>8</td><td>9</td><td>10</td><td>11</td><td>*</td><td>*</td><td>14</td><td>*</td><td>*</td><td>17</td><td>18</td><td>*</td><td>*</td><td>21</td><td>22</td><td>23</td><td>24</td><td>5</td><td>4</td></tr> <tr><td>*</td><td>26</td><td>27</td><td>*</td><td>29</td><td>30</td><td>31</td><td>32</td><td>*</td><td>*</td><td>*</td><td>*</td><td>37</td><td>38</td><td>39</td><td>*</td><td>*</td><td>42</td><td>43</td><td colspan="2" rowspan="3" style="text-align: center; vertical-align: middle;">3</td></tr> <tr><td>*</td><td>45</td><td>*</td><td>47</td><td>48</td><td>*</td><td>50</td><td>51</td><td>52</td><td>*</td><td>54</td><td>55</td><td>56</td><td>*</td><td>58</td><td>59</td><td>60</td><td>61</td><td>62</td></tr> <tr><td>*</td><td>64</td><td>65</td><td>66</td><td>67</td><td>68</td><td>69</td><td>70</td><td>71</td><td>72</td><td>73</td><td>*</td><td>75</td><td>76</td><td>77</td><td>78</td><td>*</td><td>80</td><td>81</td><td>2</td><td>1</td></tr> </table> <p style="text-align: right;">KET_ECU_81F</p>	6	7	8	9	10	11	*	*	14	*	*	17	18	*	*	21	22	23	24	5	4	*	26	27	*	29	30	31	32	*	*	*	*	37	38	39	*	*	42	43	3		*	45	*	47	48	*	50	51	52	*	54	55	56	*	58	59	60	61	62	*	64	65	66	67	68	69	70	71	72	73	*	75	76	77	78	*	80	81	2	1	<p>C58</p>  <p style="text-align: center;">KET_SWP_01F_B</p>																																																																
6	7	8	9	10	11	*	*	14	*	*	17	18	*	*	21	22	23	24	5	4																																																																																																																																
*	26	27	*	29	30	31	32	*	*	*	*	37	38	39	*	*	42	43	3																																																																																																																																	
*	45	*	47	48	*	50	51	52	*	54	55	56	*	58	59	60	61	62																																																																																																																																		
*	64	65	66	67	68	69	70	71	72	73	*	75	76	77	78	*	80	81			2	1																																																																																																																														
<p>C68-2</p> <table border="1" style="width:100%; border-collapse: collapse; text-align: center;"> <tr><td>24</td><td>23</td><td>22</td><td>21</td><td>20</td><td>19</td></tr> <tr><td>18</td><td>17</td><td>16</td><td>15</td><td>14</td><td>13</td></tr> <tr><td>*</td><td>*</td><td>*</td><td>*</td><td>*</td><td>7</td></tr> <tr><td>*</td><td>*</td><td>*</td><td>*</td><td>*</td><td>1</td></tr> </table> <p style="text-align: center;">AMP_ECU_24F_B_134P</p>	24	23	22	21	20	19	18	17	16	15	14	13	*	*	*	*	*	7	*	*	*	*	*	1	<p>C68-4</p> <table border="1" style="width:100%; border-collapse: collapse; text-align: center;"> <tr><td>40</td><td>39</td><td>38</td><td>37</td><td>36</td><td>*</td><td>*</td><td>*</td><td>*</td><td>*</td></tr> <tr><td>*</td><td>29</td><td>*</td><td>*</td><td>*</td><td>25</td><td>24</td><td>23</td><td>22</td><td>*</td></tr> <tr><td>20</td><td>*</td><td>18</td><td>17</td><td>*</td><td>*</td><td>*</td><td>*</td><td>*</td><td>*</td></tr> <tr><td>10</td><td>*</td><td>8</td><td>7</td><td>*</td><td>*</td><td>*</td><td>*</td><td>*</td><td>*</td></tr> </table> <p style="text-align: center;">AMP_ECU_40F_B_134</p>	40	39	38	37	36	*	*	*	*	*	*	29	*	*	*	25	24	23	22	*	20	*	18	17	*	*	*	*	*	*	10	*	8	7	*	*	*	*	*	*	<p>C113-1</p> <table border="1" style="width:100%; border-collapse: collapse; text-align: center;"> <tr><td>*</td><td>*</td><td>*</td><td>9</td><td>10</td><td>11</td><td>12</td><td>13</td><td>14</td><td>15</td><td>16</td><td>17</td><td>18</td><td>19</td><td>20</td><td>21</td><td>*</td><td>23</td><td>24</td><td>5</td><td>4</td></tr> <tr><td>*</td><td>*</td><td>*</td><td>*</td><td>*</td><td>*</td><td>*</td><td>*</td><td>*</td><td>*</td><td>*</td><td>*</td><td>*</td><td>*</td><td>*</td><td>40</td><td>*</td><td>*</td><td>*</td><td colspan="2" rowspan="3" style="text-align: center; vertical-align: middle;">3</td></tr> <tr><td>*</td><td>*</td><td>*</td><td>47</td><td>48</td><td>49</td><td>*</td><td>51</td><td>52</td><td>53</td><td>54</td><td>*</td><td>56</td><td>*</td><td>58</td><td>59</td><td>60</td><td>61</td><td>62</td></tr> <tr><td>*</td><td>*</td><td>*</td><td>*</td><td>*</td><td>*</td><td>*</td><td>*</td><td>*</td><td>*</td><td>*</td><td>74</td><td>75</td><td>76</td><td>77</td><td>78</td><td>79</td><td>80</td><td>81</td><td>2</td><td>1</td></tr> </table> <p style="text-align: right;">KET_ECU_81F</p>	*	*	*	9	10	11	12	13	14	15	16	17	18	19	20	21	*	23	24	5	4	*	*	*	*	*	*	*	*	*	*	*	*	*	*	*	40	*	*	*	3		*	*	*	47	48	49	*	51	52	53	54	*	56	*	58	59	60	61	62	*	*	*	*	*	*	*	*	*	*	*	74	75	76	77	78	79	80	81	2	1
24	23	22	21	20	19																																																																																																																																															
18	17	16	15	14	13																																																																																																																																															
*	*	*	*	*	7																																																																																																																																															
*	*	*	*	*	1																																																																																																																																															
40	39	38	37	36	*	*	*	*	*																																																																																																																																											
*	29	*	*	*	25	24	23	22	*																																																																																																																																											
20	*	18	17	*	*	*	*	*	*																																																																																																																																											
10	*	8	7	*	*	*	*	*	*																																																																																																																																											
*	*	*	9	10	11	12	13	14	15	16	17	18	19	20	21	*	23	24	5	4																																																																																																																																
*	*	*	*	*	*	*	*	*	*	*	*	*	*	*	40	*	*	*	3																																																																																																																																	
*	*	*	47	48	49	*	51	52	53	54	*	56	*	58	59	60	61	62																																																																																																																																		
*	*	*	*	*	*	*	*	*	*	*	74	75	76	77	78	79	80	81			2	1																																																																																																																														
<p>C134/C234</p>  <p style="text-align: center;">PRONER_980103_89129</p>	<p>C153/C253</p> 	<p>E19</p>  <p style="text-align: center;">AMP_EJMP_04F_B</p>	<p>E104/E204</p>  <p style="text-align: center;">KUM_NMWP_01F_B</p>																																																																																																																																																	
<p>I30</p>  <p style="text-align: center;">KUM_PH776_02025</p>	<p>I31</p>  <p style="text-align: center;">KET_MG612109</p>	<p>I32</p>  <p style="text-align: center;">KUM_PH776_04027</p>	<p>I33</p>  <p style="text-align: center;">KUM_PH845_07020</p>																																																																																																																																																	
<p>I35/I37</p>  <p style="text-align: center;">KUM_PH845_07020</p>	<p>I36</p>  <p style="text-align: center;">AMP_174463_1</p>	<p>M05-1</p>  <p style="text-align: center;">AMP_040M1_12F_B</p>	<p>M05-2</p>  <p style="text-align: center;">AMP_040M1_16F_B</p>																																																																																																																																																	

FRONT WIPER & WASHER

FRONT WIPER & WASHER (2)

SD981-2

C19/C67/C117/C217

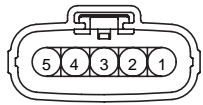

KUM_NDWP_05F_B

E23



KET_090IWP_03F_Gr

M09-1

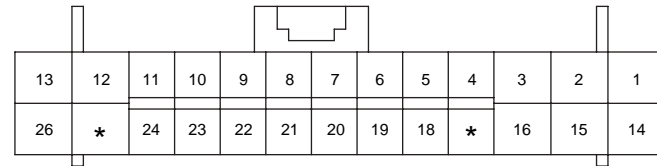

AMP_0407_26F_W_HD

M09-3

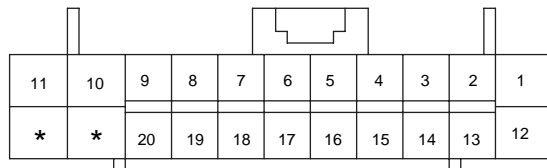

AMP_0407_22F_W_HD

M25-2/M25-2R

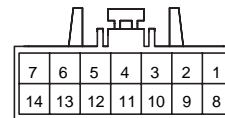

KET_090II_14F_W_SW

BLANK

REAR WIPER & WASHER

REAR WIPER & WASHER (2)

SD982-2

E23



KET_090IWP_03F_B

F29

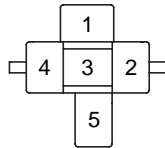

KET_250_05F_B_RLY

M09-1

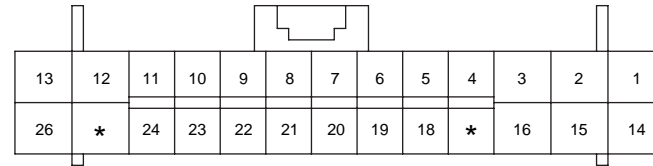

AMP_0407_26F_W_HD

M09-3

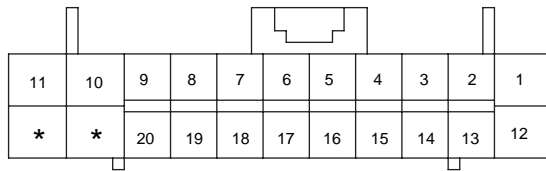

AMP_0407_22F_W_HD

M25-2/M25-2R

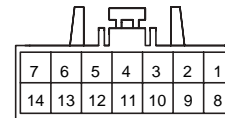

KET_090II_14F_W_SW

R02

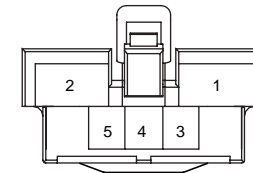

KET_2509_05F_W

R23

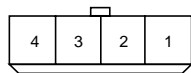

KET_090II_4F

BLANK

BLANK

BLANK

COMPONENT LOCATIONS (1)

CL-1

PHOTO.1

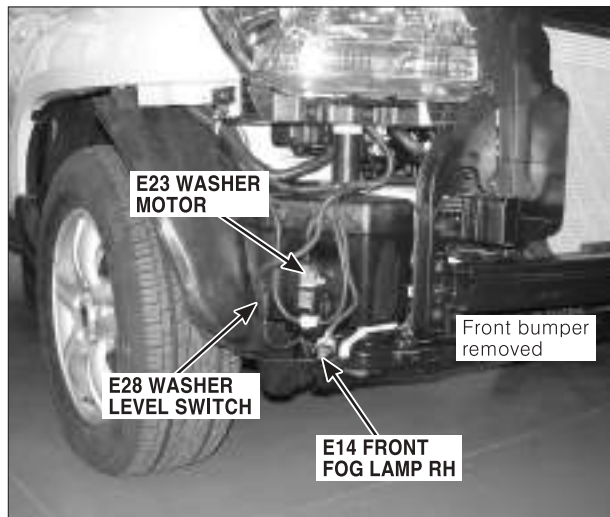

PHOTO.2

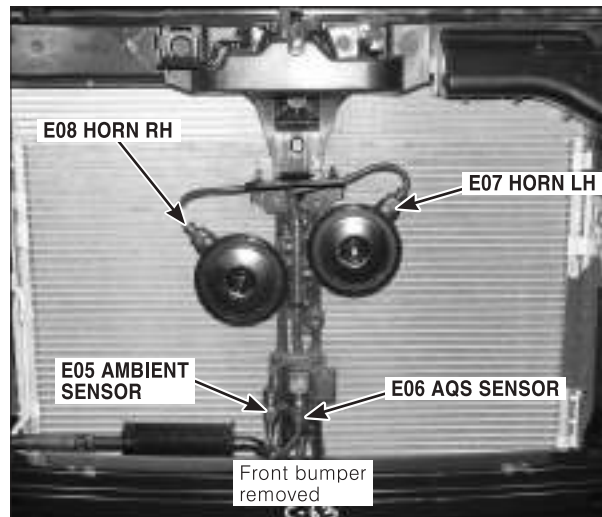

PHOTO.3

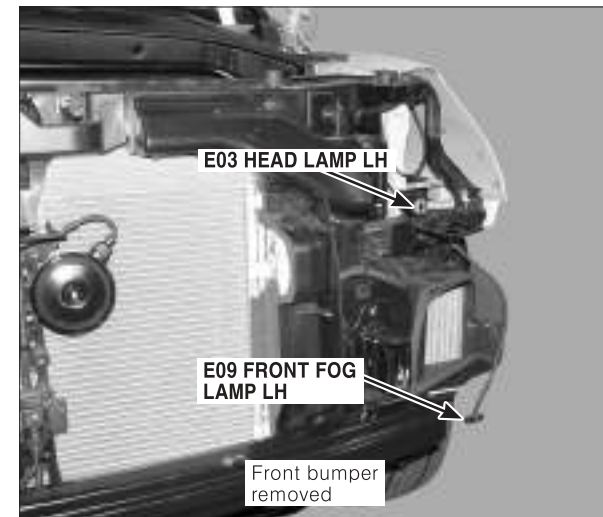

PHOTO.4



PHOTO.5



PHOTO.6

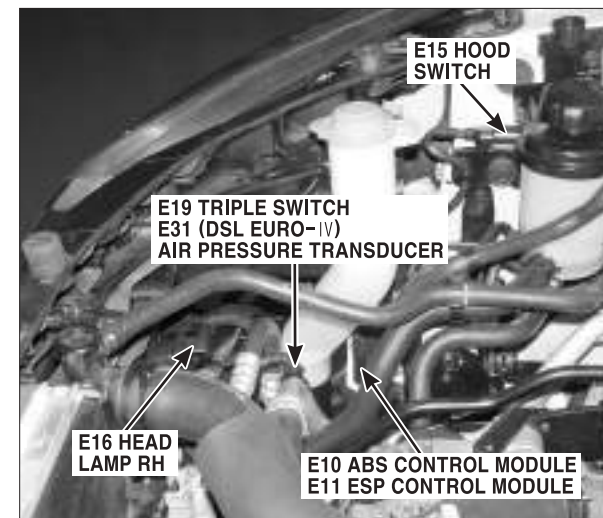

COMPONENT LOCATIONS

COMPONENT LOCATIONS (2)

CL-2

PHOTO.7

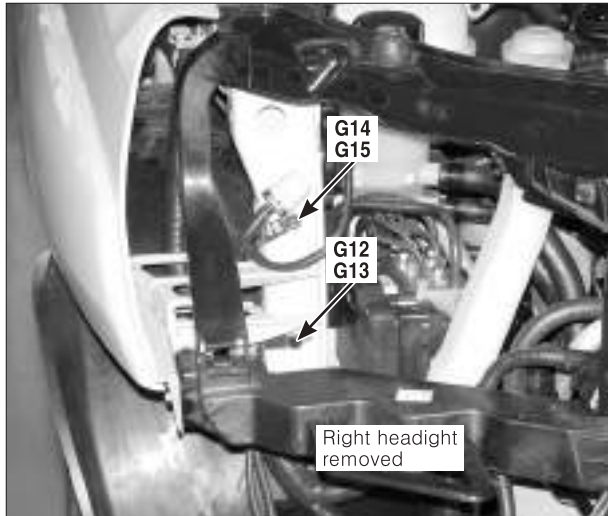

PHOTO.8

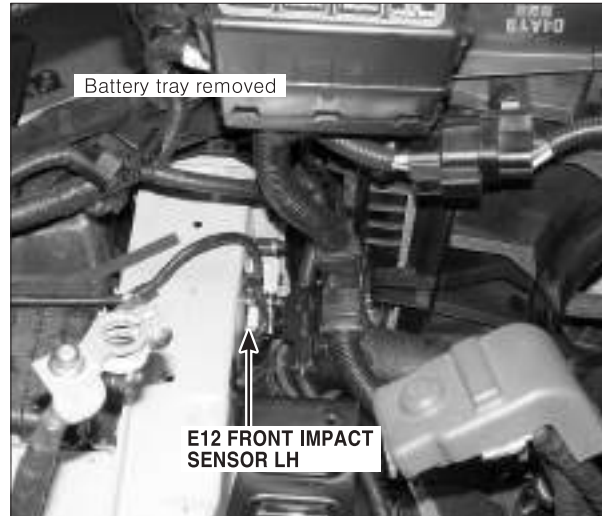

PHOTO.9

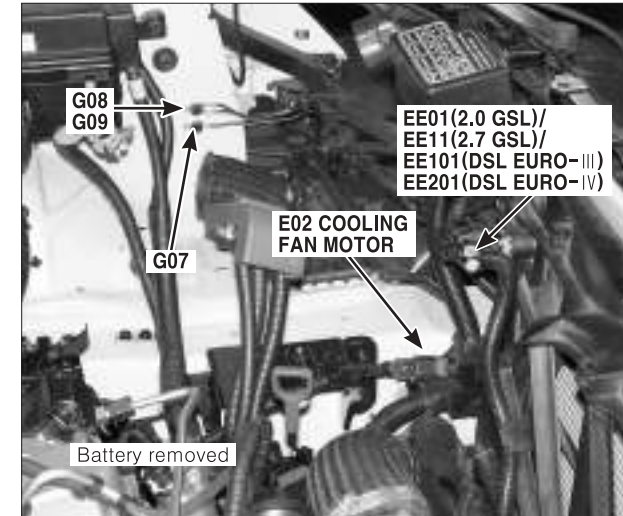

PHOTO.10

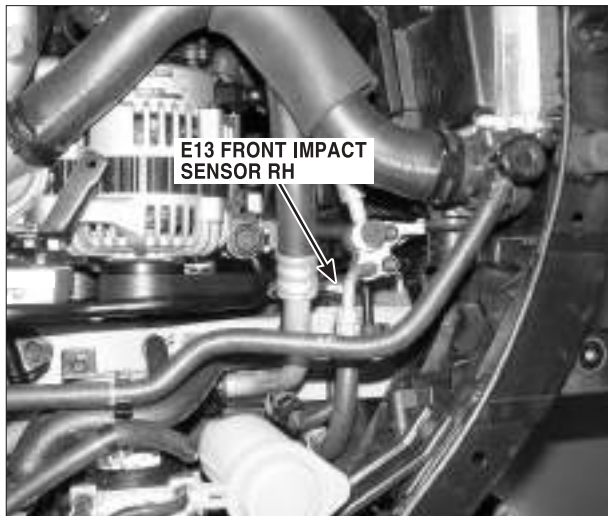
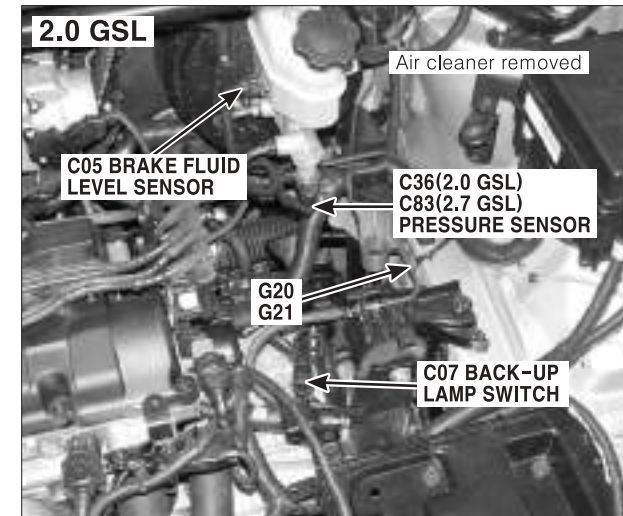

PHOTO.11



PHOTO.12



COMPONENT LOCATIONS

COMPONENT LOCATIONS (3)

CL-3

PHOTO.13

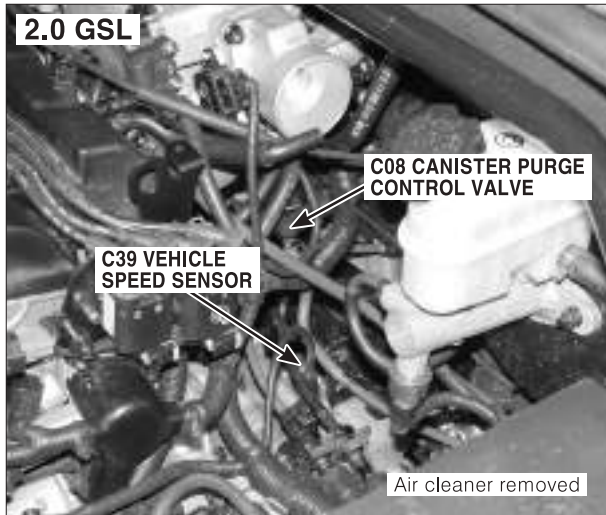

PHOTO.14

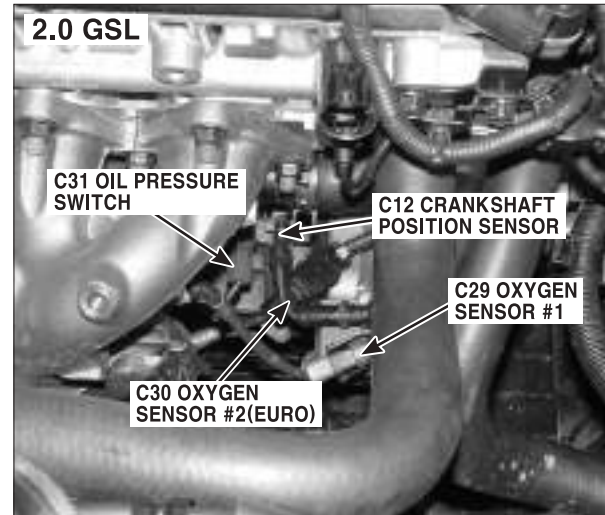

PHOTO.15



PHOTO.16

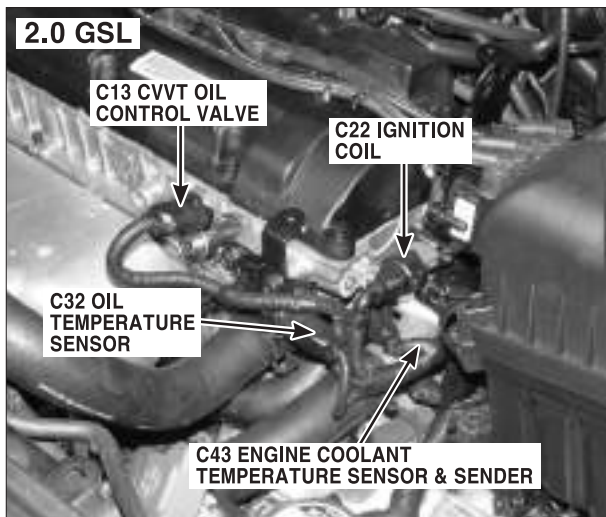

PHOTO.17

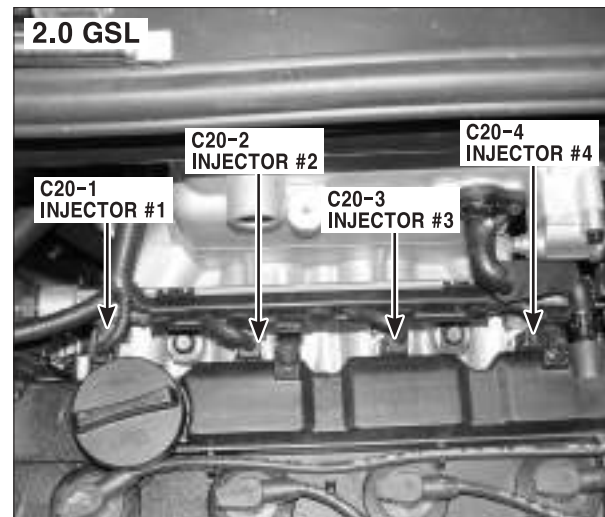
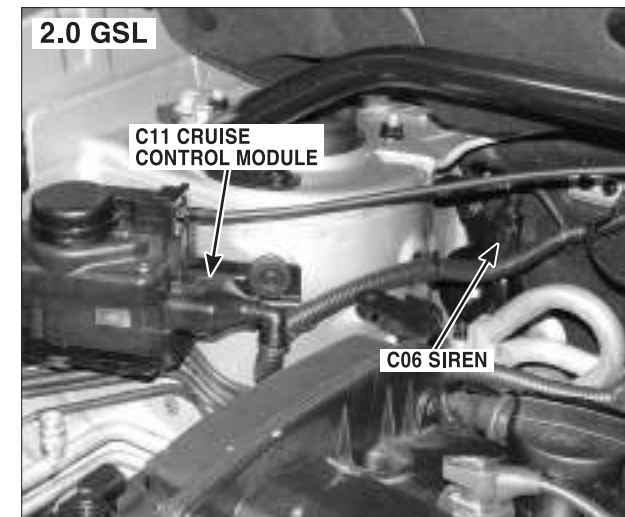

PHOTO.18



COMPONENT LOCATIONS

COMPONENT LOCATIONS (4)

CL-4

PHOTO.19

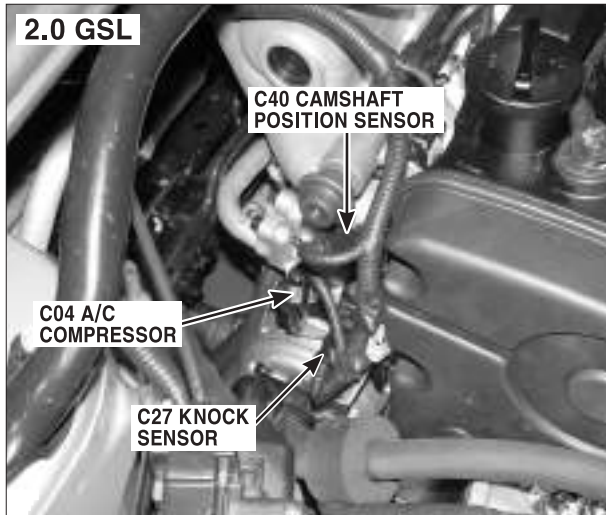

PHOTO.20

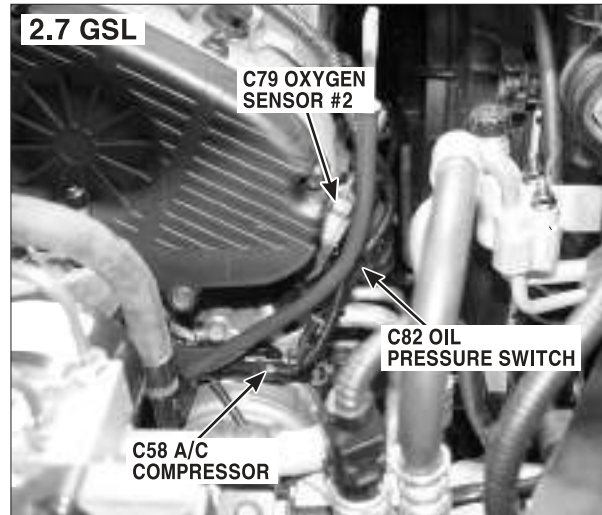

PHOTO.21

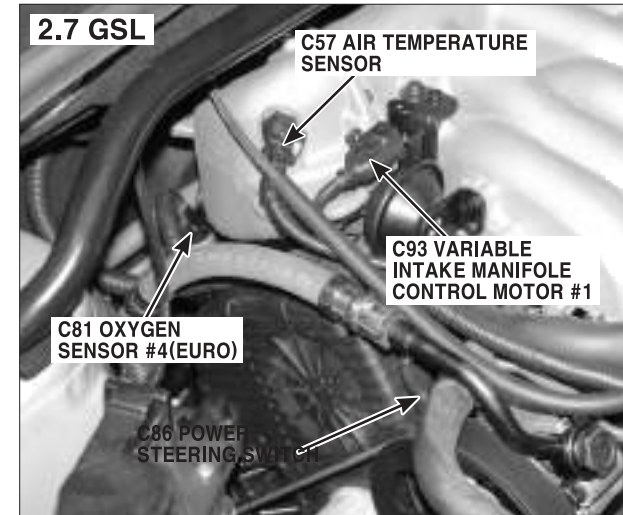

PHOTO.22

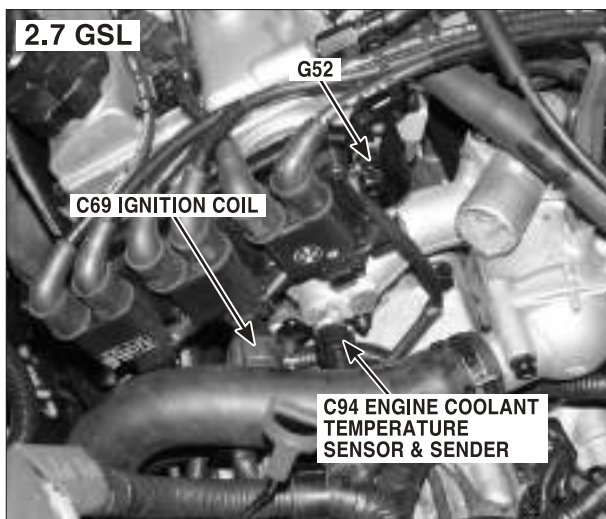

PHOTO.23

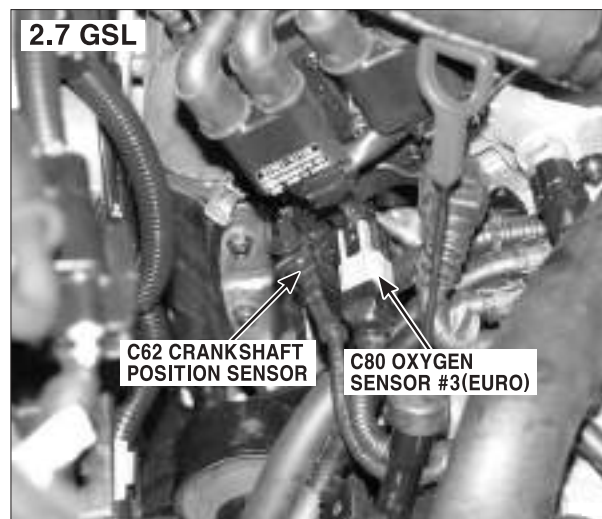
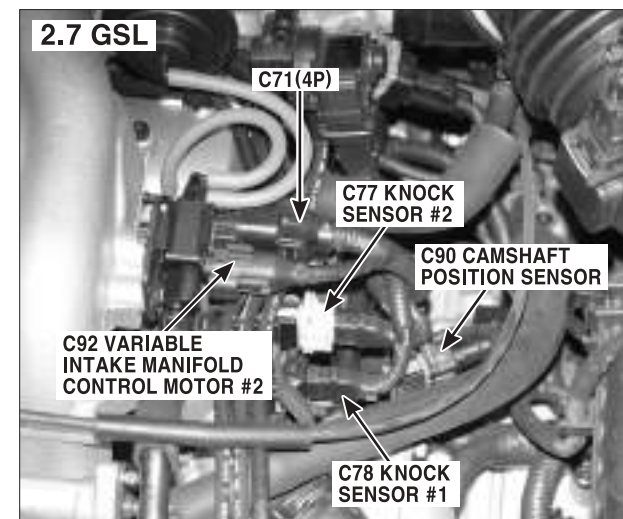

PHOTO.24



COMPONENT LOCATIONS

COMPONENT LOCATIONS (5)

CL-5

PHOTO.25

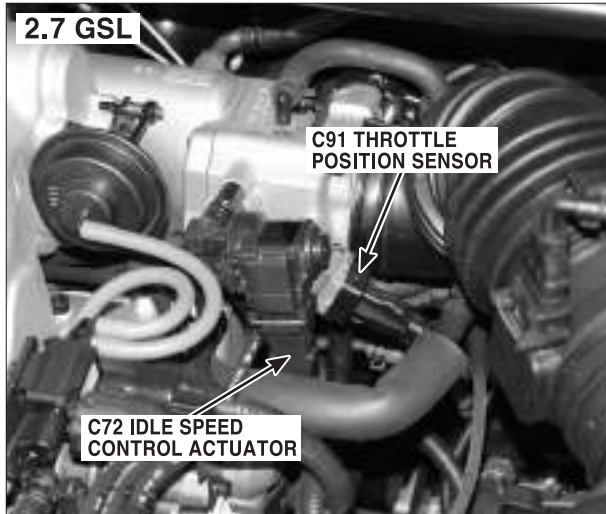

PHOTO.26



PHOTO.27

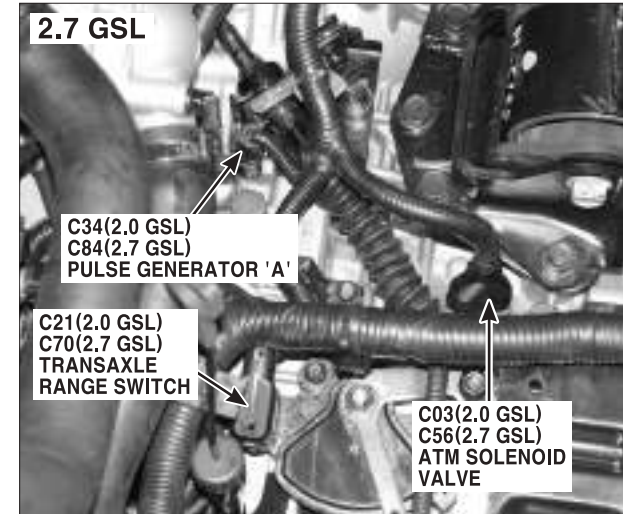

PHOTO.28

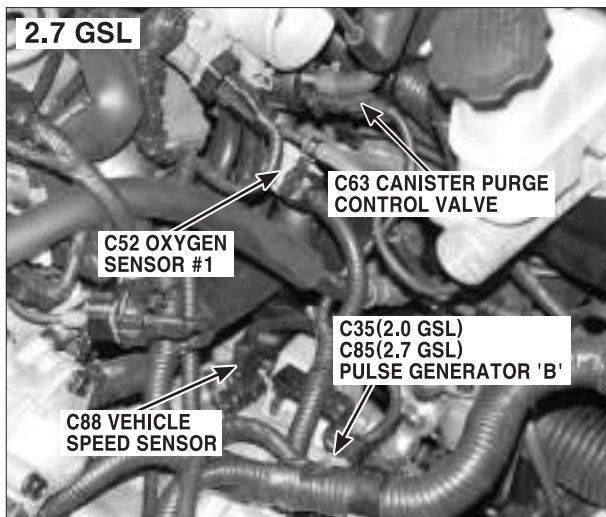

PHOTO.29

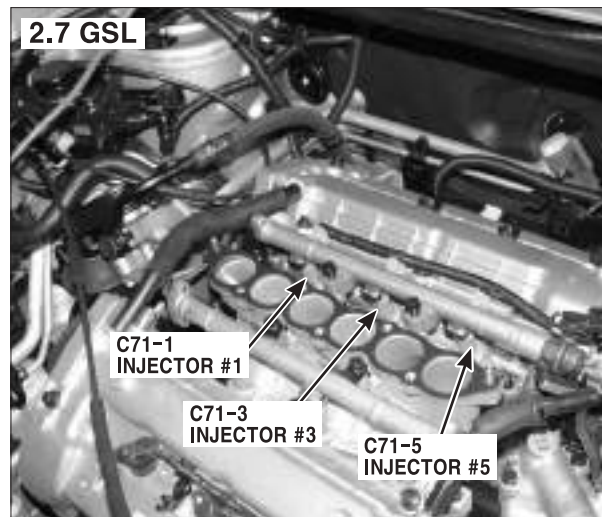
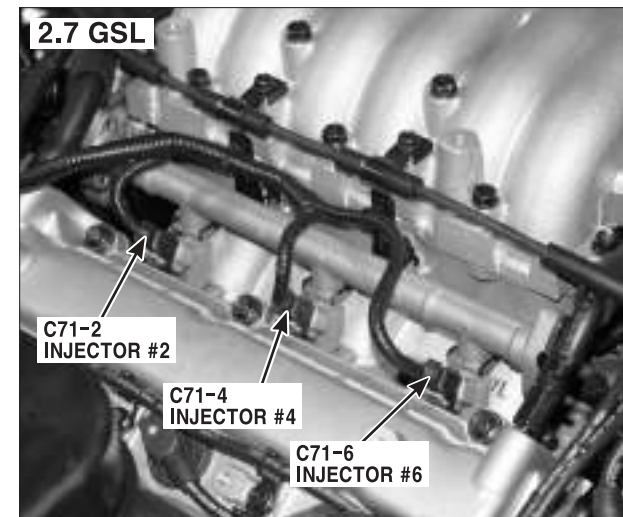

PHOTO.30



COMPONENT LOCATIONS

COMPONENT LOCATIONS (6)

CL-6

PHOTO.31

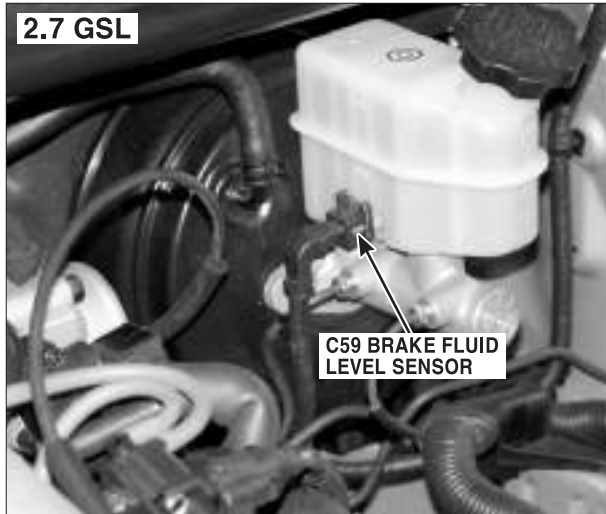

PHOTO.32

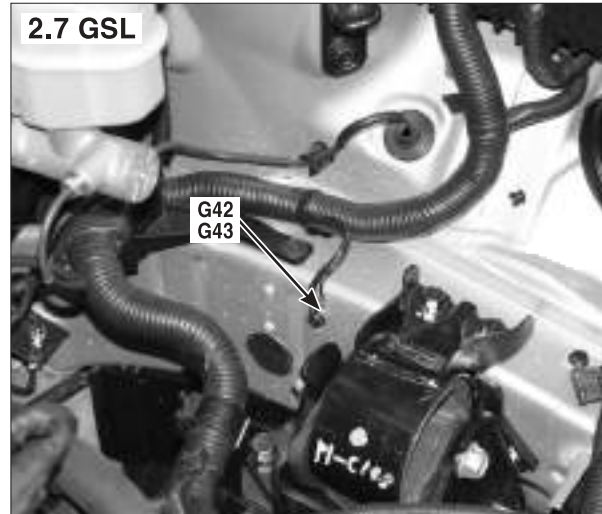

PHOTO.33



PHOTO.34

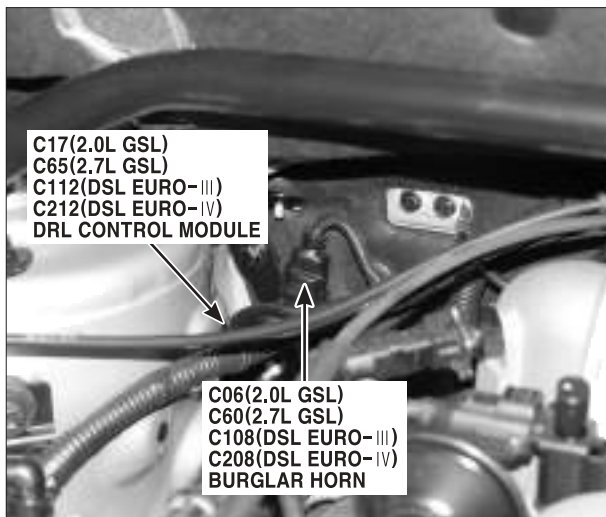

PHOTO.35

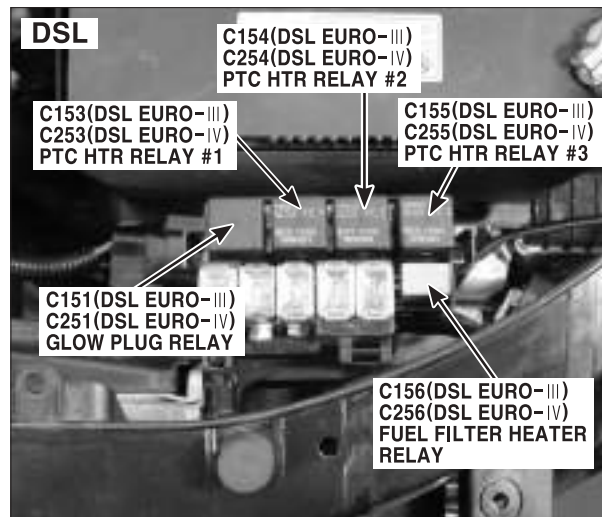
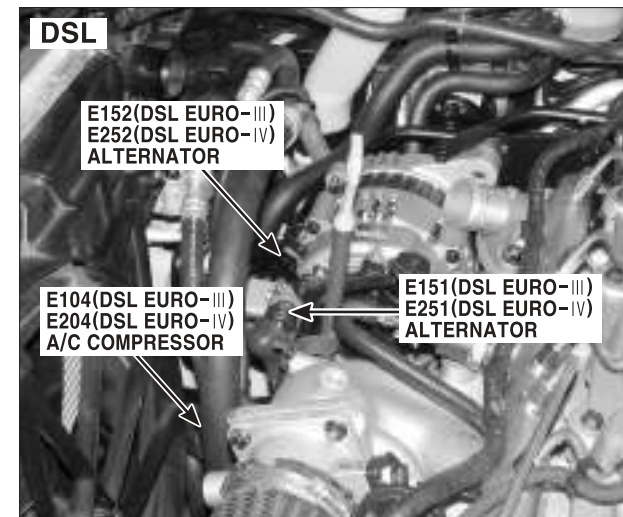

PHOTO.36



COMPONENT LOCATIONS

COMPONENT LOCATIONS (7)

CL-7

PHOTO.37

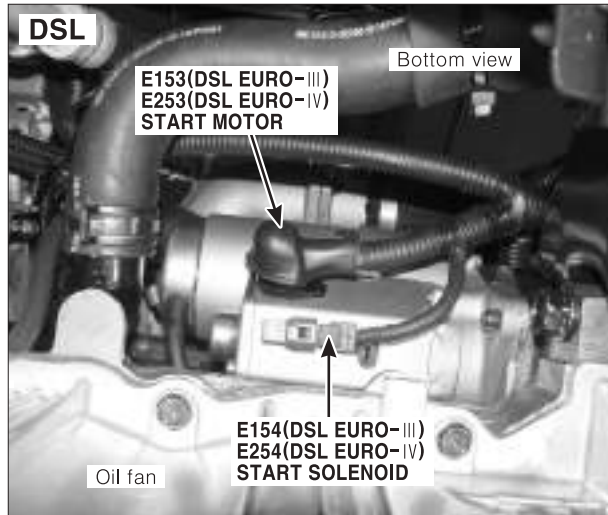

PHOTO.38

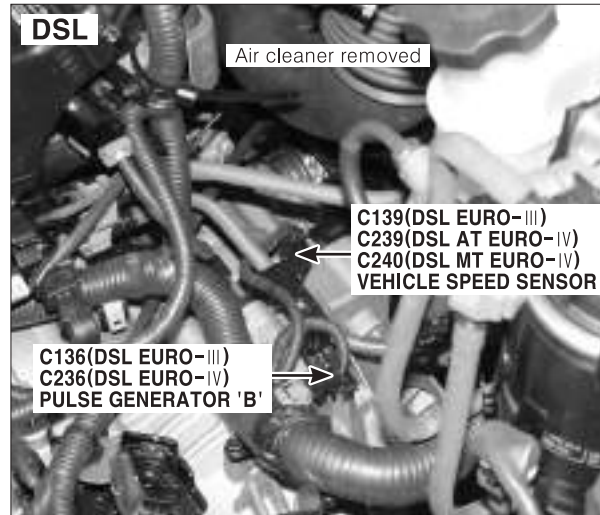

PHOTO.39

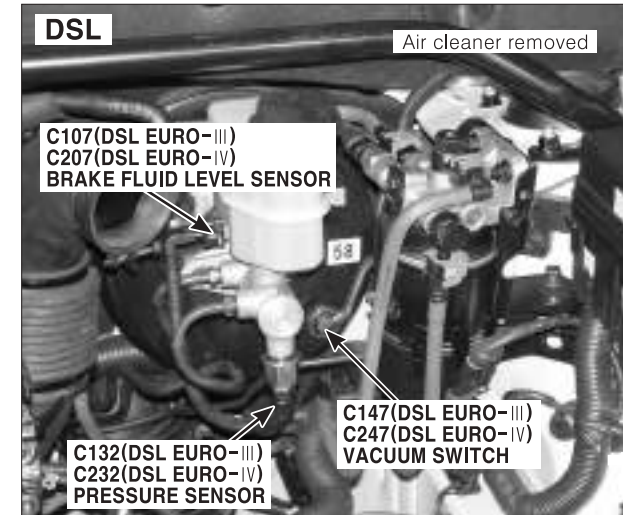

PHOTO.40

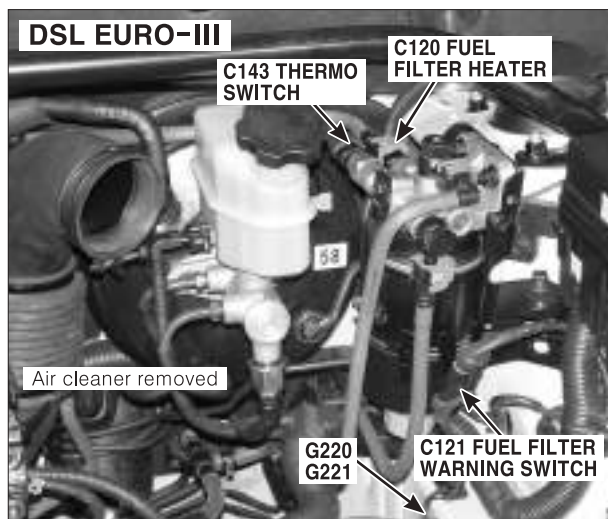

PHOTO.41

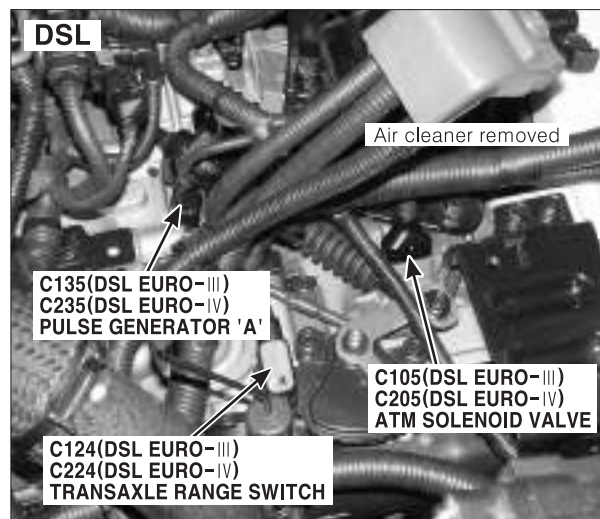
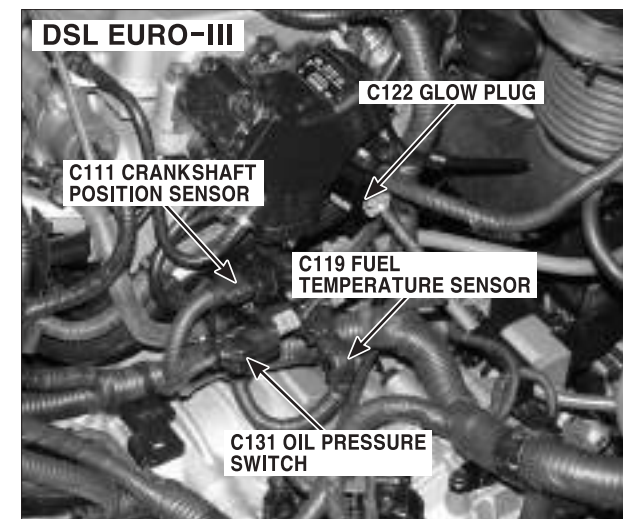

PHOTO.42



COMPONENT LOCATIONS

COMPONENT LOCATIONS (8)

CL-8

PHOTO.43

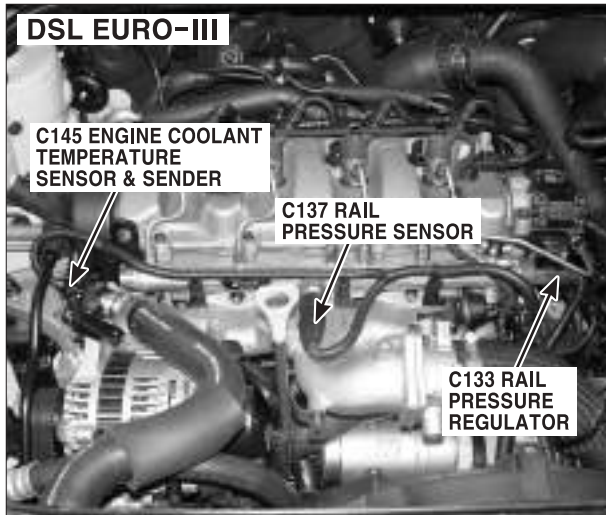

PHOTO.44

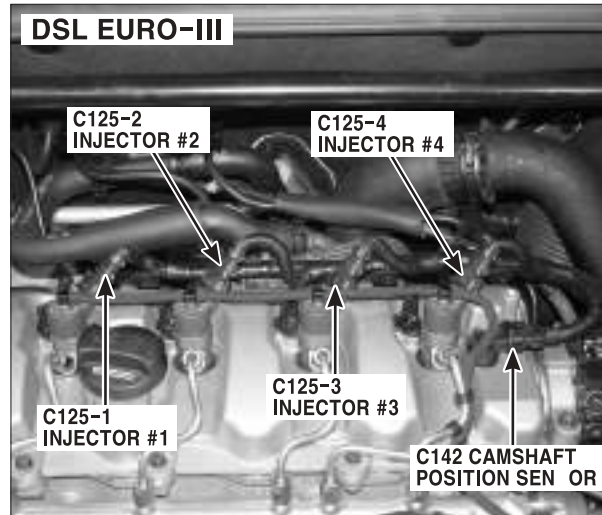

PHOTO.45



PHOTO.46

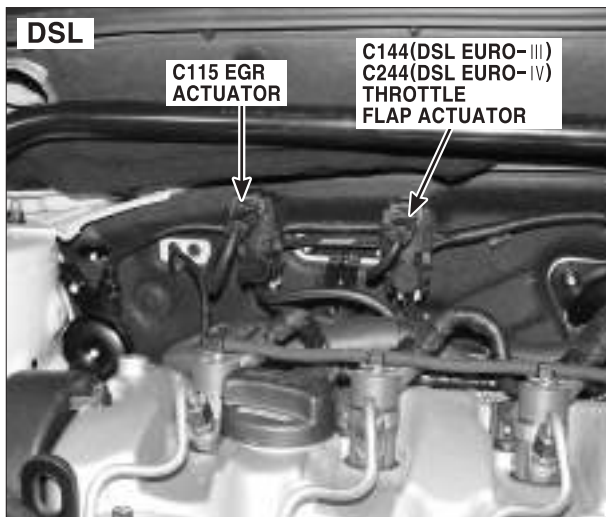

PHOTO.47

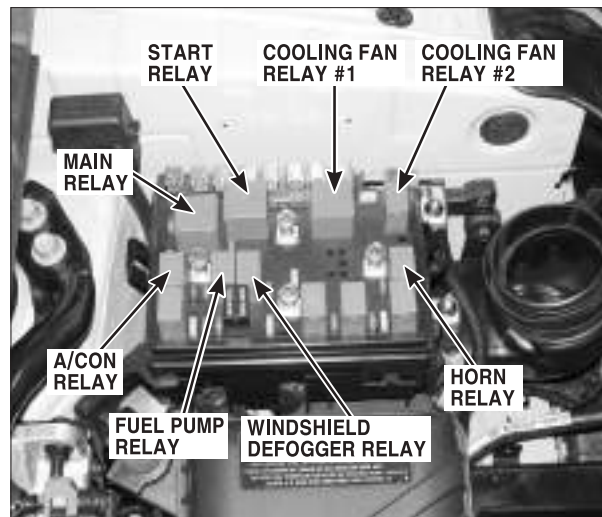
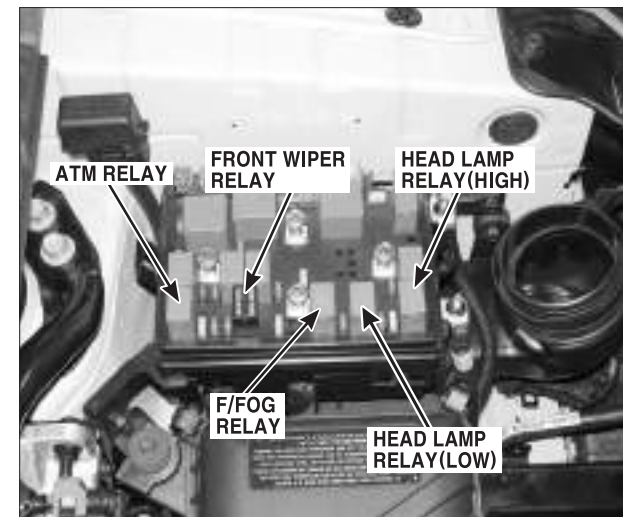

PHOTO.48



COMPONENT LOCATIONS

COMPONENT LOCATIONS (9)

CL-9

PHOTO.49

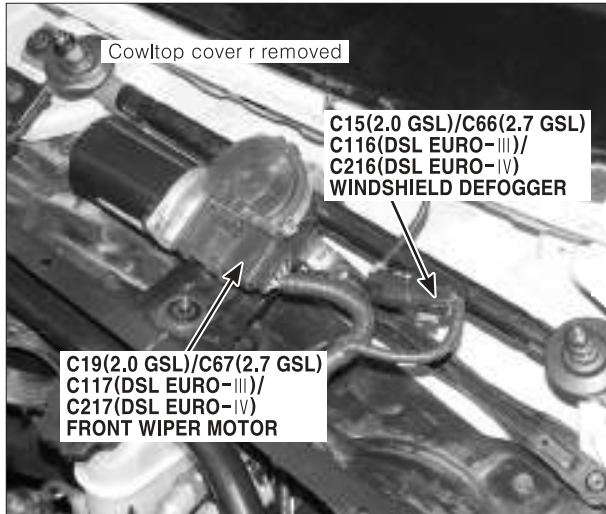

PHOTO.50

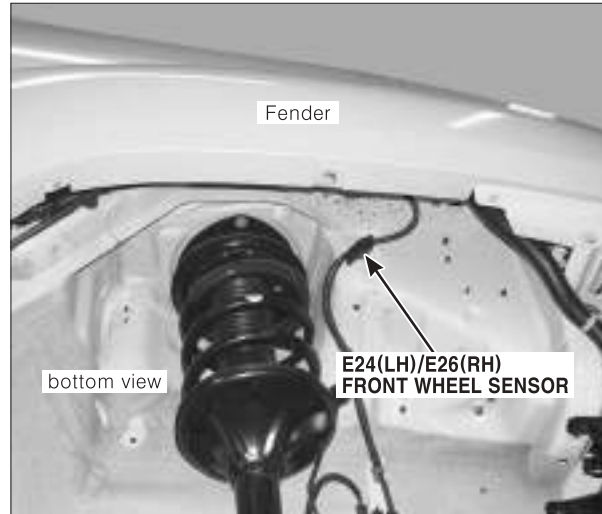

PHOTO.51



PHOTO.52

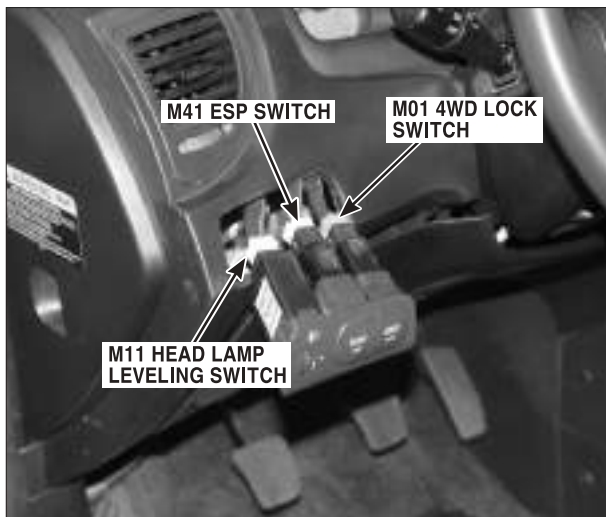
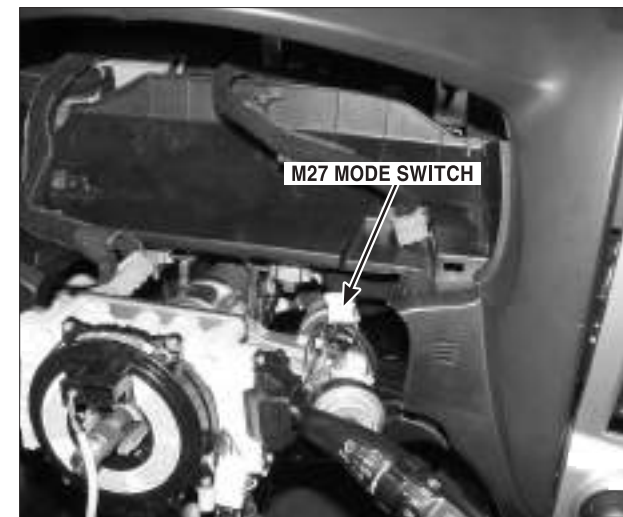

PHOTO.53



PHOTO.54



COMPONENT LOCATIONS

COMPONENT LOCATIONS (10)

CL-10

PHOTO.55

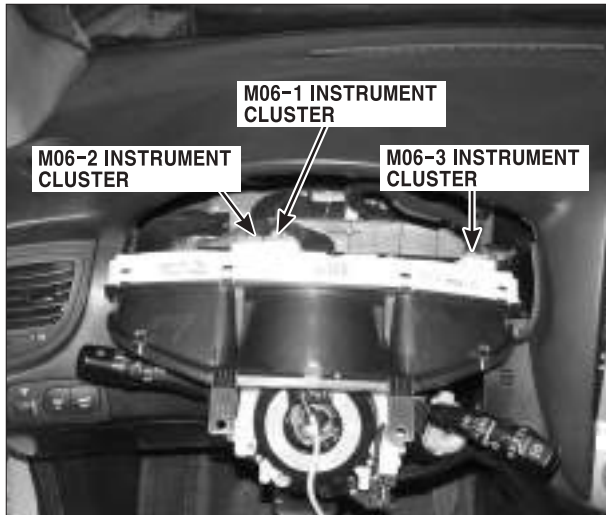

PHOTO.56

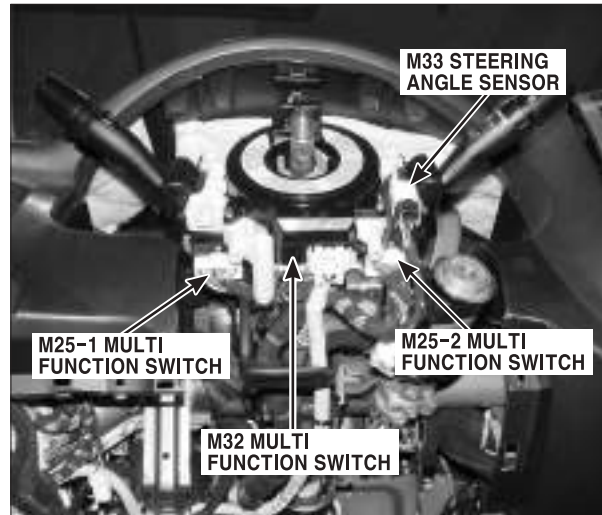

PHOTO.57

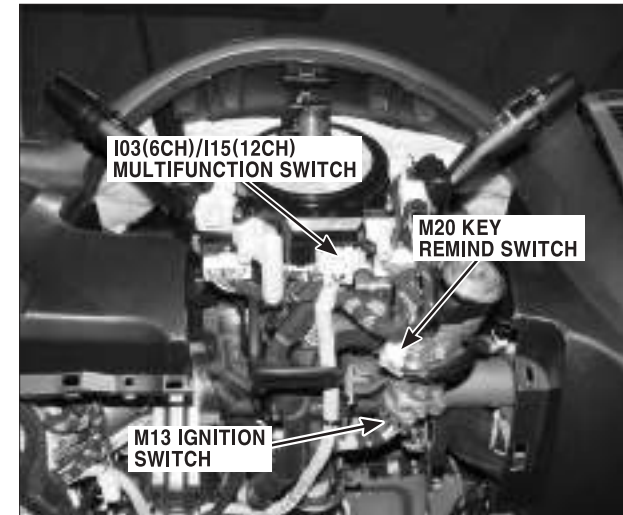

PHOTO.58

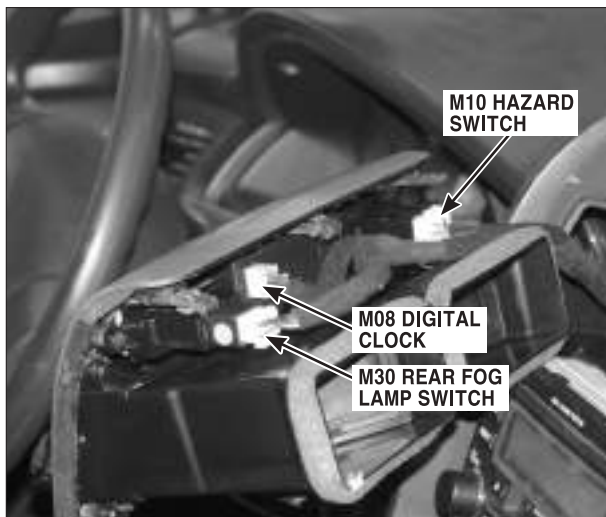

PHOTO.59

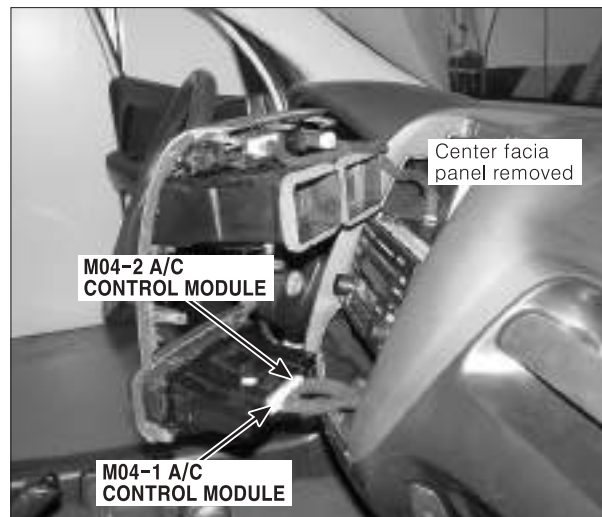
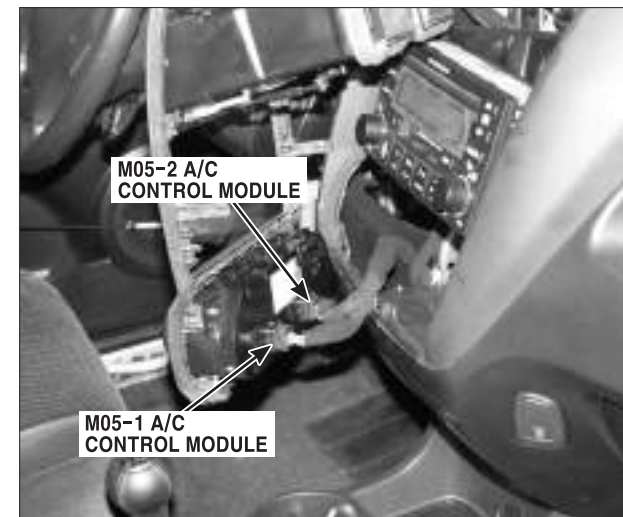

PHOTO.60



COMPONENT LOCATIONS

COMPONENT LOCATIONS (11)

CL-11

PHOTO.61

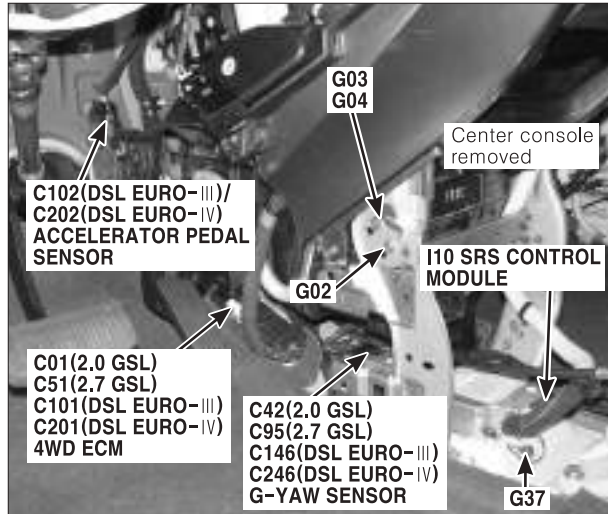

PHOTO.62

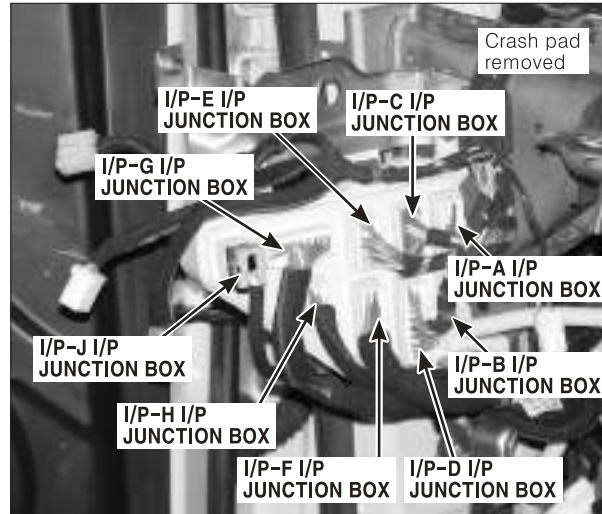

PHOTO.63

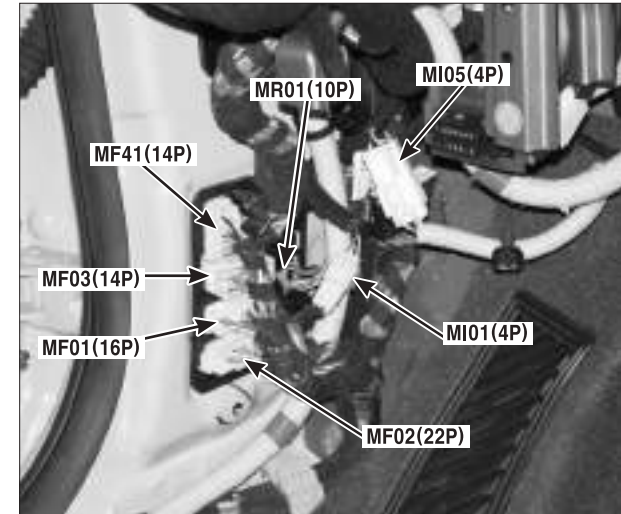

PHOTO.64

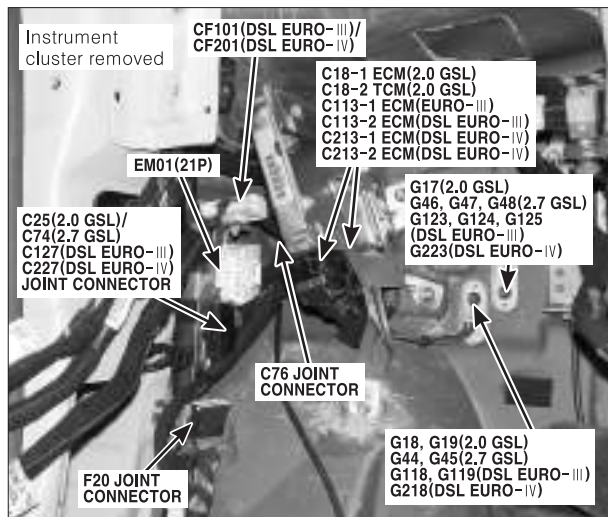

PHOTO.65

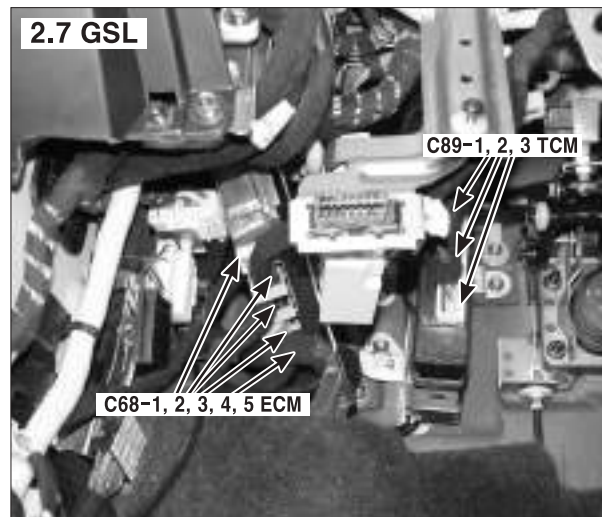
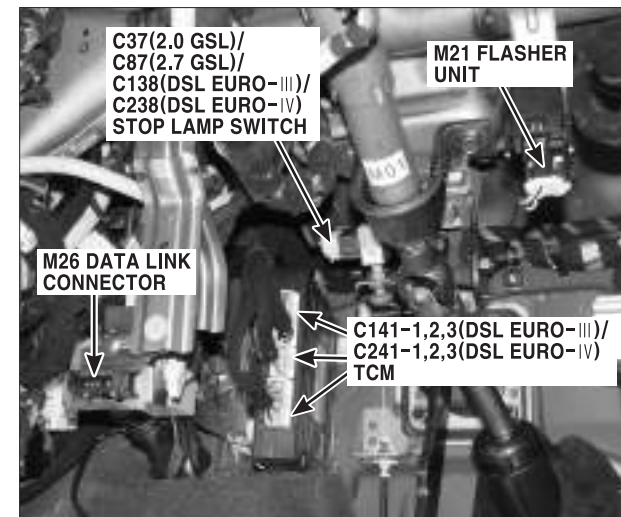

PHOTO.66



COMPONENT LOCATIONS

COMPONENT LOCATIONS (12)

CL-12

PHOTO.67

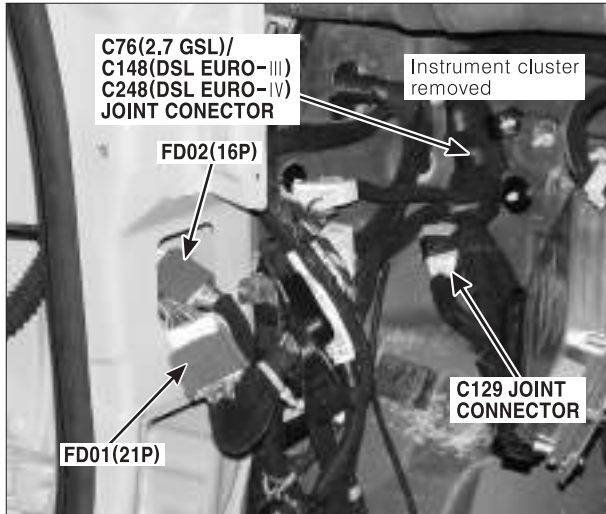

PHOTO.68

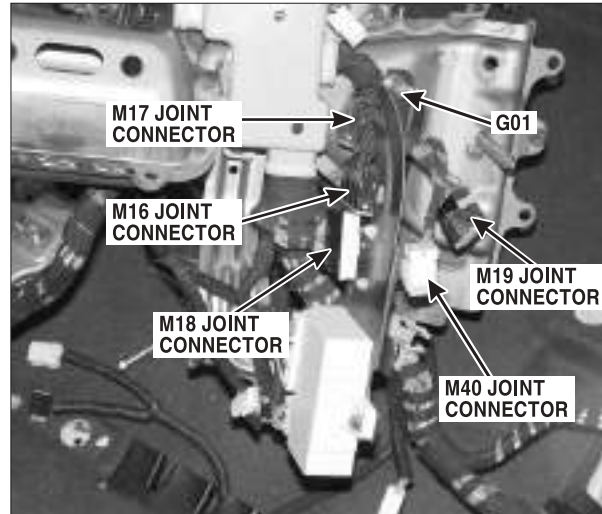

PHOTO.69

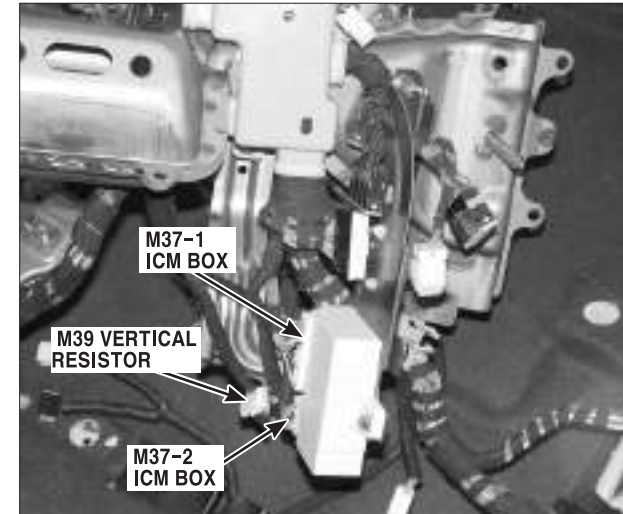

PHOTO.70



PHOTO.71

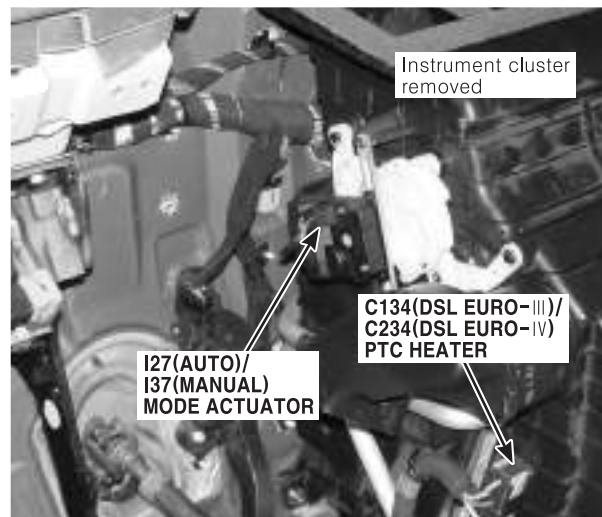
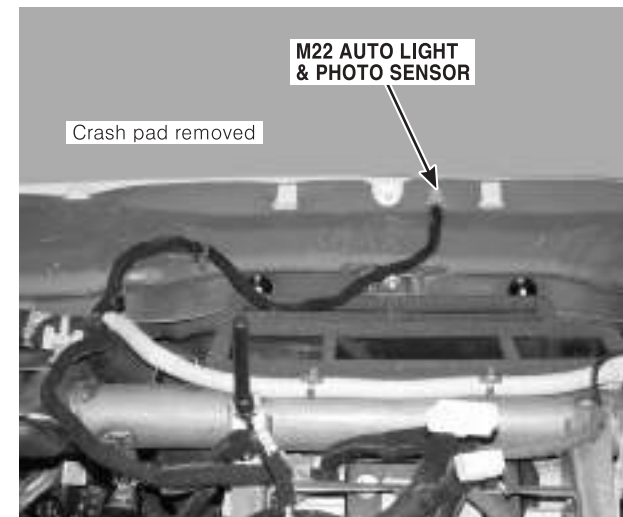

PHOTO.72



COMPONENT LOCATIONS

COMPONENT LOCATIONS (13)

CL-13

PHOTO.73



PHOTO.74

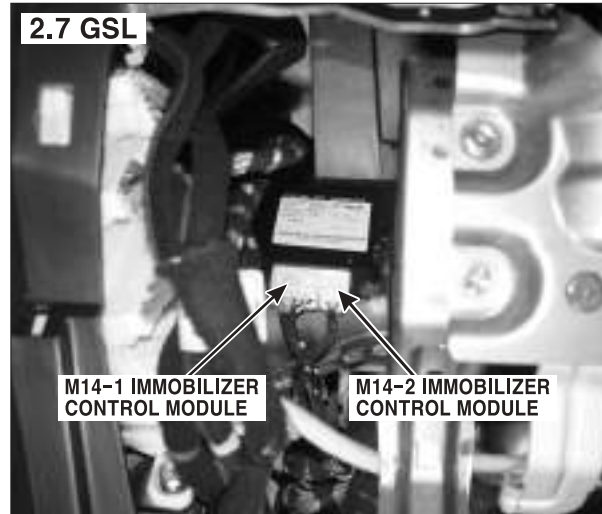

PHOTO.75

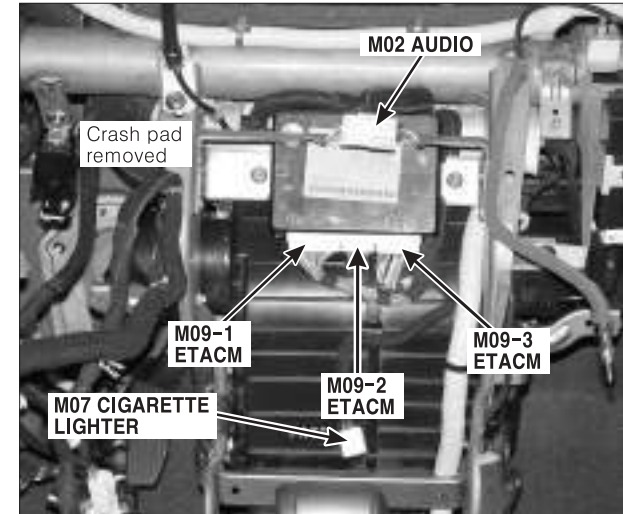

PHOTO.76

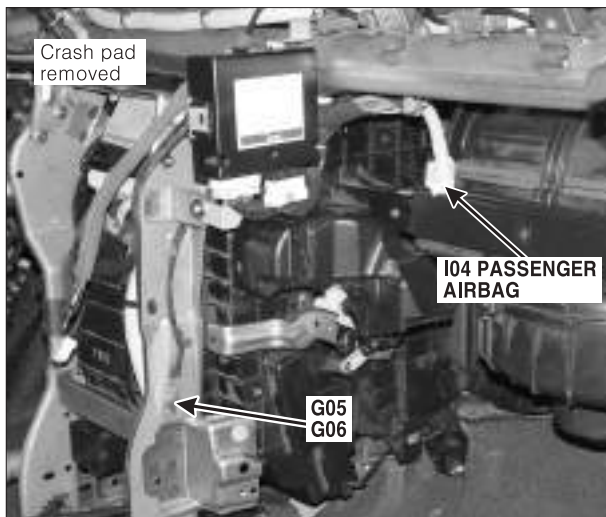

PHOTO.77

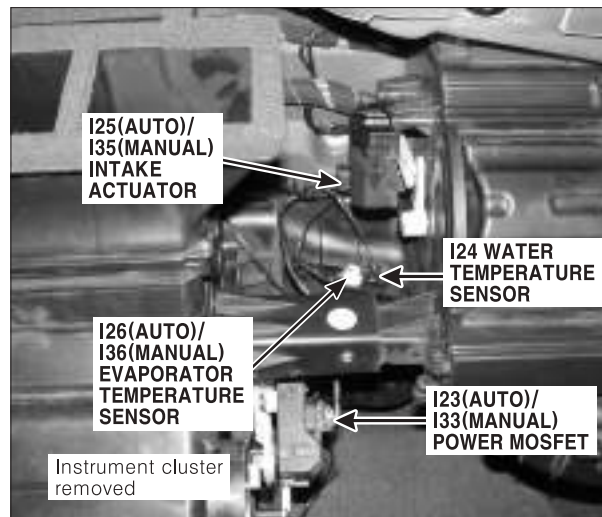
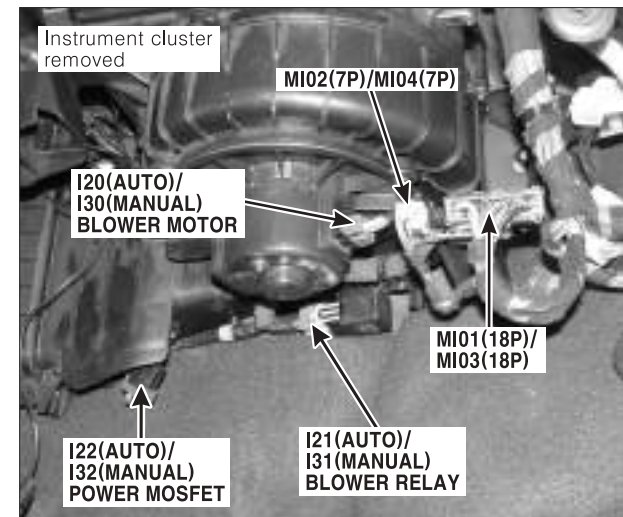

PHOTO.78



COMPONENT LOCATIONS

COMPONENT LOCATIONS (14)

CL-14

PHOTO.79

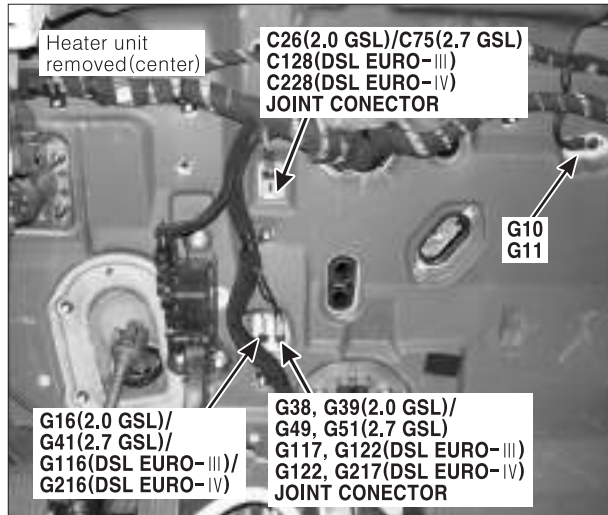

PHOTO.80

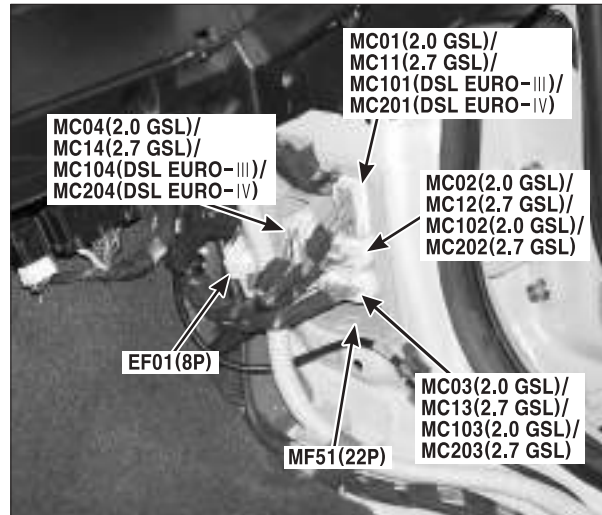

PHOTO.81

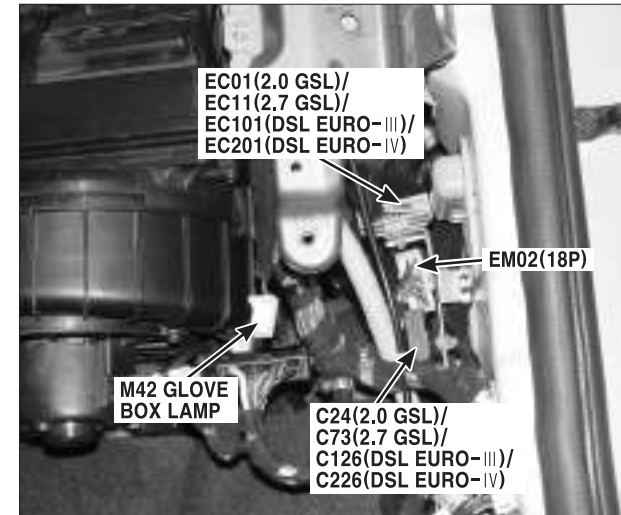

PHOTO.82

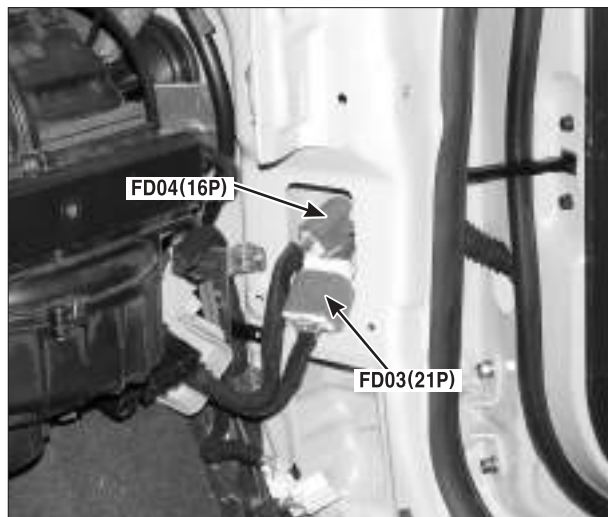

PHOTO.83

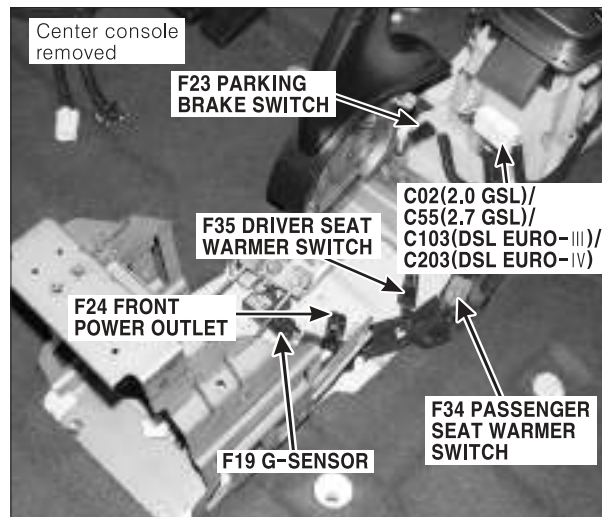
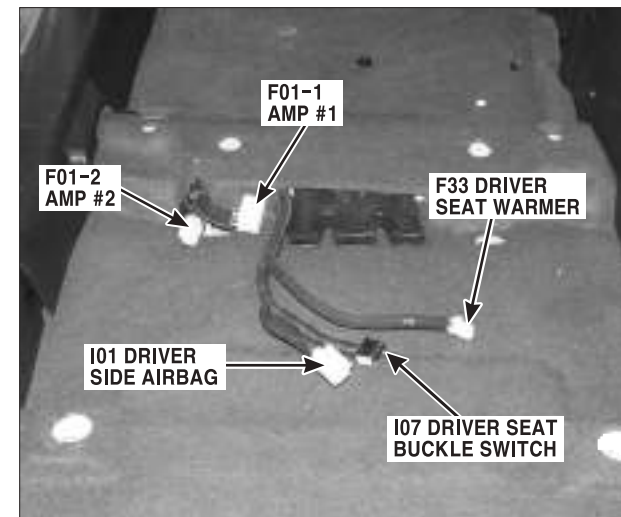

PHOTO.84



COMPONENT LOCATIONS

COMPONENT LOCATIONS (15)

CL-15

PHOTO.85

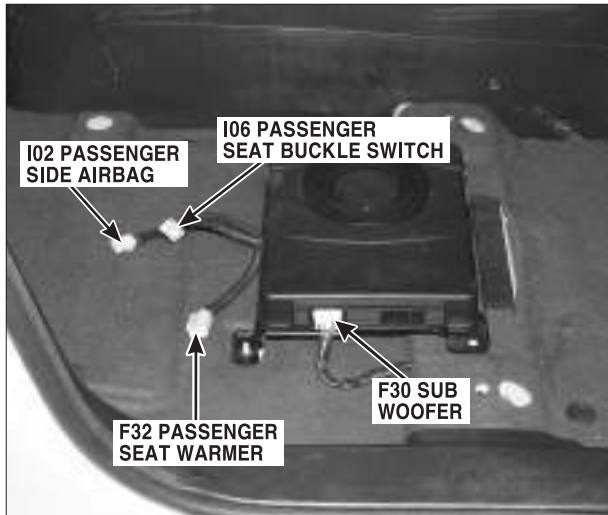

PHOTO.86

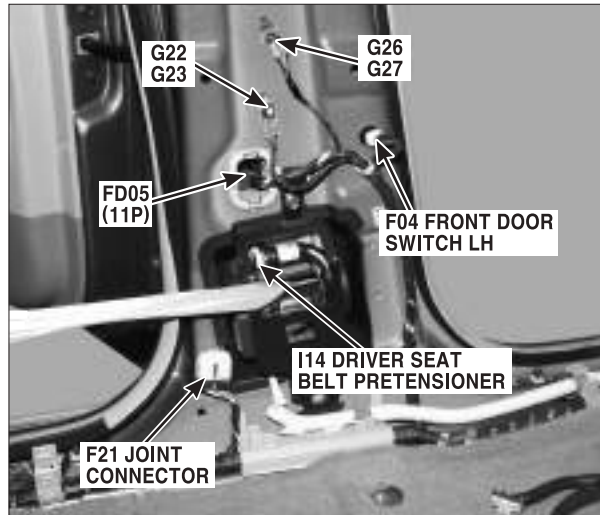

PHOTO.87

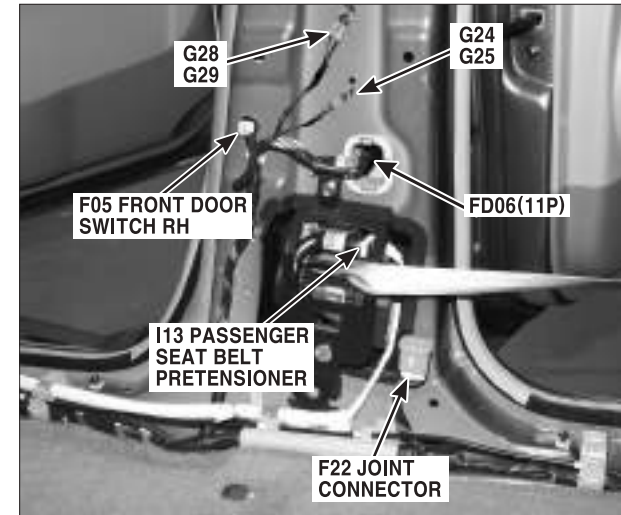

PHOTO.88

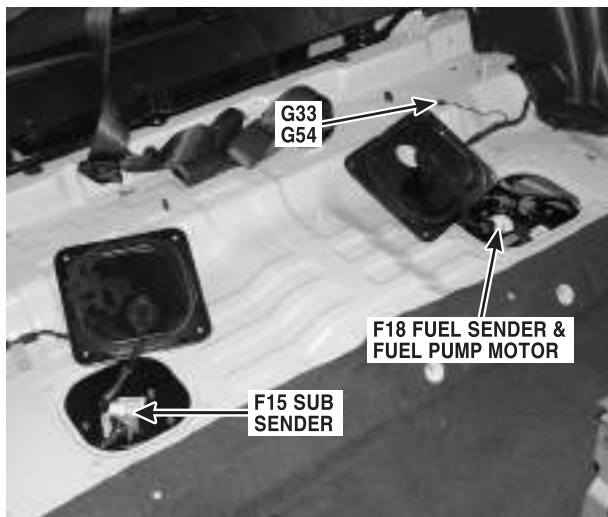

PHOTO.89

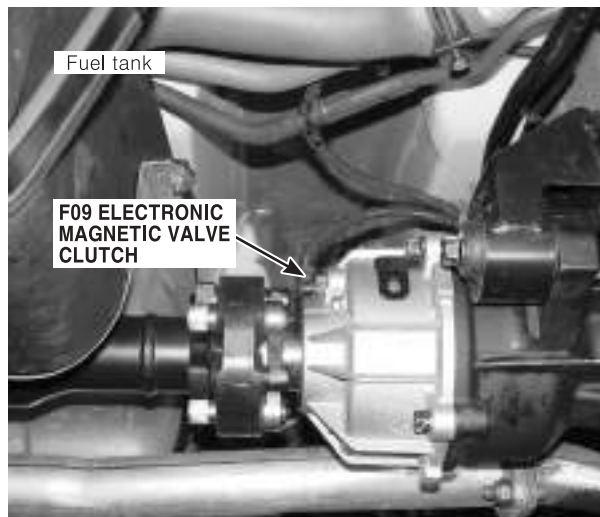
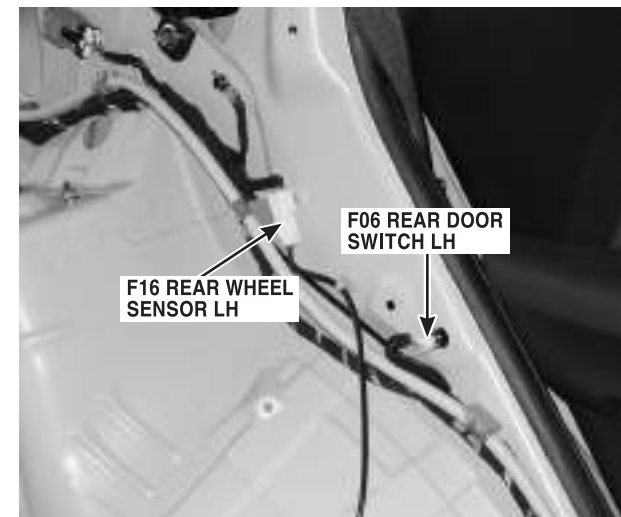

PHOTO.90



COMPONENT LOCATIONS

COMPONENT LOCATIONS (16)

CL-16

PHOTO.91

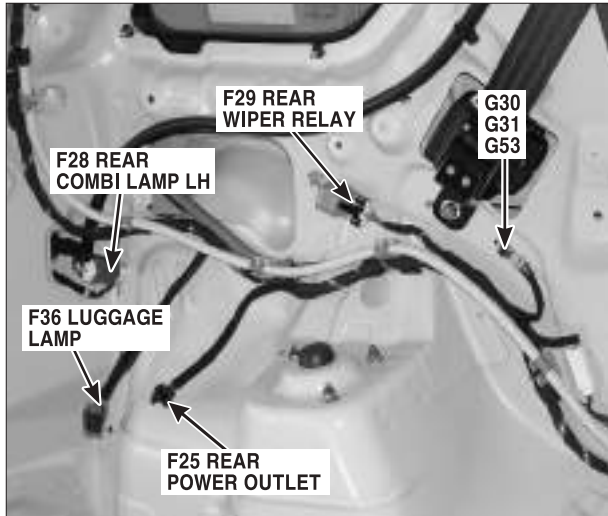

PHOTO.92

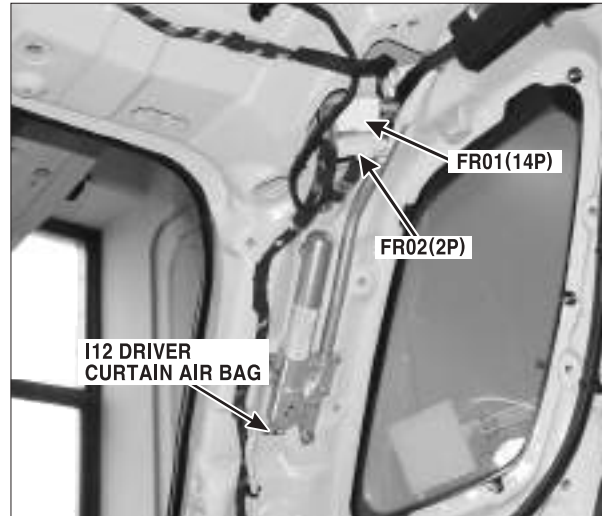

PHOTO.93

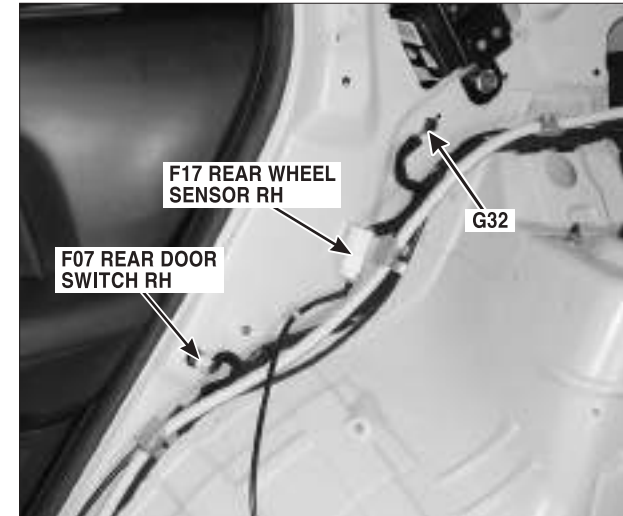

PHOTO.94

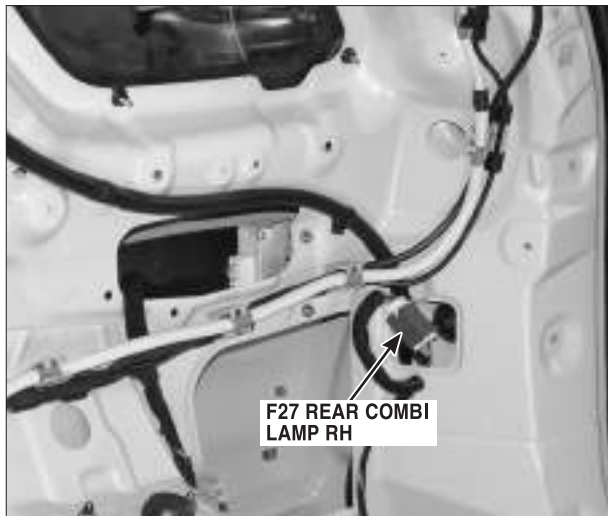

PHOTO.95



PHOTO.96



COMPONENT LOCATIONS

COMPONENT LOCATIONS (17)

CL-17

PHOTO.97

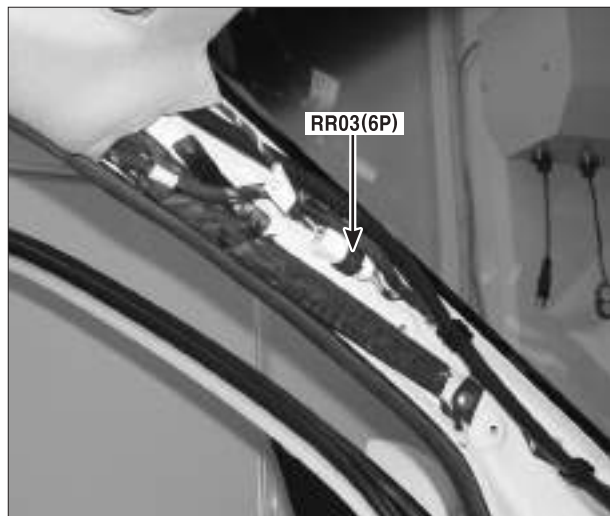

PHOTO.98

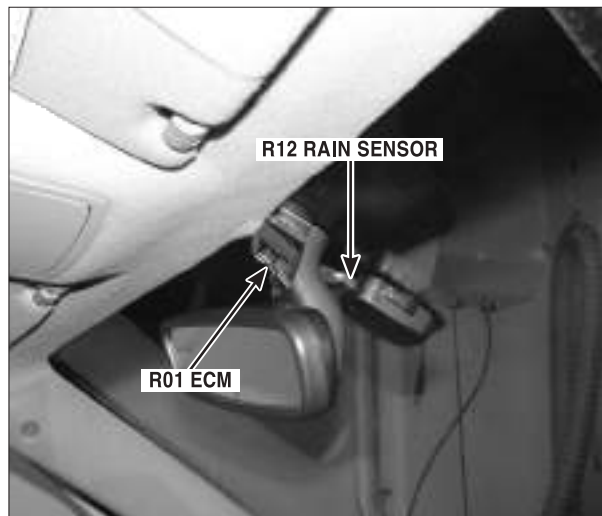

PHOTO.99

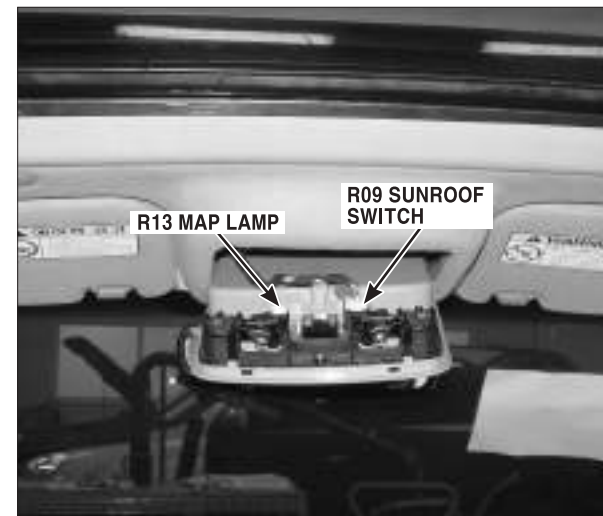

PHOTO.100



PHOTO.101



PHOTO.102



COMPONENT LOCATIONS

COMPONENT LOCATIONS (18)

CL-18

PHOTO.103

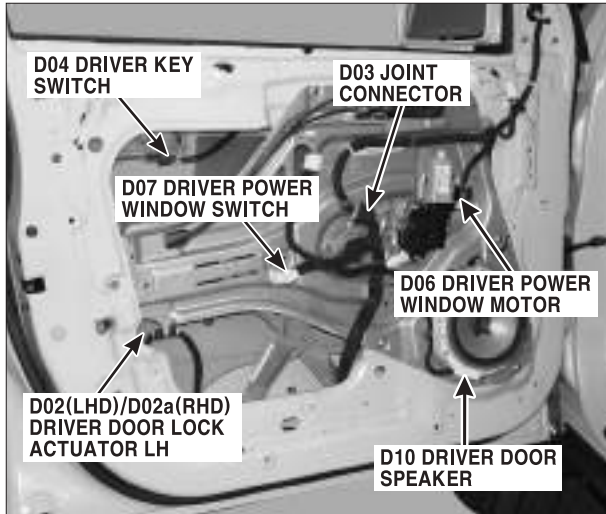

PHOTO.104

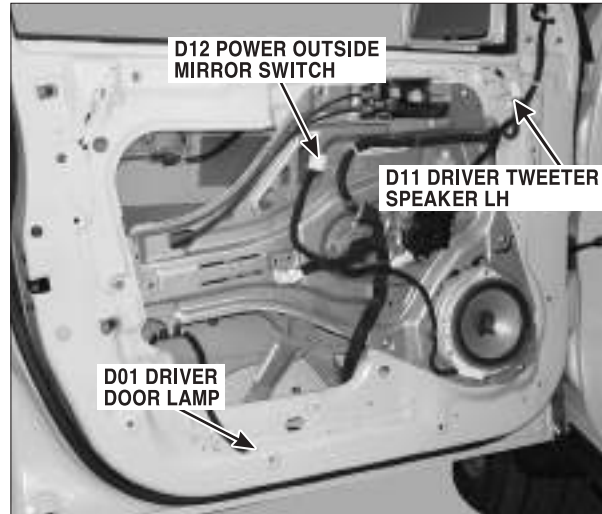

PHOTO.105

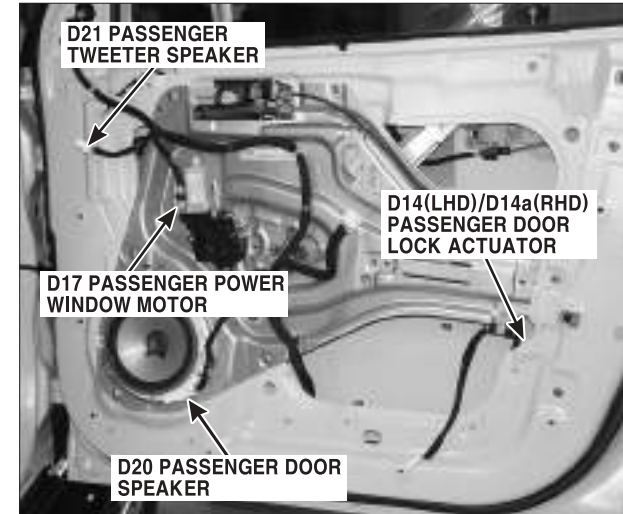

PHOTO.106

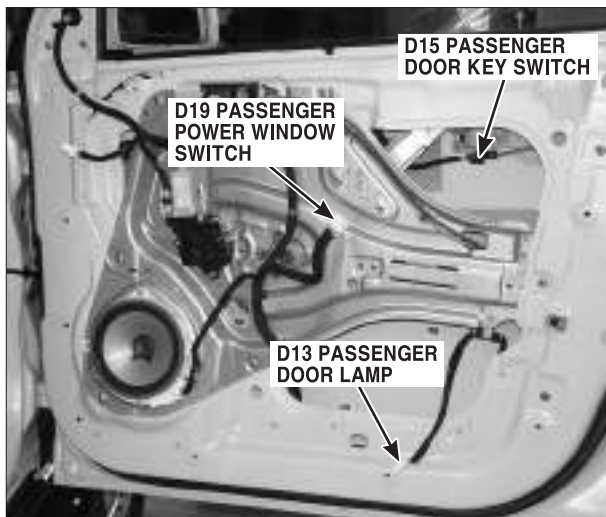

PHOTO.107

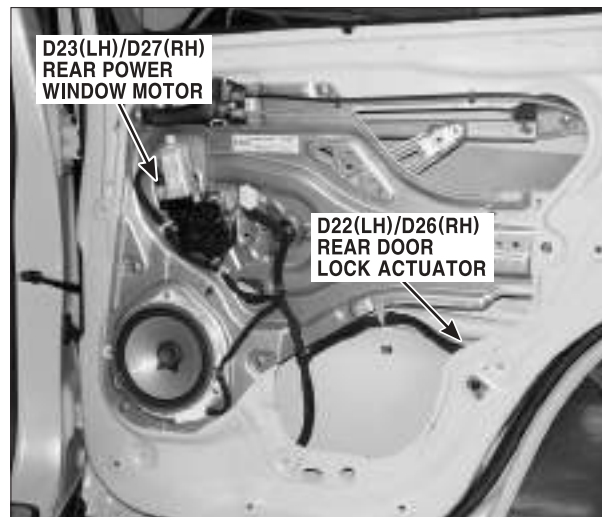
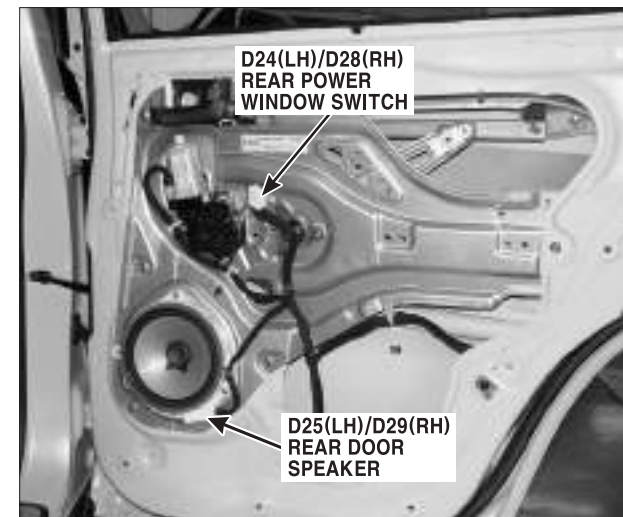

PHOTO.108



COMPONENT LOCATIONS

COMPONENT LOCATIONS (19)

CL-19

PHOTO.109

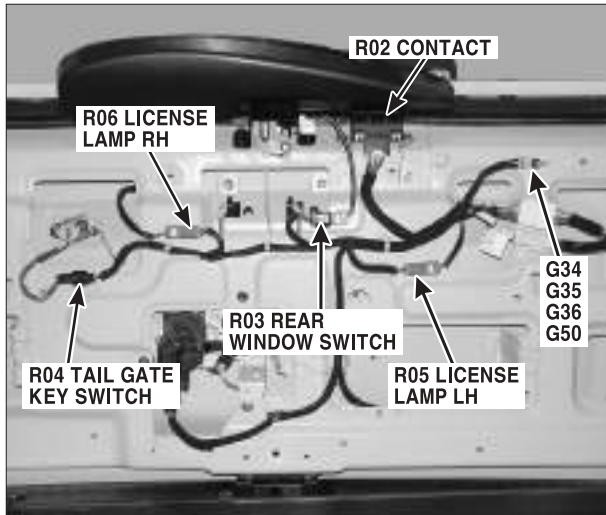

PHOTO.110

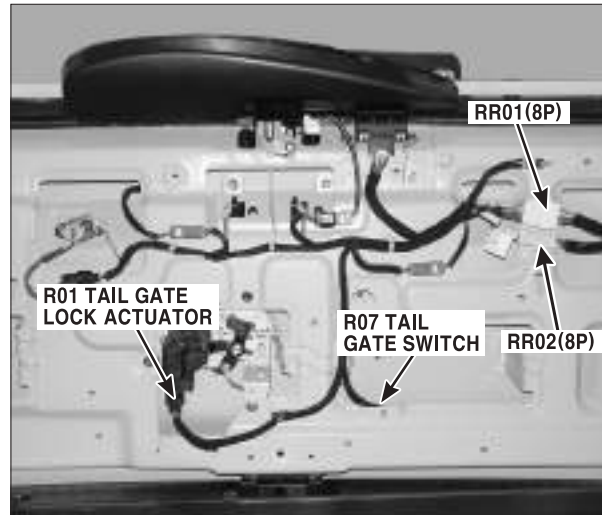

PHOTO.111



PHOTO.112

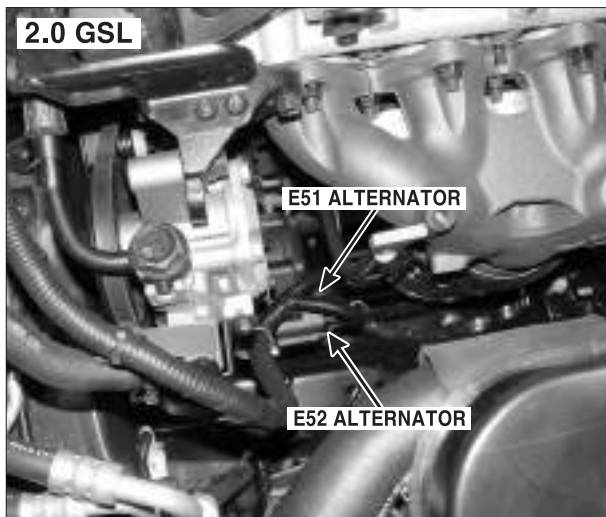

PHOTO.113

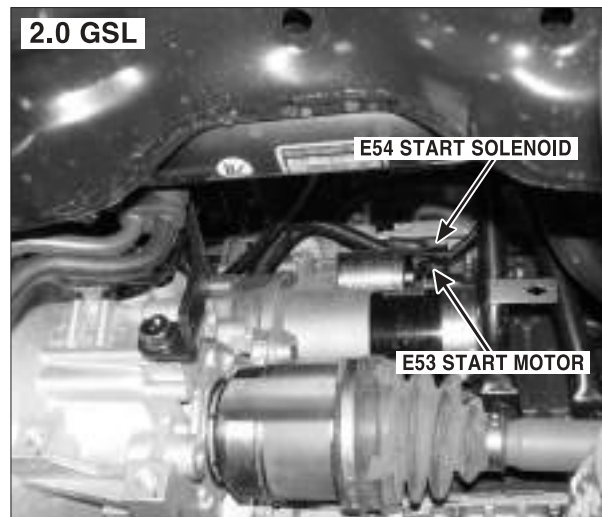
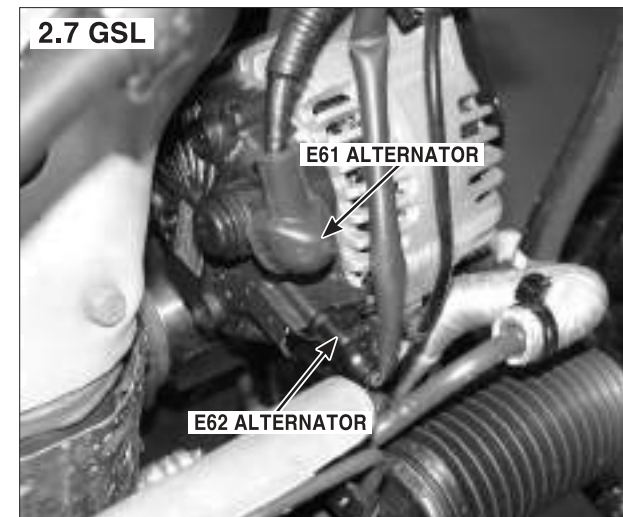

PHOTO.114



COMPONENT LOCATIONS

COMPONENT LOCATIONS (20)

CL-20

PHOTO.115



PHOTO.116

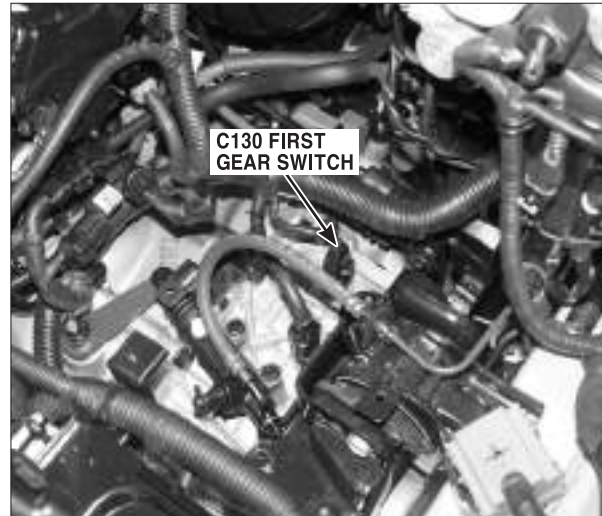

PHOTO.117

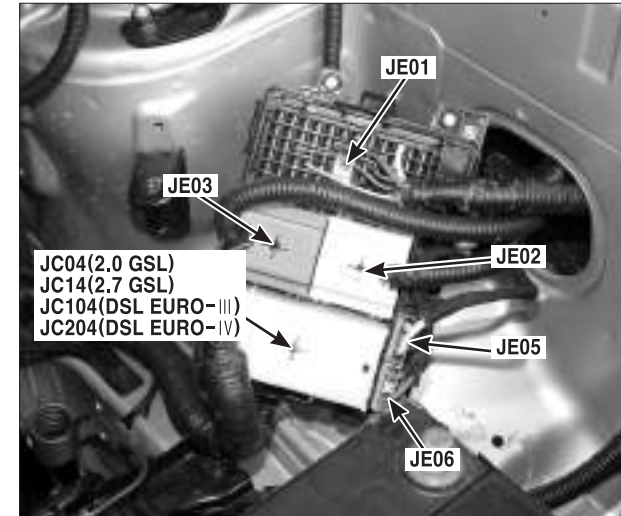

PHOTO.118



PHOTO.119

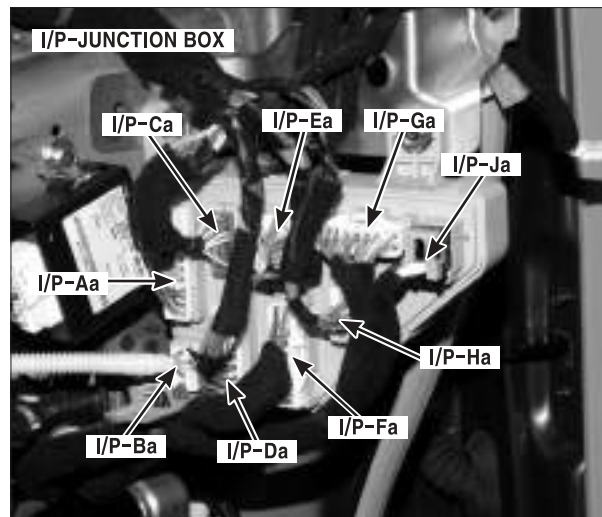
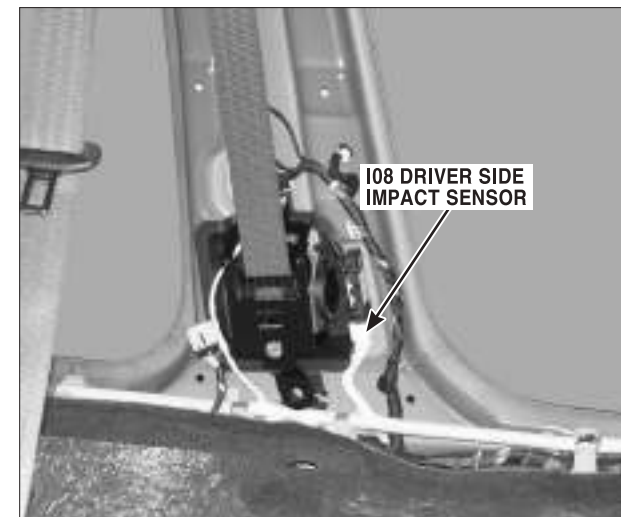

PHOTO.120



COMPONENT LOCATIONS

COMPONENT LOCATIONS (21)

CL-21

PHOTO.121

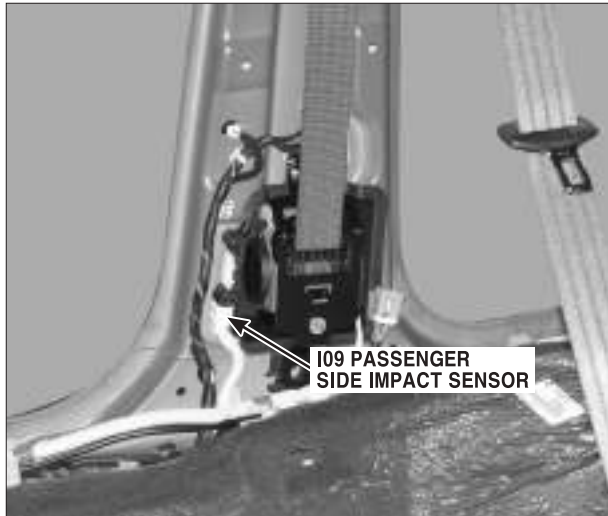

PHOTO.122

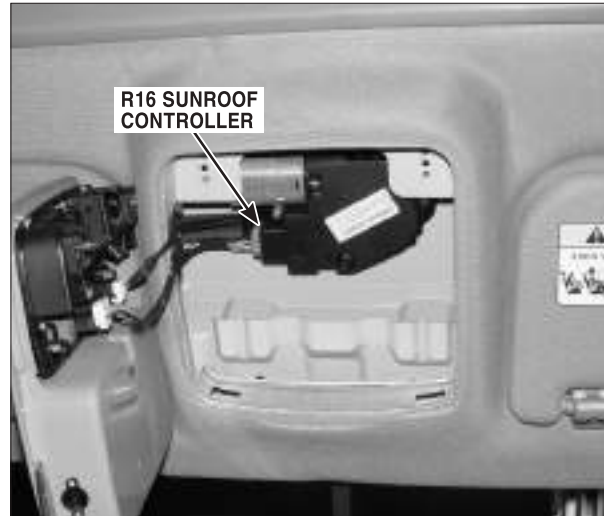

PHOTO.123

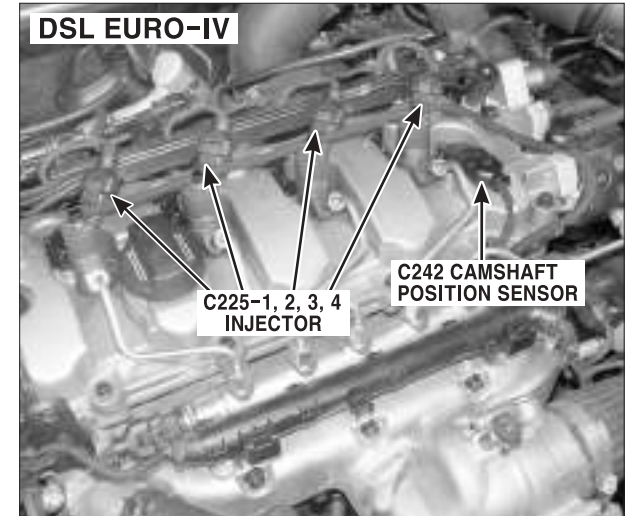

PHOTO.124

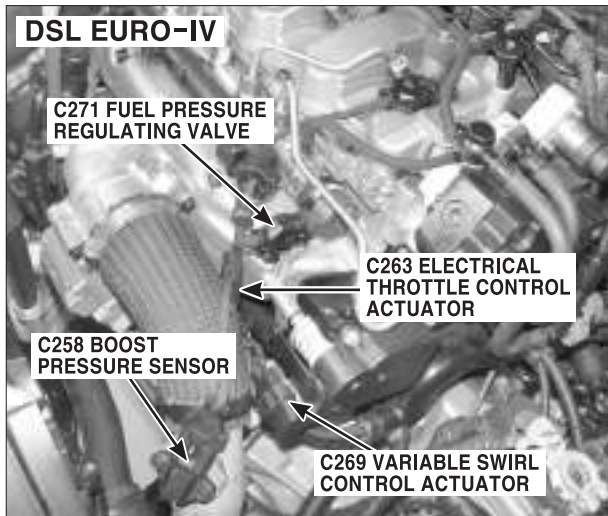

PHOTO.125

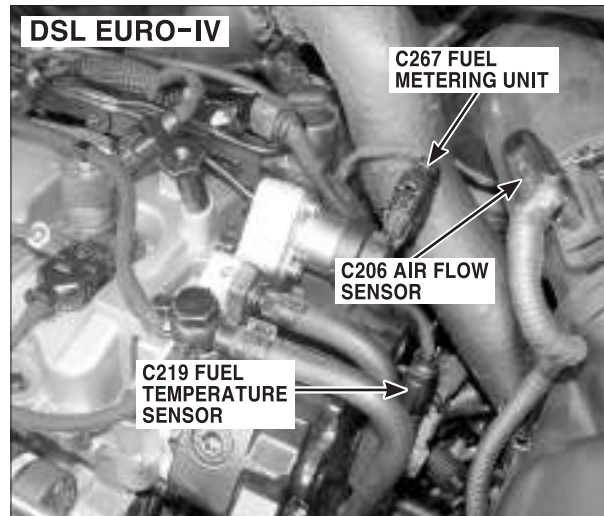
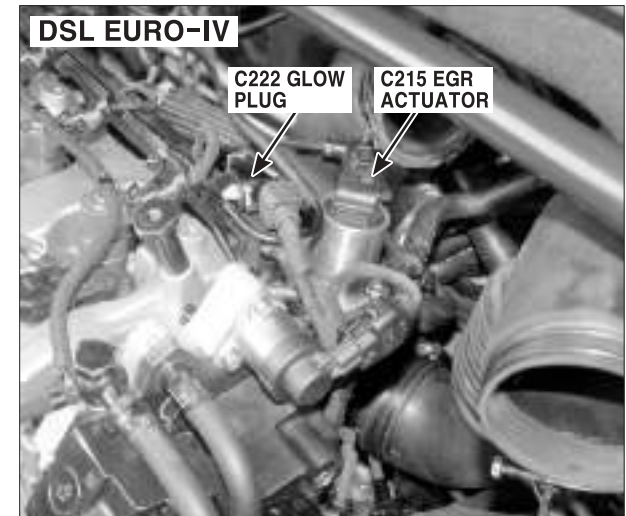

PHOTO.126



COMPONENT LOCATIONS

COMPONENT LOCATIONS (22)

CL-22

PHOTO.127

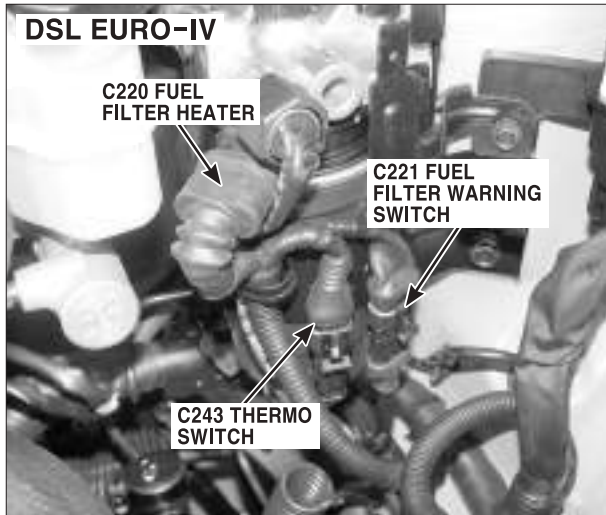

PHOTO.128

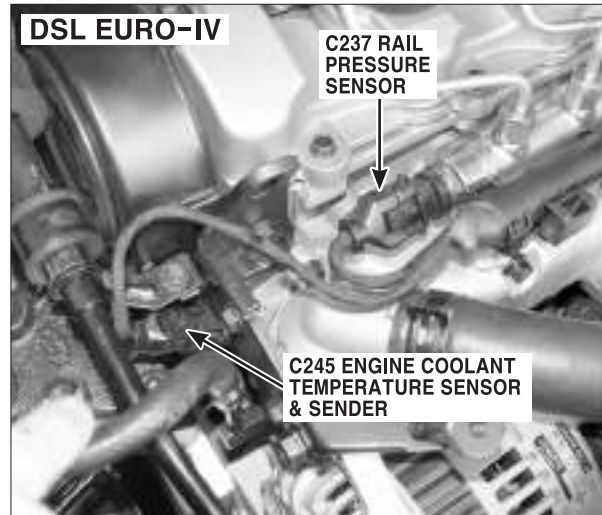

PHOTO.129

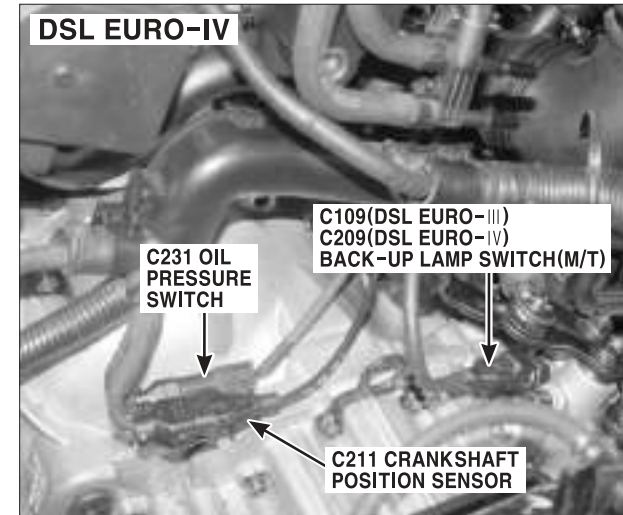
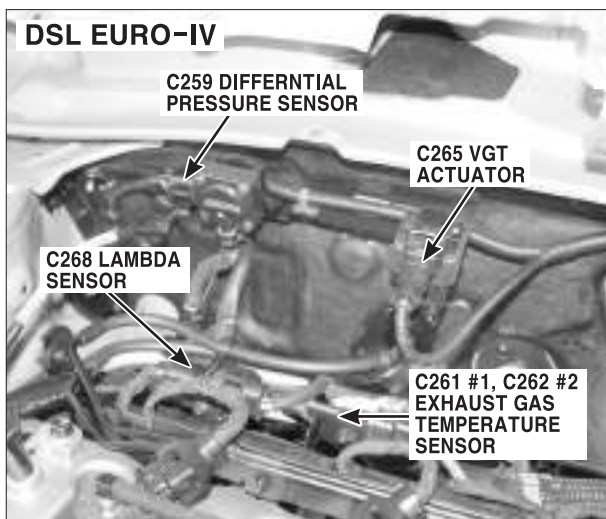

PHOTO.130



HARNESS CONNECTORS

EFF55190

HARNESS CONNECTORS (1)

CC-1

CF01/CF11/CF101/CF201

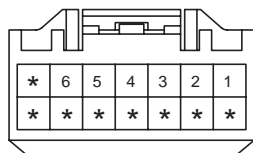

AMP_090III_14F_W

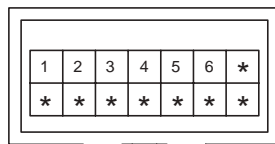

AMP_090III_14M_W

EC01/EC11

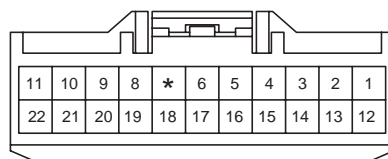

AMP_090III_22F_W

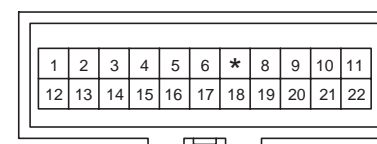

AMP_090III_22M_W

EC101

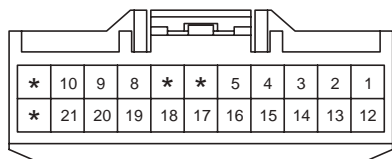

AMP_090III_22F_W

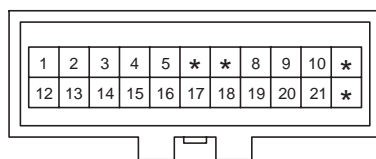

AMP_090III_22M_W

EC201

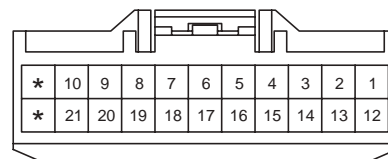

AMP_090III_22F_W

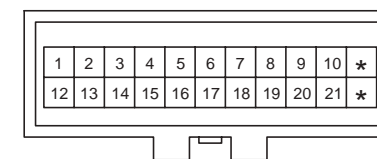

AMP_090III_22M_W

EE01/EE11

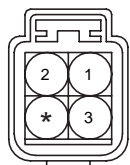

KUM_NMWP_04F_B

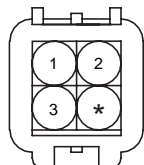

KUM_NMWP_04M_B

EE02

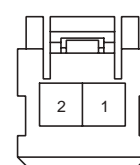

AMP_090III_02F_B

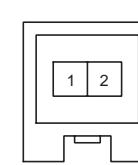

AMP_090III_02M_B

EE101/EE201

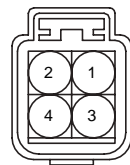

KUM_NMWP_04F_B

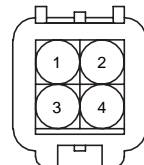

KUM_NMWP_04M_B

EF01

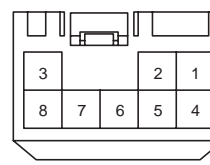

AMP_090III_08F_W

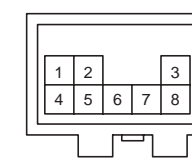

AMP_090III_08M_W

EI01

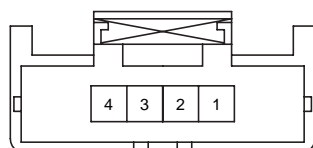

AMP_MQS_4F_Y

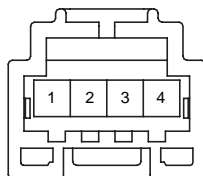

AMP_MQS_4M_Y

EM01

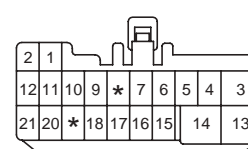

KET_1809_21F_W_A

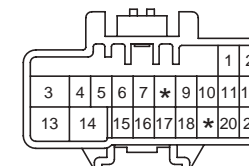

KET_1809_21M_W_A

HARNES CONNECTORS

HARNES CONNECTORS (2)

CC-2

EM02

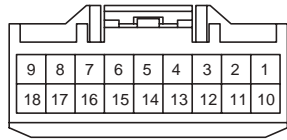

AMP_090III_18F_W

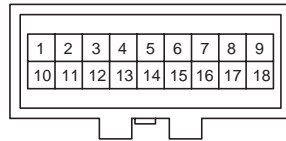

AMP_090III_18M_W

BLANK

FD01

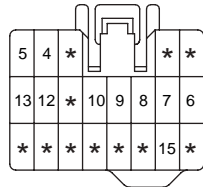
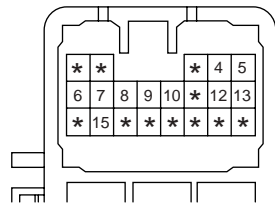

KET_050_21F_B

FD03

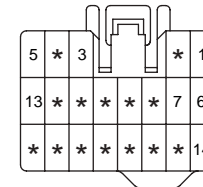
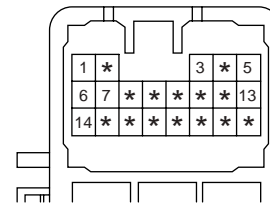

KET_050_21F_B

FD02

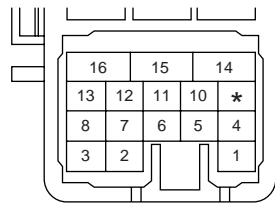

KET_180905_37M_W

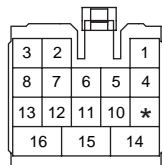

KET_1809_16F_W

FD04

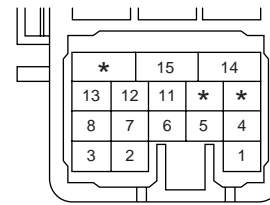

KET_180905_37M_W

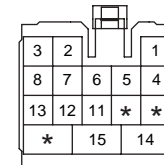

KET_1809_16F_W

FD05

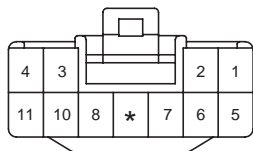

KET_090II_11F_W

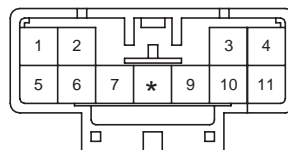

KET_090II_11M_W

FD06

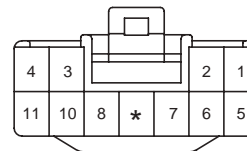

KET_090II_11F_W

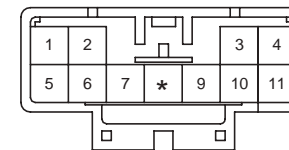

KET_090II_11M_W

FR01

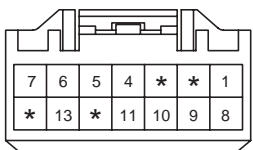

AMP_090III_14F_W

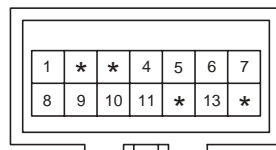

AMP_090III_14M_W

FR02

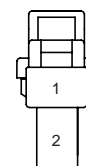

KET_250DL_02F_W

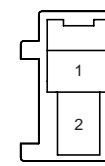

KET_250DL_02M_W

HARNESS CONNECTORS

HARNESS CONNECTORS (3)

CC-3

MC01

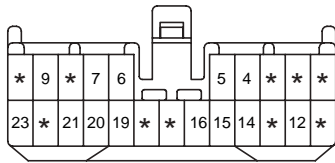

KET_050_23F_W

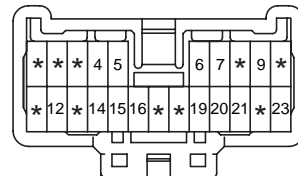

KET_050_23M_W

MC11

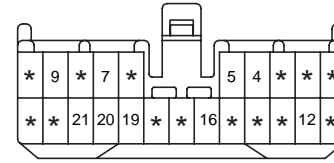

KET_050_23F_W

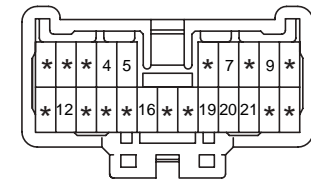

KET_050_23M_W

MC101

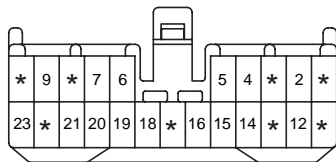

KET_050_23F_W

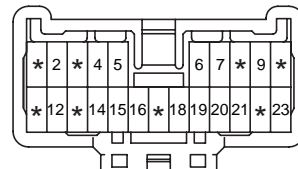

KET_050_23M_W

MC201

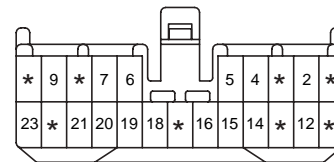

KET_050_23F_W

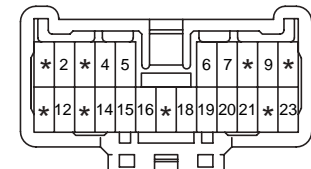

KET_050_23M_W

MC02

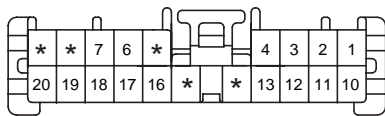

KET_070II_20F_W

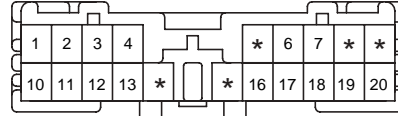

KET_070II_20M_W

MC12

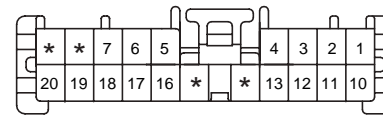

KET_070II_20F_W

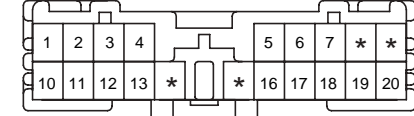

KET_070II_20M_W

MC102

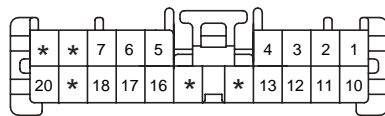

KET_070II_20F_W

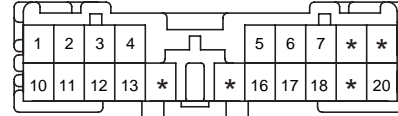

KET_070II_20M_W

MC202

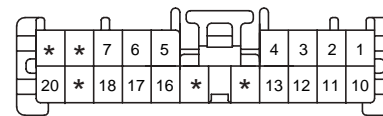

KET_070II_20F_W

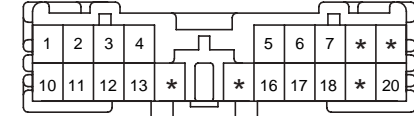

KET_070II_20M_W

MC03

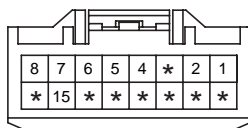

KET_090III_16F_L

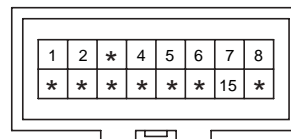

KET_090III_16M_L

MC13

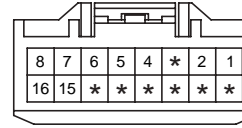

KET_090III_16F_L

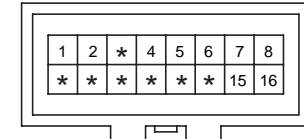

KET_090III_16M_L

HARNESS CONNECTORS

HARNESS CONNECTORS (4)

CC-4

MC103

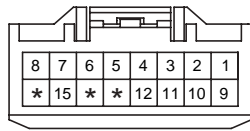

KET_090III_16F_L

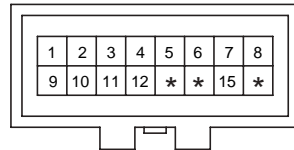

KET_090III_16M_L

MC203

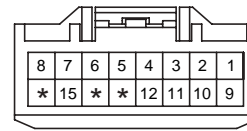

KET_090III_16F_L

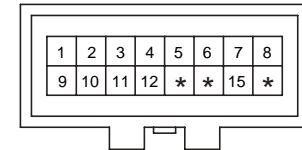

KET_090III_16M_L

MC04/MC14/MC104/MC204

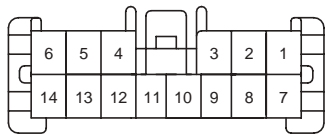

KET_070II_14F_Y

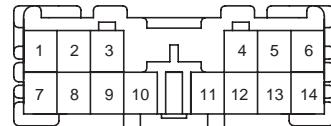

KET_070II_14M_Y

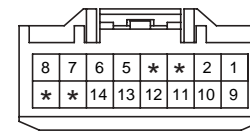

KET_090III_16F_L

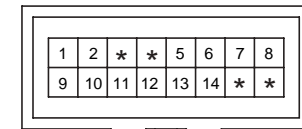

KET_090III_16M_L

MF02

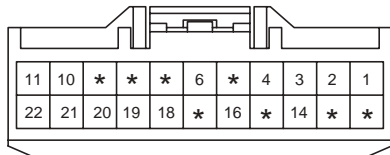

AMP_090III_22F_W

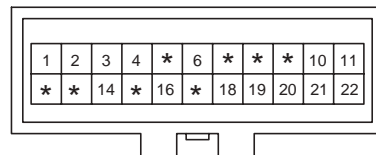

AMP_090III_22M_W

MF03

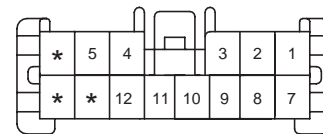

KET_070II_14F_Y

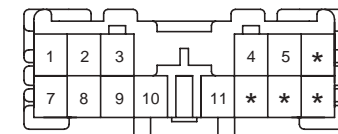

KET_070II_14M_Y

MI01

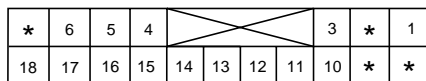

KUM_2504_18F_B

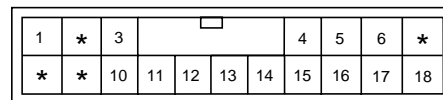

KUM HY031-18027

MI02

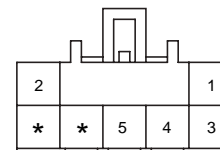

KUM_CDR_07F_B

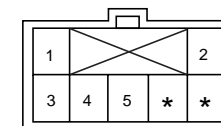

KUM PH841-07020

MI03



KUM_2504_18F_B

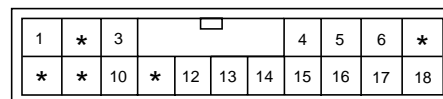

KUM HY031-18027

MI04

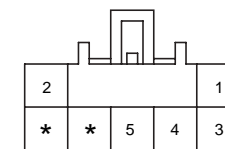

KUM_CDR_07F_B

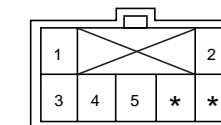

KUM PH841-07020

HARNES CONNECTORS

HARNES CONNECTORS (5)

CC-5

MI05

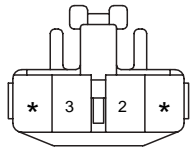

KET_090II_04F_W

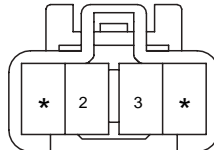

KET_090II_04M_W

MR02

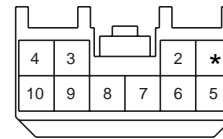

AMP_090III_10F_W

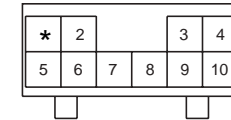

AMP_090III_10M_W

RR01

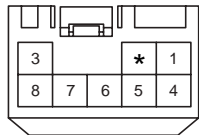

AMP_090III_08F_W

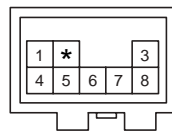

AMP_090III_08M_W

RR02

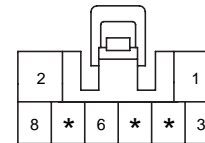

KET_2507_08F_W

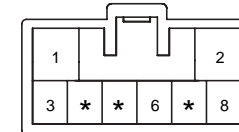

KET_2507_08M_W

RR03

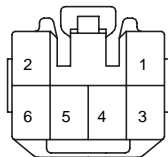

KET_090II_06F_W

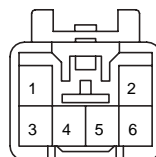

KET_090II_06M_W

BLANK

E/R & I/P JUNCTION BOX (1)			CC-6
<p style="text-align: center;">I/P-A</p> <p style="text-align: right;">AMP_0925_20F_W</p>	<p style="text-align: center;">I/P-B</p> <p style="text-align: right;">AMP_090III_08F_W</p>	<p style="text-align: center;">I/P-C</p> <p style="text-align: right;">AMP_040III_20F_Br</p>	
<p style="text-align: center;">I/P-D</p> <p style="text-align: right;">AMP_0925_16F_W</p>	<p style="text-align: center;">I/P-E</p> <p style="text-align: right;">AMP_090III_14F_W</p>	<p style="text-align: center;">I/P-F</p> <p style="text-align: right;">AMP_0925_18F_W</p>	
<p style="text-align: center;">I/P-G</p> <p style="text-align: right;">AMP_0925_14F_W</p>	<p style="text-align: center;">I/P-H</p> <p style="text-align: right;">AMP_090III_10F_W</p>	<p style="text-align: center;">I/P-J</p> <p style="text-align: right;">KET_58L_02F_W</p>	
<p style="text-align: center;">I/P-AR</p> <p style="text-align: right;">AMP_0925_20F_W</p>	<p style="text-align: center;">I/P-BR</p> <p style="text-align: right;">AMP_090III_08F_W</p>	<p style="text-align: center;">I/P-CR</p> <p style="text-align: right;">AMP_040III_20F_Br</p>	
<p style="text-align: center;">I/P-DR</p> <p style="text-align: right;">AMP_0925_16F_W</p>	<p style="text-align: center;">I/P-ER</p> <p style="text-align: right;">AMP_090III_14F_W</p>	<p style="text-align: center;">I/P-FR</p> <p style="text-align: right;">AMP_0925_18F_W</p>	

E/R & I/P JUNCTION BOX

E/R & I/P JUNCTION BOX (2)

CC-7

I/P-GR

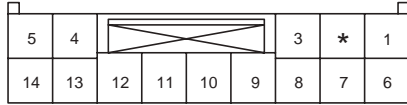

AMP_0925_14F_W

I/P-HR

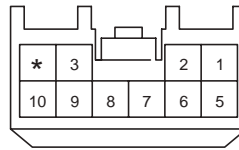

AMP_090III_10F_W

I/P-JR

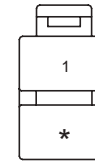

KET_58L_02F_W

JC04

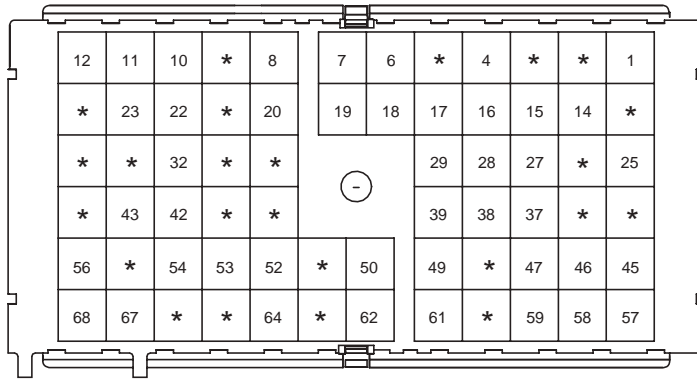

PKD_280_68F_N_104

JC14

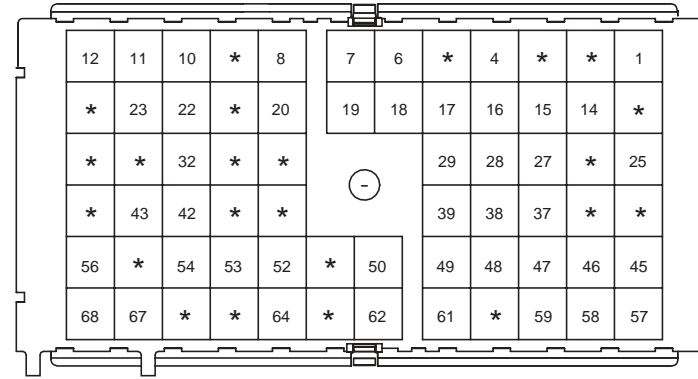

PKD_280_68F_N_104

JC104

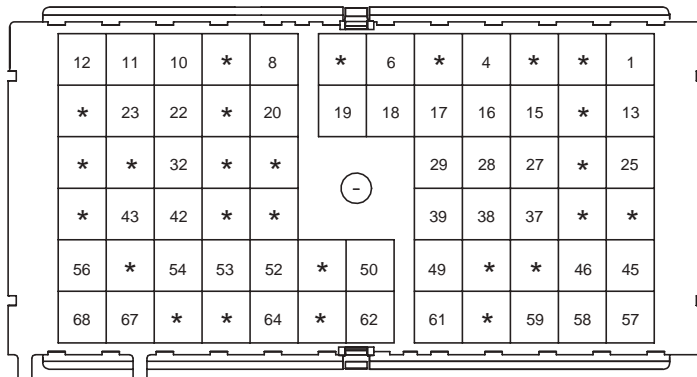

PKD_280_68F_N_104

JC204

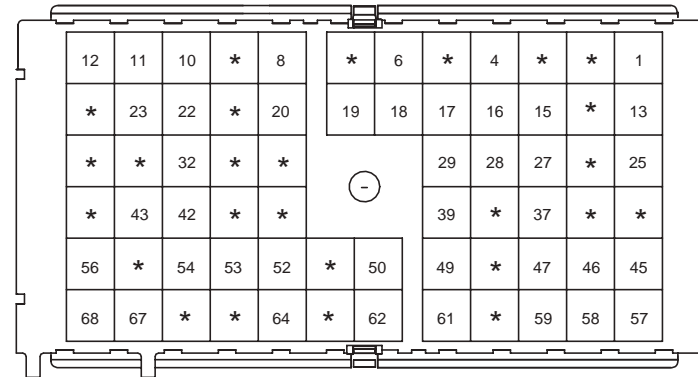

PKD_280_68F_N_104

E/R & I/P JUNCTION BOX

E/R & I/P JUNCTION BOX (3)

CC-8

JE01

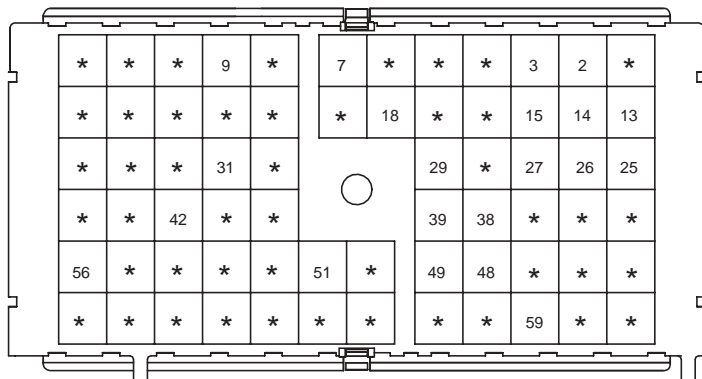

PKD_280_68F_B_102

JE02

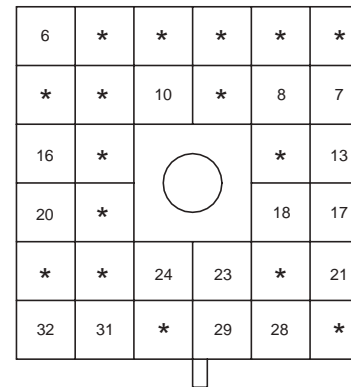

PKD_280_32F_N_101

JE03

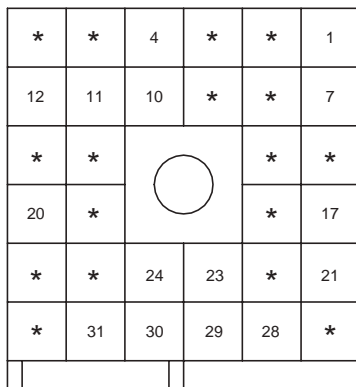

PKD_280_32F_GR_102

JE05

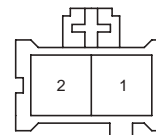

PKD_800_02F_GR_104

JE06

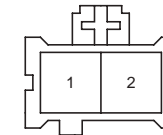

PKD_800_02F_G_102

BLANK

JOINT CONNECTORS (1)		CC-9
<p>C24</p> <p>KET_090II_20F_B_JCH</p>	<p>C25</p> <p>KET_090II_20F_B_JCH</p>	<p>C26</p> <p>KET_070_08F_JCH</p>
<p>C73</p> <p>KET_090II_20F_B_JCH</p>	<p>C74</p> <p>KET_090II_20F_B_JCH</p>	<p>C75</p> <p>KET_070_08F_JCH</p>
<p>C76</p> <p>KET_070_08F_JCH</p>	<p>C126</p> <p>KET_090II_20F_B_JCH</p>	<p>C127</p> <p>KET_090II_20F_B_JCH</p>
<p>C128</p> <p>KET_070_08F_JCH</p>	<p>C129</p> <p>KET_090II_08F_W</p>	<p>C148</p> <p>KET_070_08F_JCH</p>
<p>C226</p> <p>KET_090II_20F_B_JCH</p>	<p>C227</p> <p>KET_090II_20F_B_JCH</p>	<p>C228</p> <p>KET_070_08F_JCH</p>

JOINT CONNECTORS

JOINT CONNECTORS (2)

CC-10

C248

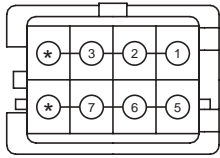

KET_070_08F_JCH

D03

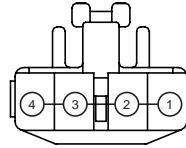

KET_090II_04F_W

F20

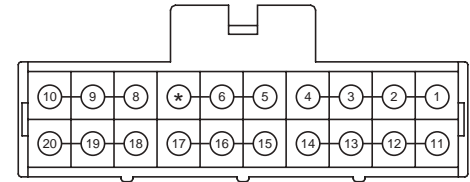

KET_090II_20F_B_JCH

F21

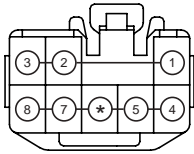

KET_090II_08F_W

F22

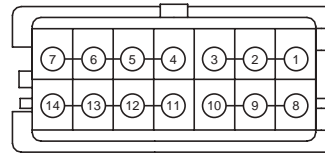

KET_070_14F_B_JCH

M16

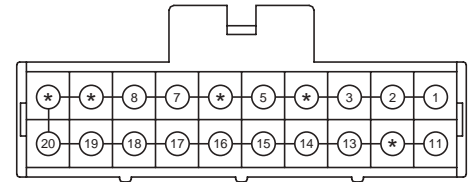

KET_090II_20F_B_JCH

M17

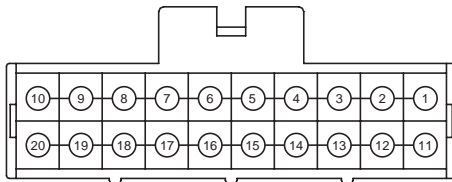

KET_090II_20F_B_JCH

M18

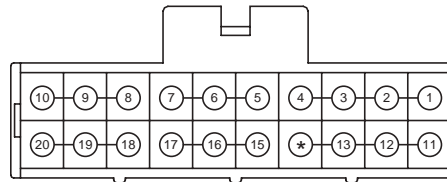

KET_090II_20F_B_JCH

M19

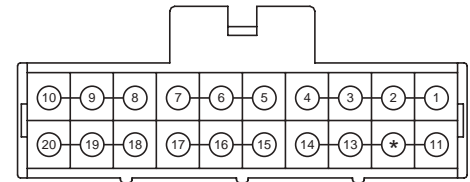

KET_090II_20F_B_JCH

M40

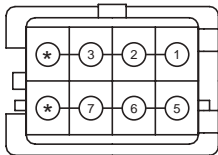

KET_070_08F_W_JCH

BLANK

BLANK

MAIN HARNESS (1)

HL-1

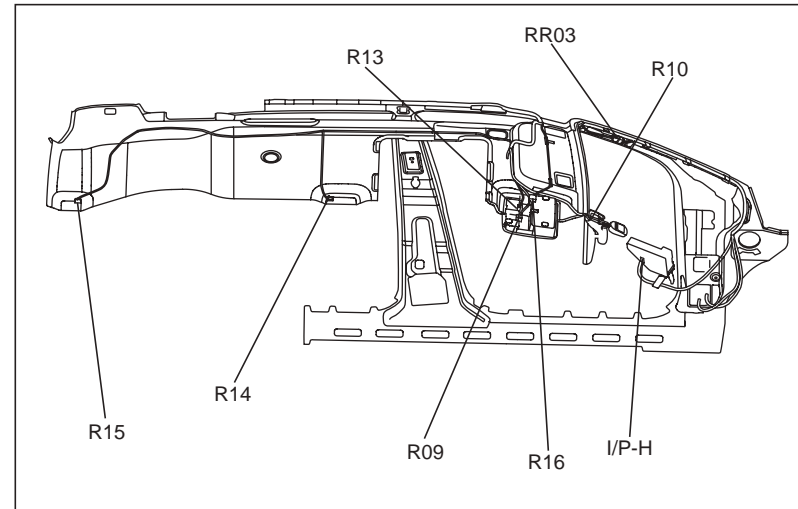
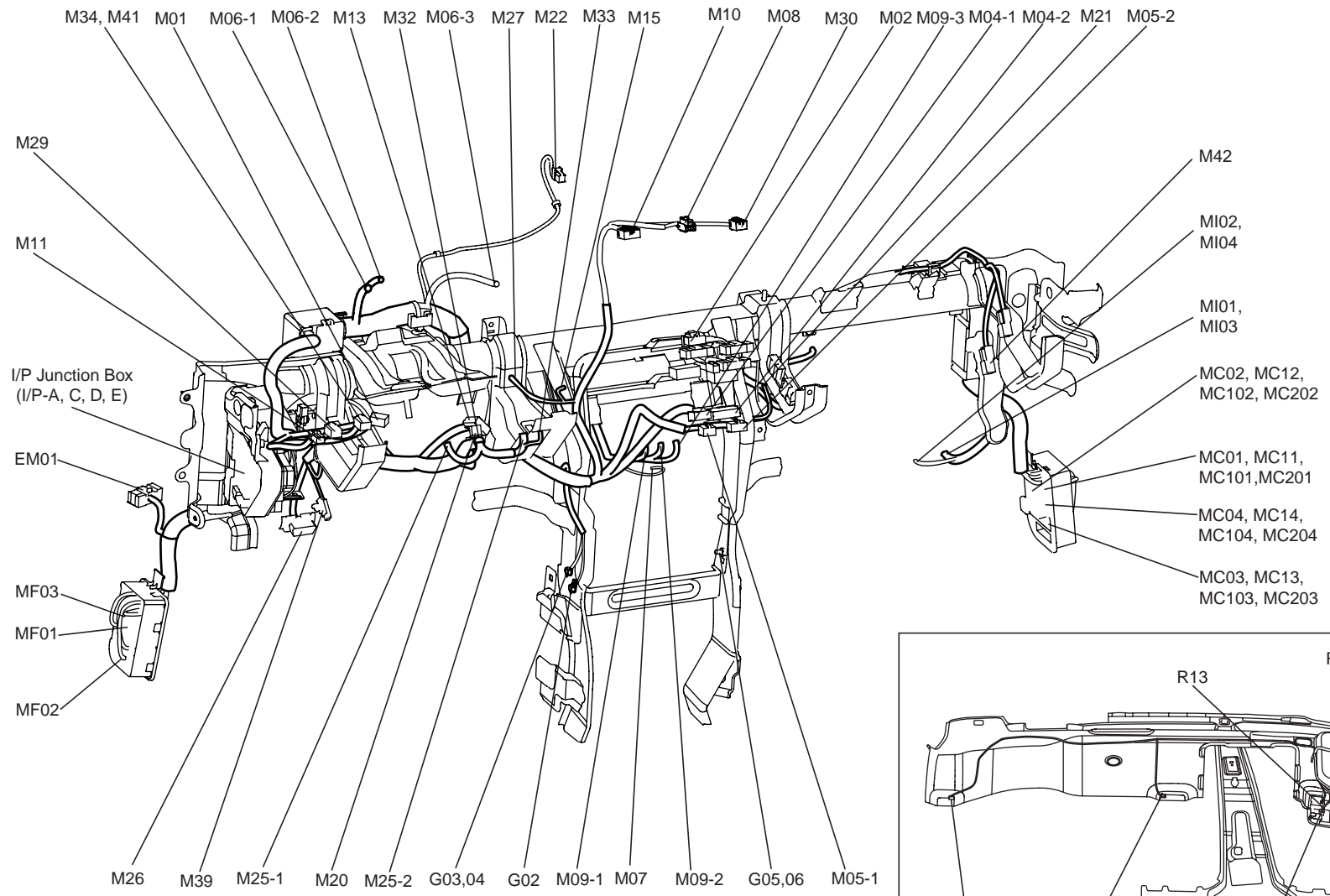

MAIN HARNESS

MAIN HARNESS (2)

HL-2

MAIN HARNESS

M01	4WD Lock Switch	EM01	Connection With ENGINE Harness RH
M02	Audio	EM02	Connection With ENGINE Harness RH
M04-1	A/C Control Module (Auto)	I/P-A	Connection With I/P JUNCTION BOX Harness (LHD)
M04-2	A/C Control Module (Auto)	I/P-AR	Connection With I/P JUNCTION BOX Harness (RHD)
M05-1	A/C Control Module (Manual)	I/P-C	Connection With I/P JUNCTION BOX Harness (LHD)
M05-2	A/C Control Module (Manual)	I/P-CR	Connection With I/P JUNCTION BOX Harness (RHD)
M06-1	Instrument Cluster	I/P-D	Connection With I/P JUNCTION BOX Harness (LHD)
M06-2	Instrument Cluster	I/P-DR	Connection With I/P JUNCTION BOX Harness (RHD)
M06-3	Instrument Cluster	I/P-E	Connection With I/P JUNCTION BOX Harness (LHD)
M07	Cigarette Lighter	I/P-ER	Connection With I/P JUNCTION BOX Harness (RHD)
M08	Digital Clock	I/P-HR	Connection With I/P JUNCTION BOX Harness (RHD)
M09-1	ETACM	MC01	Connection With CONTROL Harness (2.0 GSL)
M09-2	ETACM	MC02	Connection With CONTROL Harness (2.0 GSL)
M09-3	ETACM	MC03	Connection With CONTROL Harness (2.0 GSL)
M10	Hazard Switch	MC04	Connection With CONTROL Harness (2.0 GSL)
M11	Head Lamp Leveling Switch	MC11	Connection With CONTROL Harness (2.7 GSL)
M13	Ignition Switch	MC12	Connection With CONTROL Harness (2.7 GSL)
M14	SMATRA	MC13	Connection With CONTROL Harness (2.7 GSL)
M14-1	Immobilizer Control Module	MC14	Connection With CONTROL Harness (2.7 GSL)
M14-2	Immobilizer Control Module	MC101	Connection With CONTROL Harness (DSL EURO-III)
M15	Incar & Humidity Sensor	MC102	Connection With CONTROL Harness (DSL EURO-III)
M16	Joint Connector	MC103	Connection With CONTROL Harness (DSL EURO-III)
M17	Joint Connector	MC104	Connection With CONTROL Harness (DSL EURO-III)
M18	Joint Connector	MC201	Connection With CONTROL Harness (DSL EURO-IV)
M19	Joint Connector	MC202	Connection With CONTROL Harness (DSL EURO-IV)
M20	Key Remind Switch	MC203	Connection With CONTROL Harness (DSL EURO-IV)
M21	Flasher Unit	MC204	Connection With CONTROL Harness (DSL EURO-IV)
M22	Auto Light & Photo Sensor	MF01	Connection With FLOOR Harness
M25-1	Multifunction Switch (LHD)	MF02	Connection With FLOOR Harness
M25-1R	Multifunction Switch (RHD)	MF03	Connection With FLOOR Harness
M25-2	Multifunction Switch (LHD)	MI01	Connection With A/C Harness (Auto A/C)
M25-2R	Multifunction Switch (RHD)	MI02	Connection With A/C Harness (Auto A/C)
M26	Data Link Connector	MI03	Connection With A/C Harness (Manual A/C)
M27	Mode Switch	MI04	Connection With A/C Harness (Manual A/C)
M29	Rheostat	MI05	Connection With A/BAG Harness
M30	Rear Fog Lamp Switch	MR02	Connection With ROOF Harness (RHD)
M32	Multifunction Switch	G01	Ground
M33	Steering Angle Sensor	G02	Ground
M34	TCS Switch	G03	Ground
M37-1	ICM Box	G04	Ground
M37-2	CM Box	G05	Ground
M39	Vertical Resistor	G06	Ground
M40	Joint Connector		
M41	ESP Switch		
M42	Glove Box Lamp		
Z01	PRE - Excitation Resistor		

ROOF HARNESS

R09	Sunroof Switch
R10	Electro Chrome Mirror (ECM)
R13	MAP Lamp
R14	Room Lamp
R15	Cargo Lamp
R26	Vanity Lamp LH
R27	Vanity Lamp RH
I/P-H	Connection With I/P JUNCTION BOX Harness (LHD)
MR02	Connection With MAIN Harness (RHD)
RR03	Connection With S/ROOF Harness

SUNROOF HARNESS

R16	Sunroof Controller
RR03	Connection With ROOF Harness

ENGINE HARNESS (1)

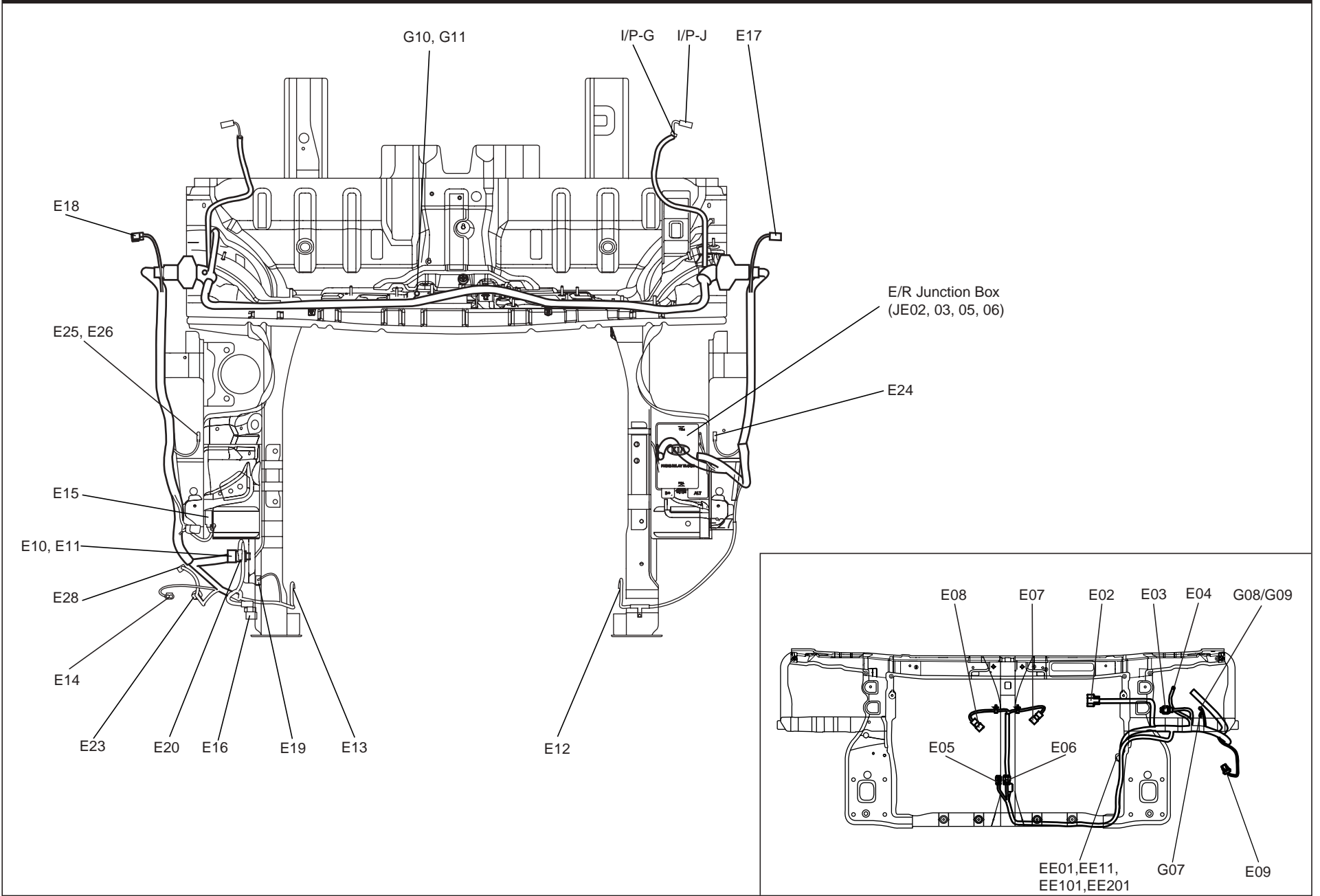

ENGINE HARNESS

ENGINE HARNESS (2)

HL-4

ENGINE HARNESS RH

E10	ABS Control Module
E11	ESP Control Module
E12	Driver Impact Sensor
E13	Assistor Impact Sensor
E14	Front Fog Lamp RH
E15	Hood Switch
E16	Head Lamp RH
E17	Side Repeater Lamp LH
E18	Side Repeater Lamp RH
E19	Triple Switch
E20	Head Lamp Leveling Actuator RH
E23	Washer Motor
E24	Front Wheel Sensor LH
E25	Front Wheel Sensor RH (4WD)
E26	Front Wheel Sensor RH
E28	Washer Level Switch
E31	Air Pressusr Transducer (DSL EURO-IV)
EC01	Connection With CONTROL Harness (2.0 GSL)
EC11	Connection With CONTROL Harness (2.7 GSL)
EC101	Connection With CONTROL Harness (DSL EURO-III)
EC201	Connection With CONTROL Harness (DSL EURO-IV)
EF01	Connection With FLOOR Harness
EI01	Connection With A/BAG Harness
EM01	Connection With MAIN Harness
EM02	Connection With MAIN Harness
I/P-G	Connection With I/P JUNCTION BOX Harness (LHD)
I/P-GR	Connection With I/P JUNCTION BOX Harness (RHD)
I/P-J	Connection With I/P JUNCTION BOX Harness (LHD)
I/P-JR	Connection With I/P JUNCTION BOX Harness (RHD)
JE02	Connection With E/R JUNCTION BOX Harness
JE03	Connection With E/R JUNCTION BOX Harness
JE05	Connection With E/R JUNCTION BOX Harness
JE06	Connection With E/R JUNCTION BOX Harness
G10	Ground
G11	Ground
G12	Ground
G13	Ground
G14	Ground
G15	Ground

ENGINE HARNESS LH

E02	Cooling Fan Motor
E03	Head Lamp LH
E04	Head Lamp Leveling Actuator LH
E05	Ambient Sensor
E06	AQS Sensor
E07	Horn LH
E08	Horn RH
E09	Front Fog Lamp LH
EE01	Connection With BATTERY Harness (2.0 GSL)
EE11	Connection With BATTERY Harness (2.7 GSL)
EE101	Connection With BATTERY Harness (DSL EURO-III)
EE201	Connection With BATTERY Harness (DSL EURO-IV)
JE01	Connection With E/R JUNCTION BOX Harness
G07	Ground
G08	Ground
G09	Ground

BATTERY HARNESS

E51	Alternator (2.0 GSL)
E52	Alternator (2.0 GSL)
E53	Start Motor (2.0 GSL)
E54	Start Solenoid (2.0 GSL)
E61	Alternator (2.7 GSL)
E62	Alternator (2.7 GSL)
E63	Start Motor (2.7 GSL)
E64	Start Solenoid (2.7 GSL)
E104	A/C Compressor (DSL EURO-III)
E151	Alternator (DSL EURO-III)
E152	Alternator (DSL EURO-III)
E153	Start Motor (DSL EURO-III)
E154	Start Solenoid (DSL EURO-III)
E204	A/C Compressor (DSL EURO-IV)
E251	Alternator (DSL EURO-IV)
E252	Alternator (DSL EURO-IV)
E253	Start Motor (DSL EURO-IV)
E254	Start Solenoid (DSL EURO-IV)
EE01	Connection With ENGINE LH Harness (2.0 GSL)
EE11	Connection With ENGINE LH Harness (2.7 GSL)
EE101	Connection With ENGINE LH Harness (DSL EURO-III)
EE201	Connection With ENGINE LH Harness (DSL EURO-IV)

FLOOR HARNESS (1)

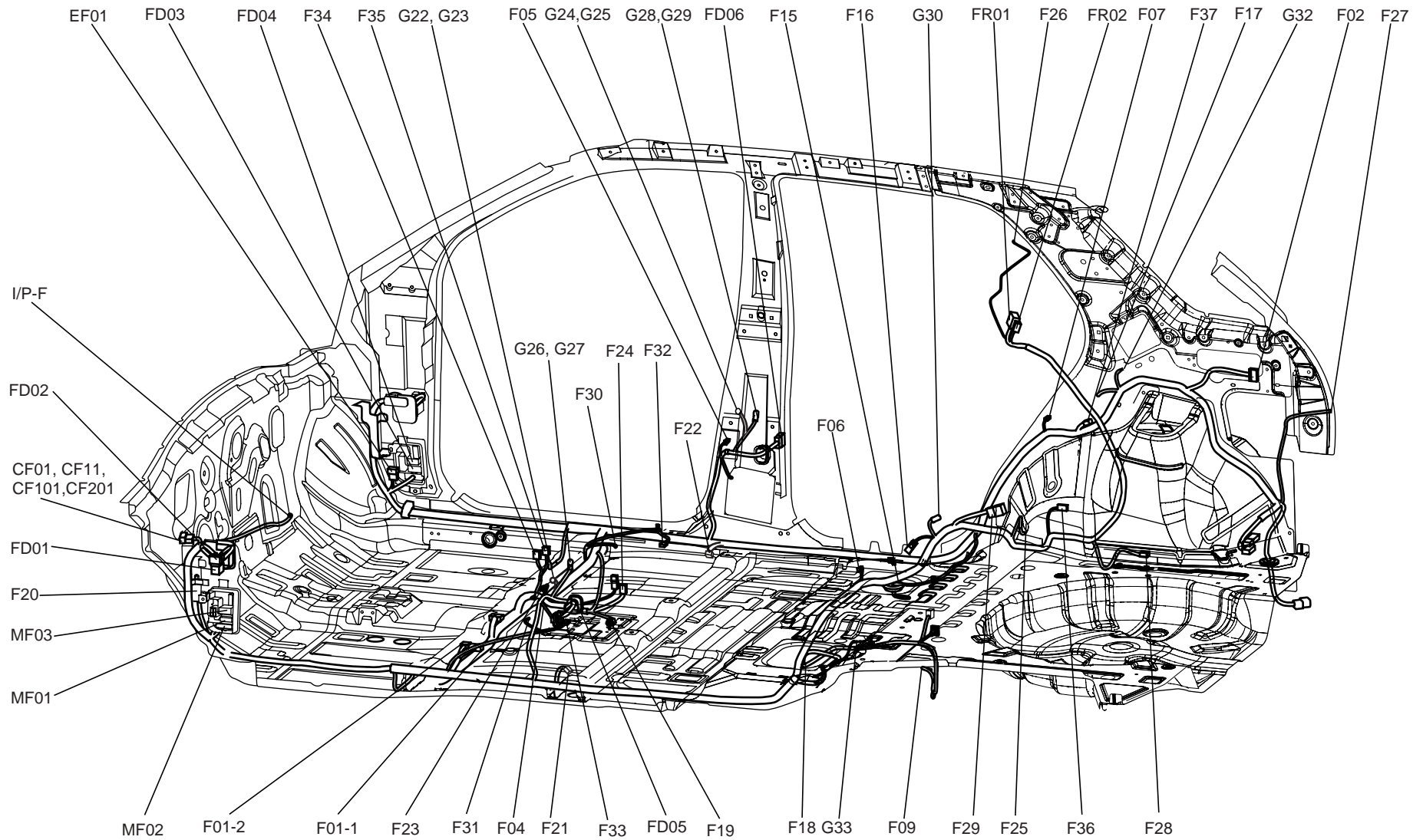

FLOOR HARNESS

FLOOR HARNESS (2)

HL-6

FLOOR HARNESS

F01-1	AMP #1	F36	Luggage Lamp
F01-2	AMP #2	F37	Joint Connector
F04	Front Door Switch LH	CF01	Connection With CONTROL Harness (2.0 GSL)
F05	Front Door Switch RH	CF11	Connection With CONTROL Harness (2.7 GSL)
F06	Rear Door Switch LH	CF101	Connection With CONTROL Harness (DSL EURO-III)
F07	Rear Door Switch RH	CF201	Connection With CONTROL Harness (DSL EURO-IV)
F09	Electronic Magnetic Valve Clutch	EF01	Connection With ENGINE RH Harness
F15	Sub Sender	FD01	Connection With DRIVER DOOR Harness
F16	Rear Wheel Sensor LH	FD02	Connection With DRIVER DOOR Harness
F17	Rear Wheel Sensor RH	FD03	Connection With PASSENGER DOOR Harness
F18	Fuel Sender & Fuel Pump Motor	FD04	Connection With PASSENGER DOOR Harness
F19	G-SENSOR	FD05	Connection With REAR DOOR Harness LH
F20	Joint Connecetor	FD06	Connection With REAR DOOR Harness RH
F21	Joint Connecetor	FR01	Connection With TAIL GATE EXT. Harness
F22	Joint Connecetor	FR02	Connection With TAIL GATE EXT. Harness
F23	Parking Brake Switch	MF01	Connection With MAIN Harness
F24	Front Power Outlet	MF02	Connection With MAIN Harness
F25	Rear Power Outlet	MF03	Connection With MAIN Harness
F26	Roof Antenna	I/P-F	Connection With I/P JUNCTION BOX Harness (LHD)
F27	Rear Combi Lamp RH	I/P-FR	Connection With I/P JUNCTION BOX Harness (RHD)
F28	Rear Combi Lamp LH	G22	Ground
F29	Rear Wiper Relay	G23	Ground
F30	Sub Woofer	G24	Ground
F31	Driver Seat Belt Switch	G25	Ground
F32	Passenger Seat Warmer	G26	Ground
F33	Driver Seat Warmer	G27	Ground
F34	Passenger Seat Warmer Switch	G28	Ground
F35	Driver Seat Warmer Switch	G29	Ground
		G30	Ground
		G32	Ground
		G33	Ground

CONTROL HARNESS (1)

HL-7

2.0 GASOLINE

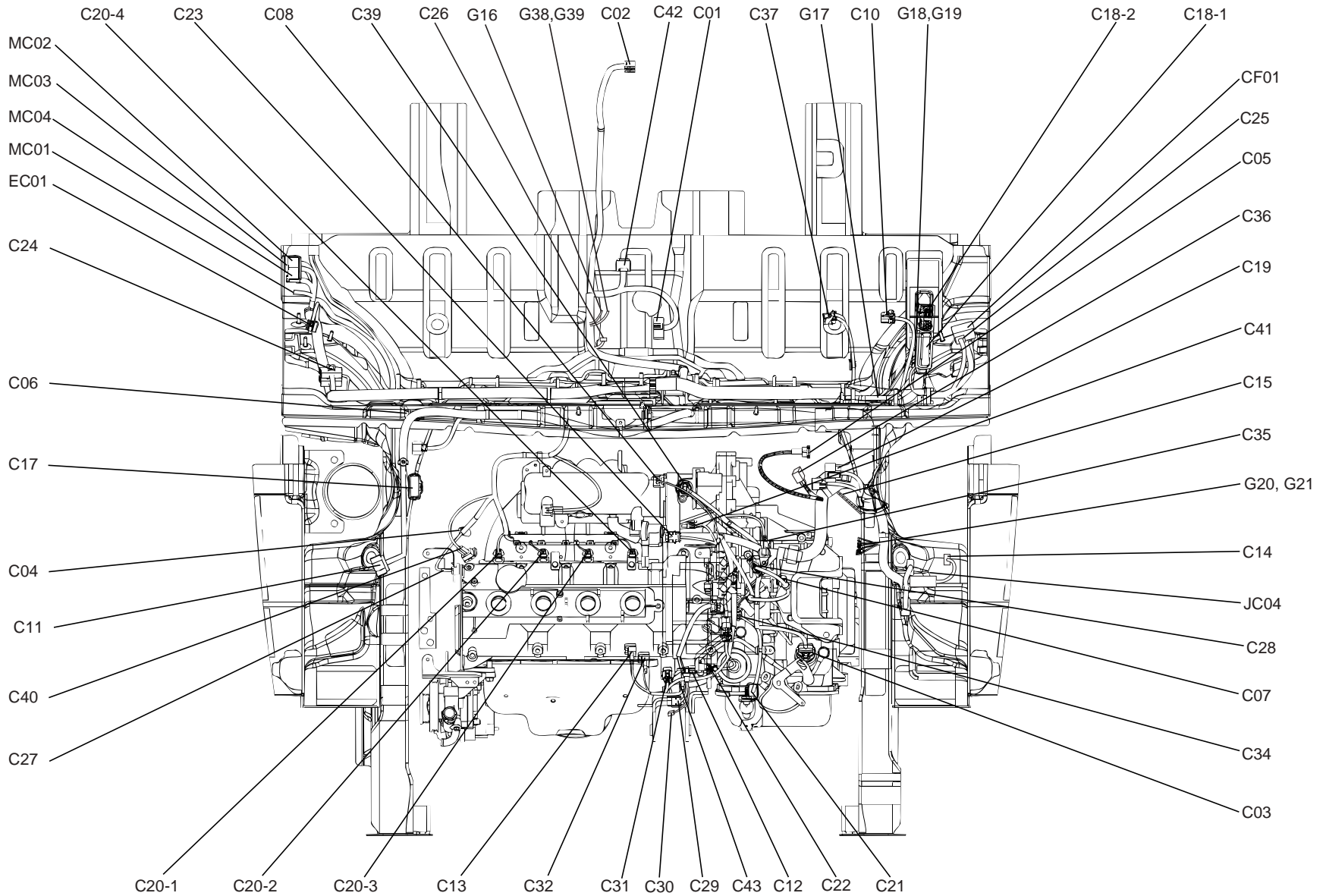

CONTROL HARNESS

CONTROL HARNESS (2)

HL-8

CONTROL HARNESS(2.0 GASOLINE)

C01	4WD ECM	C28	Mass Air Flow Sensor
C02	ATM Lever Switch	C29	Oxygen Sensor #1
C03	ATM Solenoid Valve	C30	Oxygen Sensor #2
C04	A/C Compressor	C31	Oil Pressure Switch
C05	Brake Fluid Level Sensor	C32	Oil Temperature Sensor
C06	Burglar Horn	C34	Pulse Generator 'A'
C07	Back-Up Lamp Switch	C35	Pulse Generator 'B'
C08	Canister Purge Control Valve	C36	Pressure Sensor
C10	Cruise Clutch Pedal Position Switch	C37	Stop Lamp Switch
C11	Cruise Control Module	C39	Vehicle Speed Sensor
C12	Crankshaft Position Sensor	C40	Camshaft Position Sensor
C13	CVVT Oil Control Valve	C41	Throttle Position Sensor
C14	Multipurpose Check Connector	C42	G-YAM Sensor
C15	Windshield Defogger	C43	Engine Coolant Temperature Sensor & Sender
C17	DRL Control Module	CF01	Connection With FLOOR Harness
C18-1	ECM	EC01	Connection With ENGINE Harness RH
C18-2	TCM	MC01	Connection With MAIN Harness
C19	Front Wiper Motor	MC02	Connection With MAIN Harness
C20-1	Injector #1	MC03	Connection With MAIN Harness
C20-2	Injector #2	MC04	Connection With MAIN Harness
C20-3	Injector #3	JC04	Connection With E/R JUNCTION BOX Harness
C20-4	Injector #4	G16	Ground
C21	Transaxle Range Switch	G17	Ground
C22	Ignition Coil	G18	Ground
C23	Idle Speed Control Actuator	G19	Ground
C24	Joint Connector	G20	Ground
C25	Joint Connector	G21	Ground
C26	Joint Connector	G38	Ground
C27	Knock Sensor	G39	Ground

CONTROL HARNESS

CONTROL HARNESS (3)

HL-9

2.7 GASOLINE

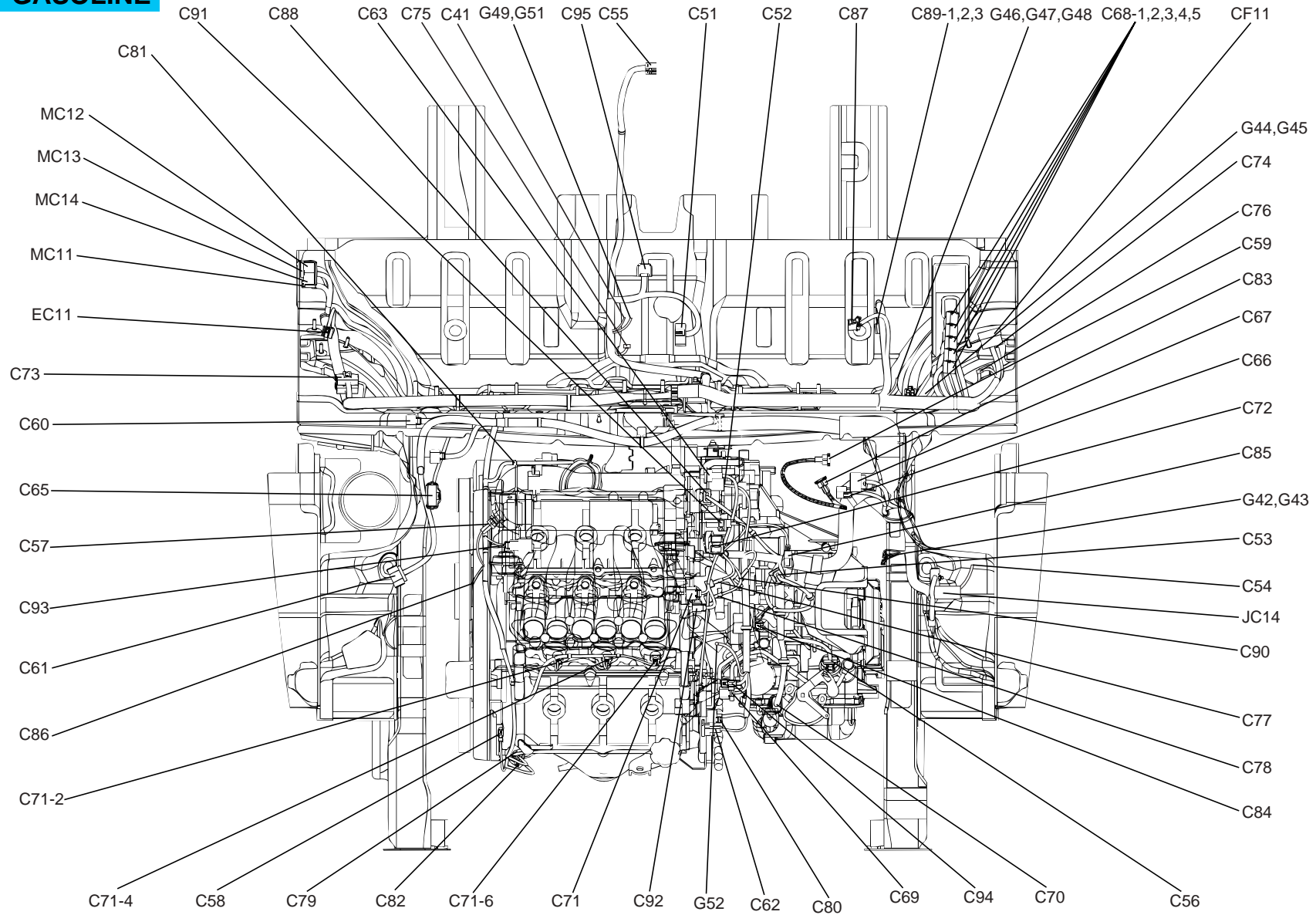

CONTROL HARNESS

CONTROL HARNESS (4)

HL-10

CONTROL HARNESS (2.7 GASOLINE)

C51	4WD ECM	C81	Oxygen Sensor #4 (EURO)
C52	Oxygen Sensor #1	C82	Oil Pressure Switch
C53	Mass Air flow Sensor	C83	Pressure Sensor
C54	Multipurpose Check Connector	C84	Pulse Generator "A"
C55	ATM Lever Switch	C85	Pulse Generator "B"
C56	ATM Solenoid Valve	C86	Power Steering Switch
C57	Air Temperature Sensor	C87	Stop Lamp Switch
C58	A/C Compressor	C88	Vehicle Speed Sensor
C59	Brake Fluid Level Sensor	C89-1	TCM
C60	Burglar Horn	C89-2	TCM
C61	Cruise Control Module	C89-3	TCM
C62	Crankshaft Position Sensor	C90	Camshaft Position Sensor
C63	Canister Purge Control Valve	C91	Throttle Position Sensor
C65	DRL Control Module	C92	Variable Intake Manifold Control Motor #2
C66	Windshield Defogger	C93	Variable Intake Manifold Control Motor #1
C67	Front Wiper Motor	C94	Engine Coolant Temperature Sensor & Sender
C68-1	ECM	C95	G-YAW Sensor
C68-2	ECM	CF11	Connection With FLOOR Harness
C68-3	ECM	EC11	Connection With ENGINE Harness RH
C68-4	ECM	MC11	Connection With MAIN Harness
C68-5	ECM	MC12	Connection With MAIN Harness
C69	Ignition Coil	MC13	Connection With MAIN Harness
C70	Transaxle Range Switch	MC14	Connection With MAIN Harness
C71	Connection With INJECTOR Harness #1, #3, #5	JC14	Connection With E/R JUNCTION BOX Harness
C71-2	Injector #2	G41	Ground
C71-4	Injector #4	G42	Ground
C71-6	Injector #6	G43	Ground
C72	Idle Speed Control Actuator	G44	Ground
C73	Joint Connector	G45	Ground
C74	Joint Connector	G46	Ground
C75	Joint Connector	G47	Ground
C76	Joint Connector	G48	Ground
C77	Knock Sensor #2	G49	Ground
C78	Knock Sensor #1	G51	Ground
C79	Oxygen Sensor #2	G52	Ground
C80	Oxygen Sensor #3 (EURO)		

CONTROL HARNESS

CONTROL HARNESS (5)

HL-11

DIESEL EURO-III

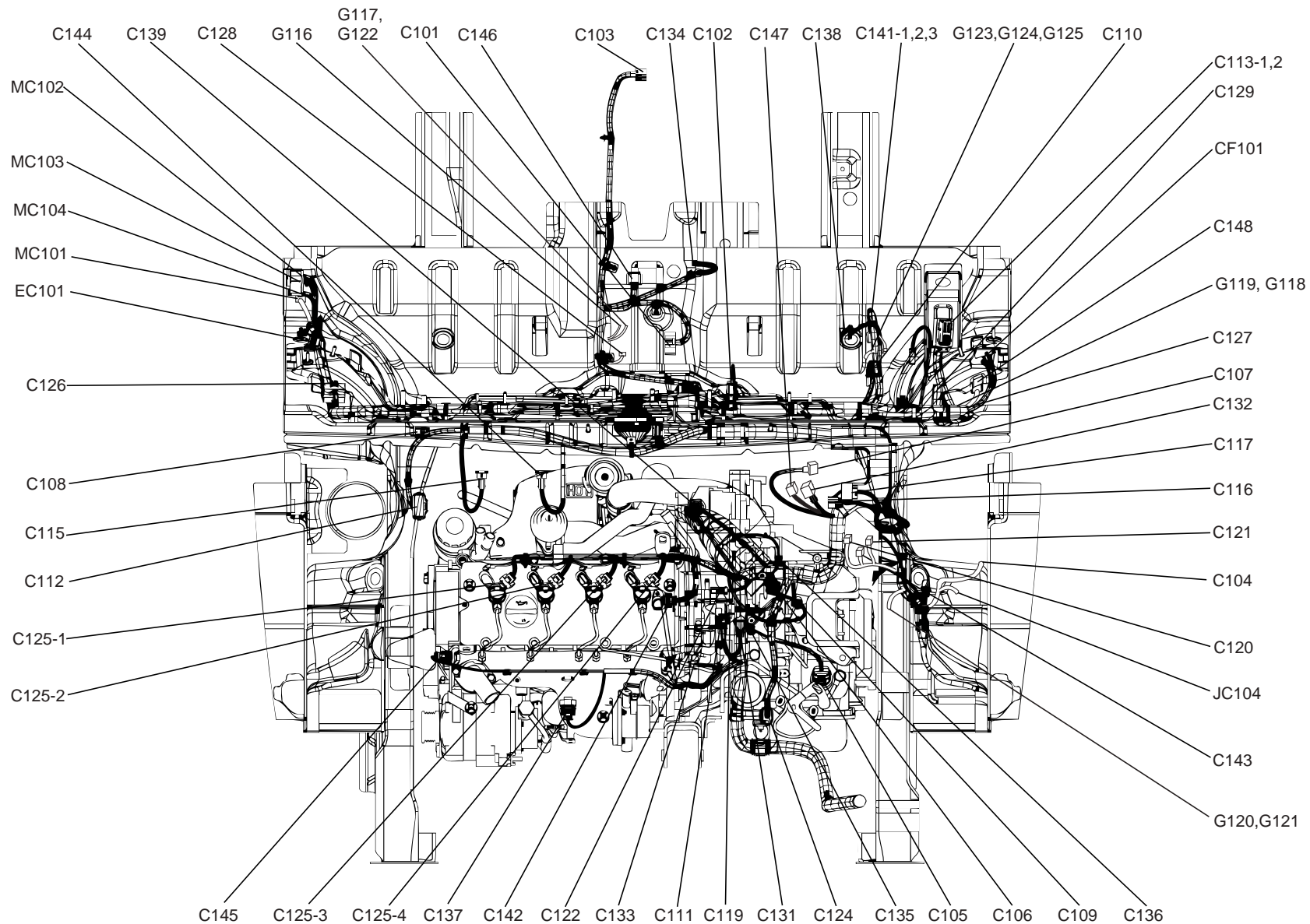

CONTROL HARNESS

CONTROL HARNESS (6)

HL-12

CONTROL HARNESS (DIESEL EURO-III)

C101	4WD ECM	C135	Pulse Generator 'A'
C102	Accelerator Pedal Sensor	C136	Pulse Generator 'B'
C103	ATM Lever Switch	C137	Rail Pressure Sensor
C104	Multipurpose Check Connector	C138	Stop Lamp Switch
C105	ATM Solenoid Valve	C139	Vehicle Speed Sensor
C106	Aif Flow Sensor	C141-1	TCM
C107	Brake Fluid Level Sensor	C141-2	TCM
C108	Burglar Horn	C141-3	TCM
C109	Back-Up Lamp Switch	C142	Camshaft Position Sensor
C110	Clutch Switch	C143	Thermo Switch
C111	Crankshaft Position Sensor	C144	Throttle Flap Actuator
C112	DRL Control Module	C145	Engine Coolant Temperature Sensor & Sender
C113-1	ECM	C146	G-YAW Sensor
C113-2	ECM	C147	Vacuum Switch
C115	EGR Actuator	C148	Joint Connector
C116	Windshield Defogger	C151	Glow Plug Relay
C117	Front Wiper Motor	C153	PTC Heater Relay #1
C119	Fuel Temperature Sensor	C154	PTC Heater Relay #2
C120	Fuel Filter Heater	C155	PTC Heater Relay #3
C121	Fuel Filter Warning Switch	C156	Fuel Filter Heater Relay
C122	Glow Plug	CF101	Connection With FLOOR Harness
C124	Transaxle Range Switch	EC101	Connection With ENGINE Harness RH
C125-1	Injector #1	MC101	Connection With MAIN Harness
C125-2	Injector #1	MC102	Connection With MAIN Harness
C125-3	Injector #1	MC103	Connection With MAIN Harness
C125-4	Injector #1	MC104	Connection With MAIN Harness
C126	Joint Connector	JC104	Connection With E/R JUNCTION BOX Harness
C127	Joint Connector	G116	Ground
C128	Joint Connector	G117	Ground
C129	Joint Connector	G118	Ground
C130	First Gear Switch	G119	Ground
C131	Oil Pressure Switch	G120	Ground
C132	Pressure Sensor	G121	Ground
C133	Rail Pressure Regulator	G122	Ground
C134	PTC Heater	G123	Ground
		G124	Ground
		G125	Ground

CONTROL HARNESS

CONTROL HARNESS (7)

HL-13

DIESEL EURO-IV

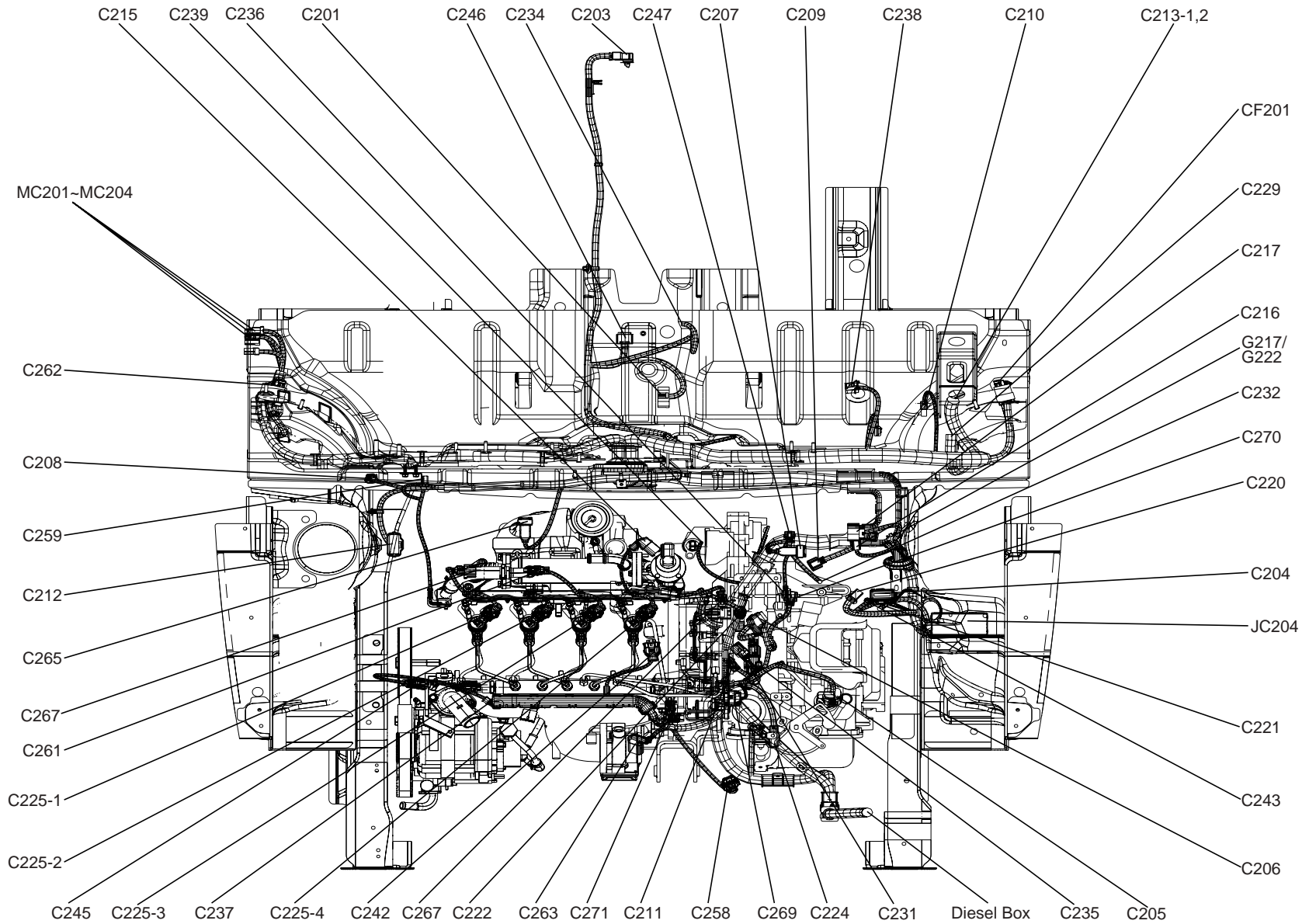

CONTROL HARNESS

CONTROL HARNESS (8)

HL-14

CONTROL HARNESS (DIESEL EURO-IV)

C201	4WD ECM	C241-1	TCM
C202	Accelerator Pedal Sensor	C241-2	TCM
C203	ATM Lever Switch	C241-3	TCM
C204	Multipurpose Check Connector	C242	Camshaft Position Sensor
C205	ATM Solenoid Valve	C243	Thermo Switch
C206	Aif Flow Sensor	C245	Engine Coolant Temperature Sensor & Sender
C207	Brake Fluid Level Sensor	C246	G-YAW Sensor
C208	Burglar Horn	C247	Vacuum Switch
C209	Back-Up Lamp Switch	C248	Joint Connector
C210	Clutch Switch	C251	Glow Plug Relay
C211	Crankshaft Position Sensor	C253	PTC Heater Relay #1
C212	DRL Control Module	C254	PTC Heater Relay #2
C213-1	ECM	C255	PTC Heater Relay #3
C213-2	ECM	C256	Fuel Filter Heater Relay
C215	EGR Actuator	C258	Boost Pressure Sensor
C216	Windshield Defogger	C259	Differential Pressure Sensor
C217	Front Wiper Motor	C261	Exhaust Gas Temperature Sensor #1
C219	Fuel Temperature Sensor	C262	Exhaust Gas Temperature Sensor #2
C220	Fuel Filter Heater	C263	Electrical Throttle Control Aactuator
C221	Fuel Filter Warning Switch	C265	VGT Actuator
C222	Glow Plug	C267	Fuel Metering Unit
C224	Transaxle Range Switch	C268	Lambda Sensor
C225-1	Injector #1	C269	Variable Swirl Control Actuator
C225-2	Injector #1	C270	Neutral Switch
C225-3	Injector #1	C271	Fuel Pressure Regulating Valve
C225-4	Injector #1	CF201	Connection With FLOOR Harness
C226	Joint Connector	EC201	Connection With ENGINE Harness RH
C227	Joint Connector	MC201	Connection With MAIN Harness
C228	Joint Connector	MC202	Connection With MAIN Harness
C231	Oil Pressure Switch	MC203	Connection With MAIN Harness
C232	Pressure Sensor	MC204	Connection With MAIN Harness
C234	PTC Heater	JC204	Connection With E/R JUNCTION BOX Harness
C235	Pulse Generator 'A'	G216	Ground
C236	Pulse Generator 'B'	G217	Ground
C237	Rail Pressure Sensor	G218	Ground
C238	Stop Lamp Switch	G220	Ground
C239	Vehicle Speed Sensor(A/T)	G221	Ground
C240	Vehicle Speed Sensor(M/T)	G222	Ground
		G223	Ground

AIR BAG HARNESS (1)

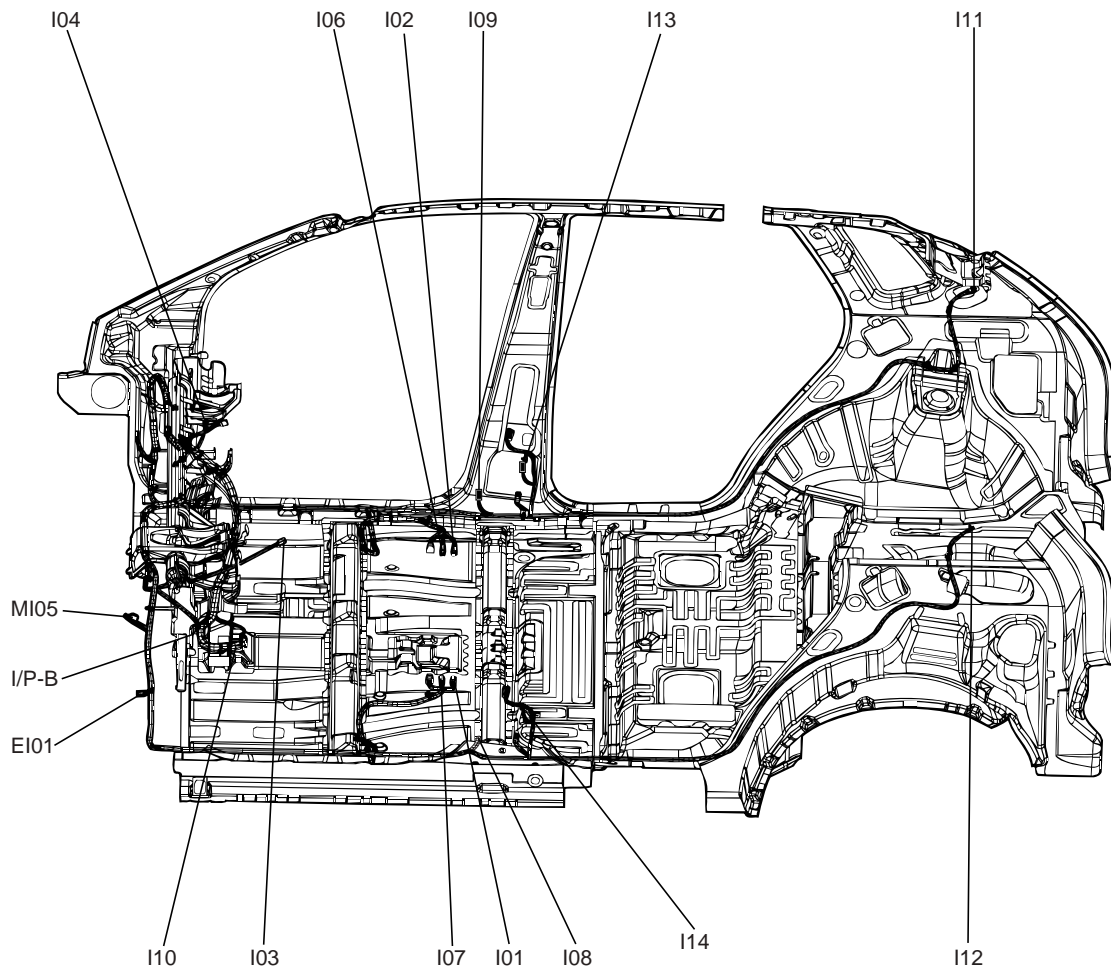

A/BAG HARNESS

- I01 Driver Side Air Bag
- I02 Passenger Side Air Bag
- I03 Multifunction Switch (Driver Air Bag)
- I04 Passenger Air Bag
- I06 Passenger Seat Buckle Switch
- I07 Driver Seat Buckle Switch
- I08 Driver Side Impact Sensor
- I09 Passenger Side Impact Sensor
- I10 SRS Control Module
- I11 Passenger Curtain Air Bag
- I12 Driver Curtain Air Bag
- I13 Passenger Seat Belt Pretensioner
- I14 Driver Seat Belt Pretensioner
- EI01 Connection With FRONT Harness LH
- I/P-B Connection With I/P JUNCTION BOX Harness (LHD)
- I/P-BR Connection With I/P JUNCTION BOX Harness (RHD)
- MI05 Connection With MAIN Harness
- G37 Ground

A/C HARNESS (1)

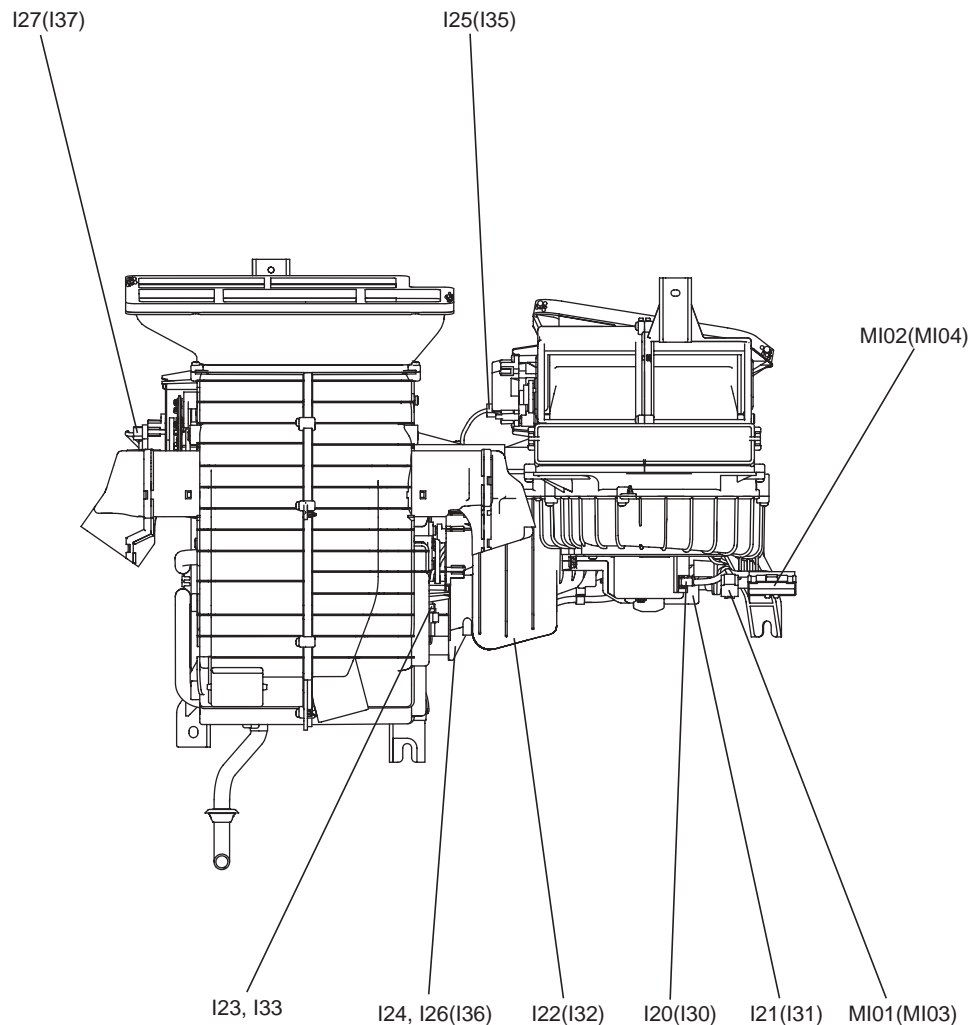

A/C HARNESS (AUTO)

- I20 Bower Motor
- I21 Bower Relay
- I22 Power Mosfet
- I23 Mix Actuator
- I24 Water Temperature Sensor
- I25 Intake Actuator
- I26 Evaporator Temperature Sensor
- I27 Mode Actuator
- MI01 Connection With MAIN Harness
- MI02 Connection With MAIN Harness

A/C HARNESS (MANUAL)

- I30 Bower Motor
- I31 Bower Relay
- I32 Power Mosfet
- I33 Mix Actuator
- I35 Intake Actuator
- I36 Evaporator Temperature Sensor
- I37 Mode Actuator
- MI02 Connection With MAIN Harness
- MI04 Connection With MAIN Harness

() : MANUAL A/C

DOOR HARNESS (1)

FRONT DOOR

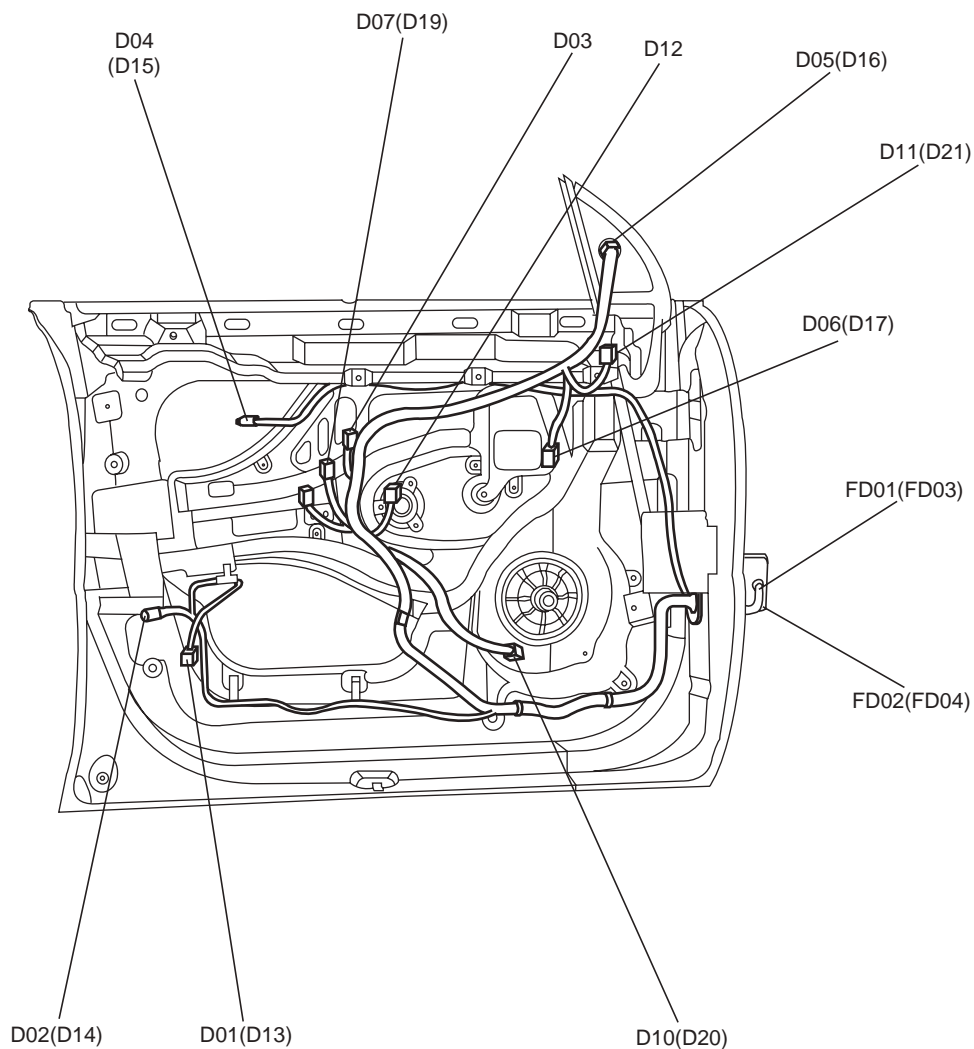

DRIVER DOOR HARNESS

- D01 Driver Door Lamp
- D02 Driver Door Lock Actuator (LHD)
- D02R Driver Door Lock Actuator (RHD)
- D03 Joint Connector
- D04 Driver Door Key Switch
- D05 Driver Power Outside Mirror Motor
- D06 Driver Power Window Motor
- D07 Driver Power Window Switch
- D10 Driver Door Speaker
- D11 Driver Tweeter Speaker
- D12 Power Outside Mirror Switch (LHD)
- D12R Power Outside Mirror Switch (RHD)
- FD01 Connection With FLOOR Harness
- FD02 Connection With FLOOR Harness

PASSENGER DOOR HARNESS

- D13 Passenger Door Lock Actuator (LHD)
- D14 Passenger Door Lock Actuator (RHD)
- D14R Passenger Door Key Switch
- D15 Passenger Power Outside Mirror Motor
- D16 Passengerr Power Window Motor
- D17 Passenger Power Window Switch
- D19 Passenger Door Speaker
- D20 Passenger Tweeter Speaker
- D21 Connection With FLOOR Harness
- FD03 Connection With FLOOR Harness
- FD04

(): PASSENGER

DOOR HARNESS

DOOR HARNESS (2)

HL-18

REAR DOOR

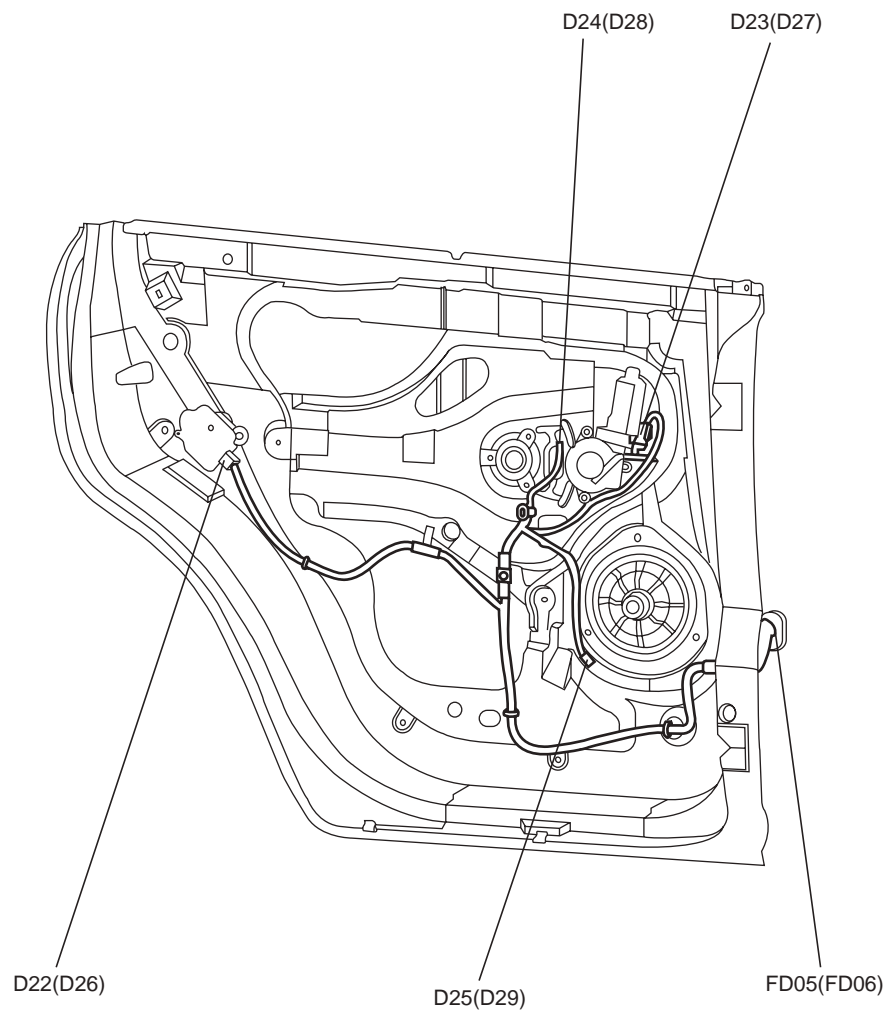

REAR DOOR HARNESS LH

- D22 Rear Door Lock Actuator LH
- D23 Rear Power Window Motor LH
- D24 Rear Power Window Switch LH
- D25 Rear Door Speaker LH
- FD05 Connection With FLOOR Harness

REAR DOOR HARNESS RH

- D26 Rear Door Lock Actuator RH
- D27 Rear Power Window Motor RH
- D28 Rear Power Window Switch RH
- D29 Rear Door Speaker RH
- FD06 Connection With FLOOR Harness

() : RIGHT

TAIL GATE HARNESS (1)

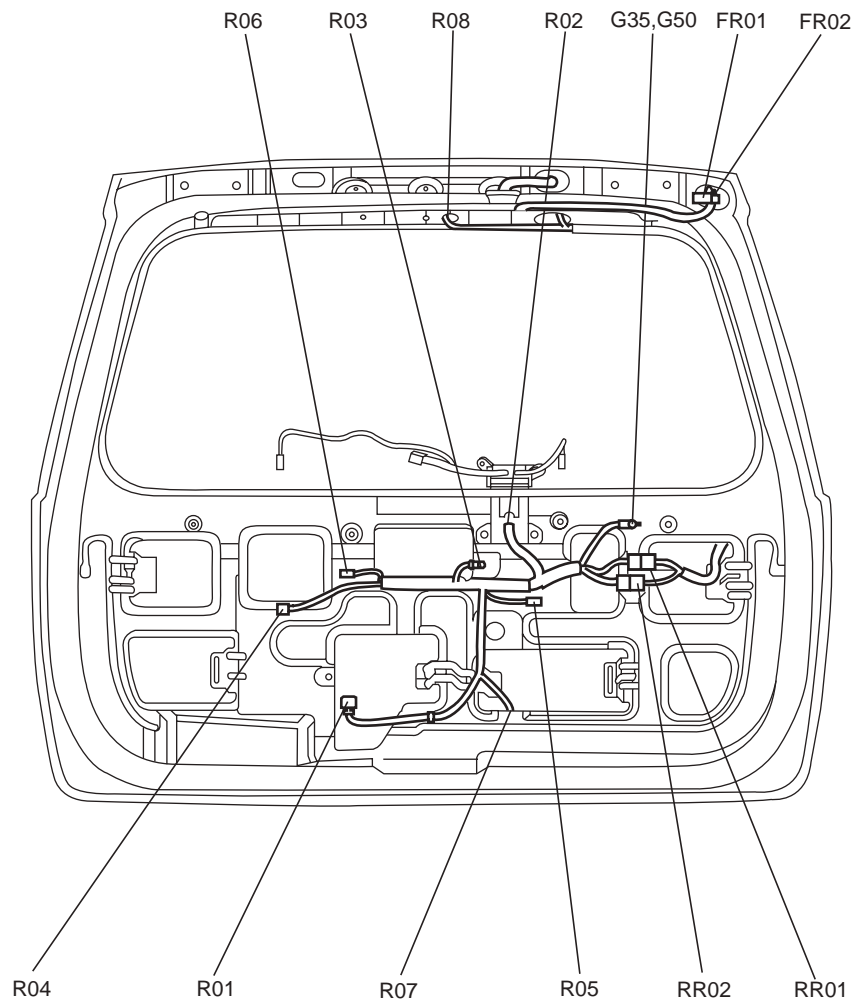

TAIL GATE HARNESS

- R01 Tail Gate Lock Actuator
- R02 Contact
- R03 Rear Window Switch
- R04 Tail Gate Key Switch
- R05 License Lamp LH
- R06 License Lamp RH
- R07 Tail Gate Switch
- RR01 Connection With TAIL GATE EXT. Harness
- RR02 Connection With TAIL GATE EXT. Harness
- G35 Ground
- G50 Ground

TAIL GATE EXT. HARNESS

- R08 High Mounted Stop Lamp
- FR01 Connection With FLOOR Harness
- FR02 Connection With FLOOR Harness
- RR01 Connection With TAIL GATE Harness
- RR02 Connection With TAIL GATE Harness